

DEVELOPMENT OF AIR DATA COMPUTATION FUNCTION OF A COMBINED AIR  
DATA AND AOA COMPUTER

A THESIS SUBMITTED TO  
THE GRADUATE SCHOOL OF NATURAL AND APPLIED SCIENCES OF ÇANKAYA  
UNIVERSITY

BY

RAFET ILĞİN

IN PARTIAL FULLFILLMENT OF THE REQUIREMENTS  
FOR  
THE DEGREE OF MASTER OF SCIENCE  
IN  
ELECTRONICS AND COMMUNICATIONS ENGINEERING

SEPTEMBER, 2011

Title of the Thesis: **Development of Air Data Computation Function of a Combined Air Data and AOA Computer**

Submitted By: **Rafet ILĞİN**

Approval of the Graduate School of Natural and Applied Sciences

  
Prof. Dr. Taner ALTUNOK

Director

I certify that this thesis satisfies all the requirements as a thesis for the degree of Master of Science.

  
Prof. Dr. Celal Zaim ÇİL

Head of Department

This is to certify that we have read this thesis and that in our opinion it is fully adequate, in scope and quality, as a thesis for the degree of Master of Science.

  
Prof. Dr. Celal Zaim ÇİL

Supervisor

Examination Date : 16.09.2011

Examining Committee Members:

Prof. Dr. Celal Zaim ÇİL

(Çankaya Univ.)

Assistant Prof. Dr. Klaus SCHMIDT

(Çankaya Univ.)

Assistant Prof. Dr. Altan ÖZKİL

(Atılım Univ.)

## STATEMENT OF NON-PLAGIARISM

I hereby declare that all information in this document has been obtained and presented in accordance with academic rules and ethical conduct. I also declare that, as required by these rules and conduct, I have fully cited and referenced all material and results that are not original to this work.

Name, Last Name : Rafet ILĖIN

Signature : 

Date : 23.12.2011

## **ACKNOWLEDGEMENTS**

The author wishes to express his deepest gratitude to his supervisor Prof. Dr. Celal Zaim ÇİL for his guidance, advice, criticism, encouragements and insight throughout the research.

The author would also like to thank Mehmet Mustafa KARABULUT for his suggestions and comments

## **ABSTRACT**

### **DEVELOPMENT OF AIR DATA COMPUTATION FUNCTION OF A COMBINED AIR DATA AND AOA COMPUTER**

**ILĞİN, Rafet**

**M.Sc., Department of Electronics and Communication Engineering**

**Supervisor: Prof. Dr. Celal Zaim ÇİL**

**September 2011, 51 Pages**

In this thesis, Air Data Computer part of a Combined Air Data System (CADS) and the simulator environment to test the developed CADS are developed on standard personal computers. Normally, a CADS system on an aircraft is composed of two separate equipments, the Air Data Computer (ADC) and the Angle of Attack (AOA) system. Therefore the developed CADS system combines both functionalities in an integral manner on a card. This approach not only reduces the volume but the total cost of the CADS system as well.

**Keywords:** Avionic, System Integration, Flight Simulation, Software, Air Data Calculation, Sensor Simulation

## ÖZ

### TÜMLEŞİK HAVA VERİ VE HÜCUM AÇISI BİLGİSAYARI HAVA VERİ FONKSİYONLARI HESAPLAMALARI GELİŞTİRMELERİ

İLGİN, Rafet

Yüksek Lisans, Elektronik ve Haberleşme Mühendisliği Anabilim Dalı  
Tez Yöneticisi: Prof. Dr. Celal Zaim ÇİL

Eylül 2011, 51 Sayfa

Bu tez çalışmasında, standart bir bilgisayar üzerinde gerçek arayüzler kullanılmadan Tümlleşik Hava Veri Sistemi' nin Hava Veri Bilgisayarı ve bunu test edecek simulator ortamının tasarımı yapılmıştır. Normalde, hava araçlarında bu sistemin görevini yerine getirebilmek için iki adet farklı ekipman kullanılmaktadır. Bu ekipmanlardan bir tanesi Hava Veri Bilgisayarı, bir diğeri de Hücum Açısı Bilgisayarı'dır. Tasarlanan tümlleşik sistem ise iki ekipmanı bir kart üzerinde gerçekleştirmektedir. Bu nedenle, tasarlanan tümlleşik sistem hacimden ve maliyetten tasarruf sağlamaktadır.

**Anahtar Kelimeler:** Aviyonik, Sistem Entegrasyonu, Uçuş Simülasyonu, Yazılım, Hava Veri Hesaplamaları, Sensör Simülasyonu

## TABLE OF CONTENTS

STATEMENT OF NON-PLAGIARISM .....	iii
ACKNOWLEDGEMENTS .....	iv
ABSTRACT .....	v
ÖZ .....	vi
TABLE OF CONTENTS .....	vii
LIST OF TABLES .....	ix
LIST OF FIGURES .....	x
LIST OF ABBREVIATIONS.....	xi
CHAPTERS:	
1. INTRODUCTION .....	1
2. THE FUNCTION OF THE ADC IN THE COMBINED SYSTEM .....	5
2.1. Pressure Altitude .....	12
2.1.1. Derivation of pressure altitude.....	12
2.2. Baro Corrected Altitude .....	14
2.3. Indicated Airspeed: .....	15
2.4. True Airspeed .....	15
2.4.1. Derivation of true airspeed.....	15
2.5. Mach Number.....	17
2.5.1. Derivation of mach number.....	17
2.5.1.1. Derivation for subsonic speeds:.....	17
2.5.1.2. Derivation for supersonic speeds: .....	20
2.6. Temperature Parameters .....	21
2.6.1. Derivation of SAT .....	22
3. DETAILED DESCRIPTION OF THE SYSTEM DEVELOPED.....	24
3.1. Properties of the SC.....	25

4. CADs VERSUS REAL EQUIPMENT.....	28
4.1. Real ADC .....	28
4.1.1. Functionality and performance standards.....	30
4.1.2. Environmental standards.....	32
4.1.3. Communication standards.....	33
4.1.4. Software standards .....	34
5. GENERAL VIEW OF THE SC SYSTEM SOFTWARE DESIGN .....	37
6. CONFIGURATION ITEMS .....	40
6.1. Hardware Configuration Items:.....	40
6.2. The Software Configuration Items: .....	41
7. TEST AND VERIFICATION OF THE SYSTEM DEVELOPED .....	42
8. CONCLUSION .....	50
REFERENCES .....	R1
APPENDICES:	
A. MICROSOFT FSX .....	A1
B. SOURCE CODE OF SIMULATION SYSTEM .....	A2
C. CURRICULUM VITAE .....	A14



## LIST OF TABLES

### TABLES

<b>Table 1</b> Aircraft Environment Data .....	26
<b>Table 2</b> Aircraft Landing Gear Data.....	26
<b>Table 3</b> Some of the Criteria Included in DO 160 [5] .....	32
<b>Table 4</b> DO 178B Software Levels .....	36
<b>Table 5</b> List of the Inputs of the CADs .....	49

## LIST OF FIGURES

### FIGURES

<b>Figure 1</b> ADC in Avionics Architecture .....	7
<b>Figure 2</b> Pitot and Static Ports [6] .....	9
<b>Figure 3</b> Pitot and Static Ports Installation [7] .....	10
<b>Figure 4</b> TAT Probe Installation on the A/C [8] .....	11
<b>Figure 5</b> Pressure Measurement System [14].....	17
<b>Figure 6</b> Demonstration of the System Architecture.....	24
<b>Figure 7</b> GUI of the SC.....	27
<b>Figure 8</b> An example ADC Internal Architecture [16] .....	28
<b>Figure 9</b> Typical Architecture of ADC Given by Manufacturer [16] .....	29
<b>Figure 10</b> ARINC 429 Message Structure [18].....	33
<b>Figure 11</b> The SWCI of the Developed System .....	41
<b>Figure 12</b> CADS System Verification of the System Developed .....	43
<b>Figure 13</b> TAS Calculated By CADS vs. FSX .....	44
<b>Figure 14</b> IAS Calculated By CADS vs. FSX .....	45
<b>Figure 15</b> Mach Number Calculated By CADS vs. FSX.....	46
<b>Figure 16</b> Pressure Altitude Calculated By CADS vs. FSX .....	47
<b>Figure 17</b> TAT Calculated By CADS vs. FSX .....	48

## **LIST OF ABBREVIATIONS**

**ADC** - air data computer

**ARINC** - aeronautical radio incorporated

**AS** - aerospace standard

**A/C** - aircraft

**CADS** - combined air data system

**CAS** - calibrated air speed

**C<sub>p</sub>** - constant pressure

**C<sub>v</sub>** - constant volume

**DAL** - design assurance level

**EUROCAE** - european organization for civil aviation equipment

**FAA** - federal aviation agency

**FAR** - federal aviation regulations

**FSX** - flight simulator x

**ft** - feet

**GHz** - giga hertz

**HMI** - human machine interface

**HWCI** - hardware configuration item

**IAS** - indicated airspeed

**IFF** - identification friend or foe

**IMA** - integrated modular avionics

**INS** - inertial navigation system

**kbps** – kilo bits per second

**LCD** – liquid crystal display

**LRU** - line replaceable unit

**m** - meters

**NATO** - north atlantic treaty organization

**OS** - operating system

**PC** - personal computer

**RAM** – random access memory

**RF** – radio frequency

**RTCA** - radio technical commission for aeronautics

**SAE** - society of automotive engineers

**SAP** - static air pressure

**SC** - simulation computer

**SDK** - software Development Kit

**SSA** - system safety assessments

**SSEC** – static source error correction

**SSR** - second surveillance radar

**SWCI** - software configuration items

**TACAN** - tactical air navigation

**TAP** - total air pressure

**TAS** - true airspeed

**TAT** - total air temperature

**TSO** - technical standard order

**V** - volume

**VHF** - very high frequency

# **CHAPTER 1**

## **INTRODUCTION**

The term “aviation” arose in 18th century from the combination of the two words : avionics and electronics. It quickly became one of the most frequently used words in the aviation sector in the 20 century.. This revealed the amount of the scientific research and technology development which have resulted in a huge growth in avionics during the next years. Today, avionics systems are the most important components of manned and unmanned air platforms.

In early times of the first quarter of the 20'th century it was very difficult to make air travel in foggy, dark, rainy or snowy weather. These weather conditions were causing fatal air crashes. Ceasing of military operations because of harsh weather conditions was the main concern of the armies. Thus, the investigation about the basic information for a safe flight in any weather conditions has started. Altitude was the first parameter investigated. Altimeter accuracy was crucial for a pilot to avoid crashes that occur mostly in landing and taking off. In the foggy, cloudy or dark weather conditions, it was sometimes getting nearly impossible for a pilot to decide about the attitude of the aircraft with respect to a reference system, such as horizon. Therefore, the subject that was researched heavily next was the natural horizon. Voice communication was the next important subject, important for a safe flight. The communication between the pilot and the air control station was very crucial.

After resolving these basic issues for a safe flight the avionics sector succeeded to make a major development. The first application of electronics in aviation occurred in the first quarter of the 20'th century. Non-directional beacons, ground-based

surveillance radar, and the single-axis autopilot were the first electronic aids introduced. Next, in the second quarter of the 20<sup>th</sup> century gyro compass, attitude and heading reference systems, airborne intercept radar, early electronic warfare systems, VHF communications, identification friend or foe (IFF), military long-range precision radio navigation aids and the two-axes autopilot were among the most fundamental applications developed. The third quarter of the 20<sup>th</sup> century is considered the golden age in avionic applications' development. Terrain-following radar, Mission Computers (MCs) and inertial navigation systems (INSs), integrated electronic warfare systems, tactical air navigation (TACAN), Doppler radar were the innovations brought to the flight sector in the third quarter of 20<sup>th</sup> century. [1]

The flying platforms developed initially include mostly avionics of point-to-point architectures. In this kind of architecture all of the data communications between the control unit or indicator and the sensor were made between the destination and the source equipment. There was not any network structure. Point-to-point architectures had major disadvantages like power consumption, space consumption, cabling and weight. Moreover, they were difficult to modify. Another disadvantage of this architecture was that each system on the flying platform has its dedicated subsystems, such as power supplies, control panels and displays etc. These dedicated subsystems, displays and control panels were electromechanical; therefore they were generally not very reliable at that time and were rather frequently breaking down. Also they were mostly analog devices, and therefore, the accuracy and stability of the computed data from them werenot satisfactory as they are in today's digital systems.

After the development of digital computing devices avionics architectures became distributed. This development has eliminated complex error detection methods which were used in the analog architectures. Digital avionics architecture became easy to maintain and handle. However, after became digitized the improvement in

the avionic architectures did not stop but continued. For example, in the distributed digital avionics architecture, each black box used to have its own computation unit. There used to be dedicated displays as it was in the analog architecture. Later on, the displays changed from electromechanical devices to multifunctional and multicolored electronic ones. Furthermore network structures like the “data bus” was introduced to be used with distributed digital avionics. “Aeronautical Radio Incorporated (ARINC) 429” bus, for instance, was introduced at these times. Flexibility in signal transmission and reduction in wiring, which caused reduction in power consumption, weight, harness and cost are the results of the network implementation in avionics architecture.

The next generation in avionics architecture was federated digital architecture. This type of architecture entailed the need for a bus controller. This development yielded a safer and more upgradeable architecture. With these developments, military standards for data bus applications in avionic architectures also came into world. The most well-known military standard for a data bus on flying platforms is MIL-STD-1553 today. MIL-STD-1553 data bus was applied across all North Atlantic Treaty Organization (NATO) member countries. Dedicated 1553B-interfaced equipment line replaceable units (LRUs) and subsystems were generally used by federated architectures. MIL-STD-1553 provided the federated architectures with a more reliable and robust structure when compared with the previous architectures.

New world conditions yielded new types of aircraft such as unmanned, small platforms etc. Research and development of Integrated Modular Avionics (IMA) has been originated from these requirements. The size of components and the size of avionic equipments should become smaller. IMA aims to replace more than one equipment into one black box. These brought power saving, ruggedness, harness reduction, reliability, weight reduction, and most importantly, a much more flexible architecture.



The purpose of this thesis is to design and develop the air data computer part of a CADC, which is the result of IMA in aircraft (A/C). ADC is one of the necessary equipments in the avionics architecture. The basic and necessary flight parameters are calculated by the ADC. The calculated parameters are used in a lot of systems such as engine control units, cockpit displays etc.

The ADC provides accurate information about pressure altitude, vertical speed (altitude rate), airspeed, and air temperature. To calculate the parameters listed above, the ADC has three inputs. These are static air pressure, total air pressure and total air temperature. The source of these parameters is the static port, the pitot tube and the total air temperature. The information calculated by the ADC is essential for the pilot to fly the aircraft safely, and is also required by a lot of number of key subsystems in the aircraft such as landing gear system, air conditioning system, transponder, inertial navigation system etc.

In this thesis, research of ADC functionality and derivation of required parameters for this functionality of a CADC is performed. Then, an emulator/simulator environment (the Simulation Computer-SC) for testing the CADC System is designed and developed to provide the necessary parameters from the "sensors" to the CADC in accordance with a flight scenario using a generic flying platform that can fly over a terrain and subject to weather conditions as well. The SC is used to test the developed CADC software and verify if it confirms the requirements for the CADC. The real sensors are not used on the emulation, as it is impossible since the system is not flying. Instead, the data is calculated and produced in accordance with a flight scenario on a generic platform, as if it was provided by the real sensors based on a certain flight scenario. The human machine interface (HMI) is generated on the personal computer (PC) screen in order to mimic the displays for a real CADC drives on an aircraft.

## **CHAPTER 2**

### **THE FUNCTION OF THE ADC IN THE COMBINED SYSTEM**

The ADC is one of the necessary equipment in avionics architecture. There are some mandatory standards for this equipment to be installed on aircraft. These are basically:

- Federal Aviation Agency (FAA) Technical Standard Order (TSO) C106 for equipment's functionality [2]

TSO C106 is a minimum performance standard. This TSO prescribes the minimum performance standard that air data computers must meet in order to be identified with the applicable TSO marking which defines the ADC equipment as "safety of flight or not". New models of air data computers that are to be so identified and that are manufactured on or after the date of this TSO must meet the standard set forth in the Society Of Automotive Engineers (SAE), Aerospace Standard (AS) 8002, "Air Data Computer - Minimum Performance Standard," dated October 30, 1981.

SAE 8002 defines the performance of the designed equipment. It also specifies the mandatory and optional parameters which will be given by the designed equipment and their accuracies.

- FAA TSO C88a for equipment's functionality [3]

TSO C88a is a minimum performance standard. This TSO prescribes the minimum performance standard that automatic pressure altitude reporting code generating equipment must meet in order to be identified with the applicable TSO marking.

This TSO has been prepared in accordance with the procedural rules set forth in Subpart of the Federal Aviation Regulations (FAR) Part 21. New models of automatic pressure altitude reporting code generating equipment that are to be so identified and that are manufactured on or after the date of this TSO must meet the standards set forth in the SAE AS 8003, "Minimum Performance Standard for Automatic Pressure Altitude Reporting Code Generating Equipment," dated July 1974.

- Radio Technical Commission For Aeronautics (RTCA)/DO-178B for equipment's software

DO-178B, Software Considerations in Airborne Systems and Equipment Certification is the title of a document published by RTCA. Development was a joint effort with European Organization for Civil Aviation Equipment (EUROCAE) who published the document as ED-12B. When specified by the TSO for which certification is sought, the FAA applies DO-178B as the document it uses for guidance to determine if the software will perform reliably in an airborne environment. DO-178B has levels like Level A, Level B and these levels are determined according to safety assessments made for related equipment. In the safety assessment workout, each output parameter of the equipment is investigated. The criticality of loss of each parameter (i.e. if this parameter has been lost, then the effect of this situation results in a catastrophic failure) determines the level of software. [4]

- RTCA/DO-160 for equipment's environmental stamina

DO-160 is "Environmental Conditions and Test Procedures for Airborne Equipment" standard and it is for environmental test of avionics hardware published by RTCA, Incorporated.

This document outlines a set of minimal standard environmental test conditions (categories) and corresponding test procedures for airborne equipment. The purpose of these tests is to provide a controlled (laboratory) means of assuring the performance characteristics of airborne equipment in environmental conditions similar of those which may be encountered in airborne operation of the equipment. The standard environmental test conditions and test procedures contained within the standard may be used in conjunction with applicable equipment performance standards, as a minimum specification under environmental conditions, which can ensure an adequate degree of confidence in performance during use aboard an air vehicle. [5]

The basic and necessary flight parameters are calculated by the ADC. The calculated parameters are used in a lot of systems such as engine control units, cockpit displays etc. The relation between ADC and the peripheral systems are given in Figure 1.

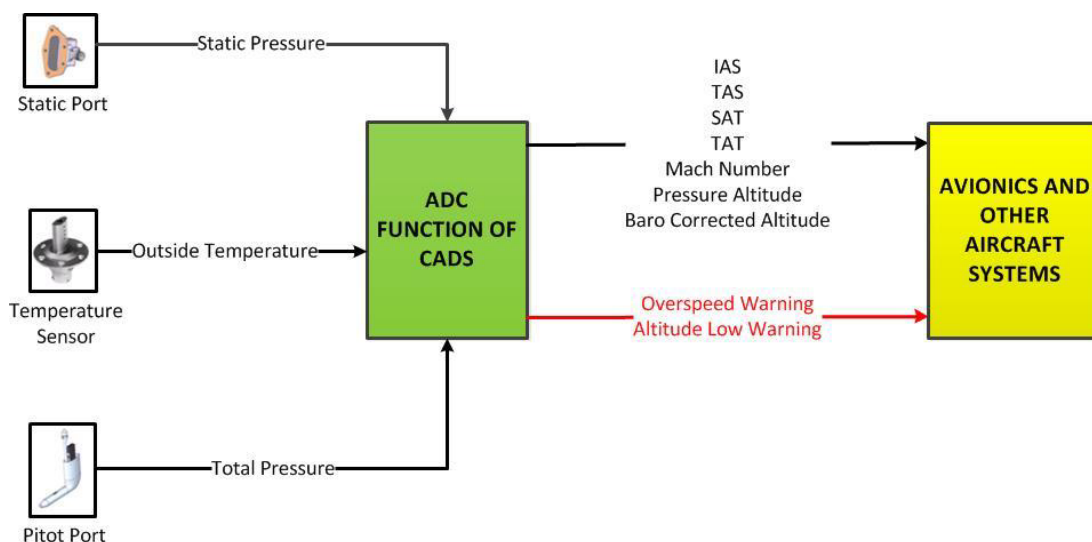

**Figure 1 ADC in Avionics Architecture**

There are three (3) basic parameters calculated by the ADC, which are:

- Altitude
- Airspeed
- Air Temperature.

Altitude is basically the height above the sea level. Airspeed is the speed of the A/C with respect to air surrounding it. Air temperature is the temperature of the air surrounding the A/C.

For these three parameters to be calculated, the ADC needs the following three (3) inputs:

- Static Air Pressure
- Total Air Pressure
- Total Air Temperature

The static air pressure (SAP) is the pressure of the air in which the A/C is cruising. Or the static pressure can be defined the static pressure as the atmosphere weight over a particular area in a given location. The higher the altitude, the less atmosphere above it, which means the lower the measured pressure. At sea level, the static air pressure raises the mercury in a barometer 29.92 inches. However, at 18,000 feet above sea level the pressure is only half as great-raising the mercury only 15 inches. In this way, static pressure measurements can give an indication of altitude.

The total air pressure (TAP) is the pressure of the air towards which the aircraft is cruising. The effect of aircraft's relative motion with respect to surrounding air is included in the TAP.

The total air temperature (TAT) is the temperature of the air surrounding the A/C. Sensed TAT includes the friction between the A/C and the air surrounding it.

The SAP is sensed via two parallel connected static ports per requester equipment in order to make an average calculation and to obtain a reliable system. Static ports are installed such that effect of the relative motion of the A/C with respect to air mass is excluded. Generally, these ports are installed on the side surfaces of the A/C.

The TAP is sensed via one pitot port per requester equipment. As can be seen from Figure 2, pitot ports are installed such that effect of the relative motion of the A/C with respect to air mass is included. Generally, these ports are installed on the front surfaces of the A/C, an example installation can be observed from Figure 3. [6]

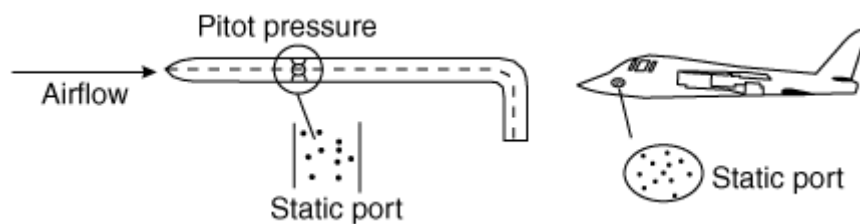

Figure 2 Pitot and Static Ports [6]

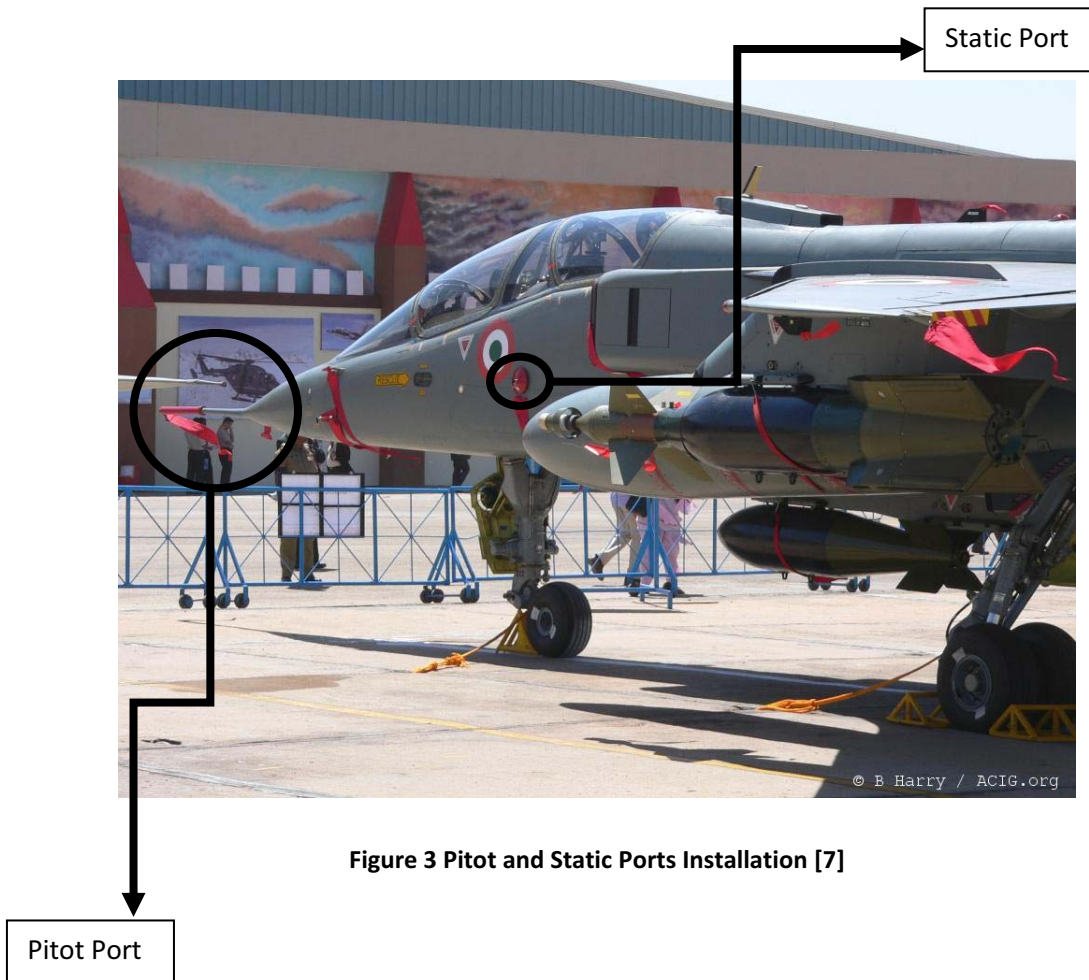
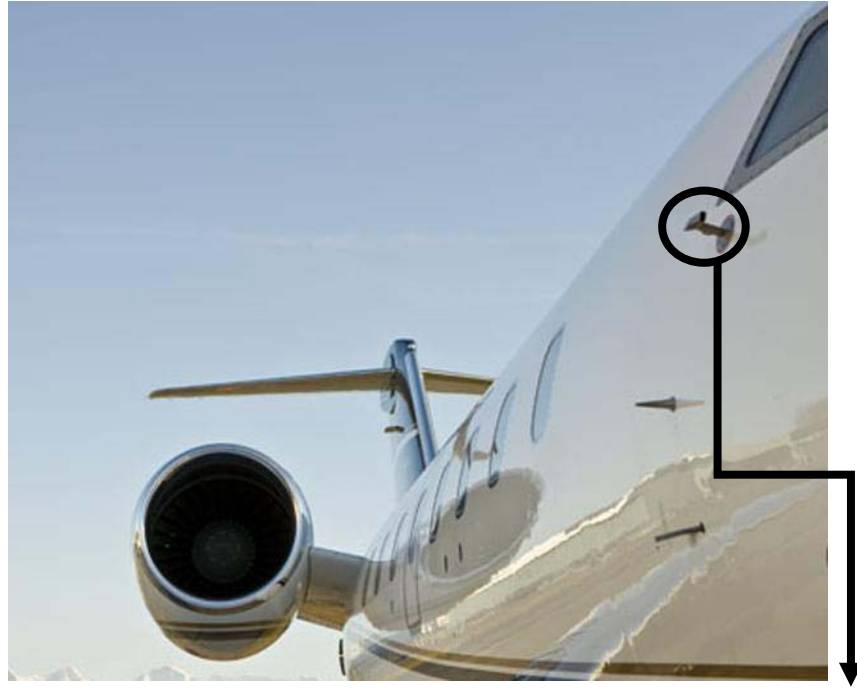

Figure 3 Pitot and Static Ports Installation [7]

The TAT probes are installed such that the temperature of surrounding air mass is sensed excluding the effect of propeller, if present. Figure 4 shows a typical TAT probe installation on an business jet A/C.



**Figure 4 TAT Probe Installation on the A/C [8]**

TAT Probe

When the ADC gets the accurate parameters listed above, it becomes ready to calculate the required parameters. These are:



## 2.1. Pressure Altitude

The pressure altitude is the height above the sea level. It is determined by measuring the atmospheric pressure.

$$h = \frac{(29.92126^{0.190255} - P_s^{0.190255})}{0.000013125214} \quad (2.1)$$

$h$  is the pressure altitude in feet,  $P_s$  is the static pressure in inches Hg sensed by static ports.

This formula is for low altitude, which is defined as  $h < 36,089$  feet (ft),  $P_s > 6.6832426$  inches Hg [9]. When pressure altitude falls below 100 feet altitude low warning will be generated.

### 2.1.1. Derivation of pressure altitude

In hydrostatic equilibrium, the change in pressure over an infinitesimal change in altitude must oppose the gravitational force on the air in that infinitesimal layer, that is

$$\frac{dP}{dz} == -\rho g \quad (2.2)$$

$P$  is pressure,  $z$  is altitude,  $\rho$  is air density, and  $g$  is the gravitational acceleration. In this equation and the equations below, double equal mark is used since the ideal environment assumption has been made. Ideal environment means the air is composed of nearly 78 % Nitrogen, about 21 % Oxygen and about 1 % of all other gases, such as Ozone, Neon, Carbon Dioxide to name a few.

The ideal gas law states

$$P == \rho RT \quad (2.3)$$

$R$  is the gas constant for air and  $T$  is the temperature.

Combining these equations,  $\rho$  can be eliminated:

$$\frac{dP}{dz} = -\left(\frac{g}{RT}\right)P \quad (2.4)$$

For constant  $T$  and  $g$ , this is a first order linear differential equation, the solution is obtained as

$$z = -\frac{RT}{g} \log \left[ \frac{P}{P_0} \right] \quad (2.5)$$

This equation is known as the hypsometric equation. It relates the pressure ratio to altitude under the assumptions of constant temperature and gravity.

The hypsometric equation is not very satisfactory because it assumes zero lapse-rate. It is mentioned here because it is often cited in the literature. It cannot be used for altitude determination unless the approximation of constant temperature is an acceptable one.

To get a better relation, the temperature must be taken as a variable. In general this leads to a nonlinear differential equation, but in the specific case of a linear change of temperature with altitude that is with a constant lapse rate the equation is tractable. Starting with

$$\frac{dP}{dz} [z] = -\frac{1}{R} \left( \frac{g[z]}{T[z]} \right) P [z] \quad (2.6)$$

The solution can be found by integration, that is

$$P [z] = P_0 \text{Exp} \left[ -\frac{1}{R} \left( \int_0^z \frac{g[\xi]}{T[\xi]} d\xi \right) \right] \quad (2.7)$$

$\xi$  is just a dummy variable for the integration.

Assuming  $g$  is constant with respect to altitude and introducing the linearized temperature profile via the lapse rate, the integral becomes

$$g \int_0^z \frac{d\xi}{T_0 + L\xi} = \frac{g}{L} (\log[T_0 + Lz] - \log[T_0]) \quad (2.8)$$

$L$  is the lapse rate.

Substituting this into the expression for  $P[z]$  (2.7) and solving for  $z$  gives

$$z = \frac{T_0}{L} \left( \left( \frac{P}{P_0} \right)^{-\frac{LR}{g}} - 1 \right) \quad (2.9)$$

$P_0$  is pressure at zero altitude (29.92 in Hg),  $L$  is lapse rate ( $-6.5 \times 10^{-3}$  K/m),  $R$  is gas constant for air (287.053 J/(kg\*K)),  $g$  is acceleration due to gravity ( $9.80665$  m/s<sup>2</sup>), and  $T_0$  is temperature at zero altitude (288.15 K).

This is the final, simplified, expression for altitude in terms of atmospheric pressure.  $L$  near the ground is a negative number should be remembered when using this expression. [10]

## 2.2. Baro Corrected Altitude

The baro corrected altitude is the height above a reference level which is entered by pilot's control panel. Pressure altitude assumes that the aircraft is on the sea level. In real life, it is not always true and therefore the pilot enters the  $P_s$  for the airway that he is about to take-off. In other words, baro corrected altitude is determined with respect to the reference level by measuring the atmospheric pressure.

Baro corrected altitude is calculated for the low altitude condition, which is defined as  $h < 36,089$  ft,  $P_s > 6.6832426$  inches Hg:

$$h = \frac{(Baro\ Correction^{0.190255} - P_s^{0.190255})}{0.000013125214} \quad (2.10)$$

$h$  is the pressure altitude in feet,  $P_s$  is the static pressure in inches Hg sensed by static ports, and baro correction is the reference value entered from pilots control panel.

### 2.3. Indicated Airspeed (IAS)

The IAS is defined as the speed of the aircraft with respect to air surrounding it. It is the function of total pressure and static pressure only:

$$IAS = 1479.1026 \sqrt{\left(\frac{P_t - P_s}{29.92126} + 1\right)^{\frac{2}{7}} - 1} \quad (2.11)$$

$P_t$  is the total pressure in inches Hg sensed from pitot port, and  $P_s$  is the Static pressure in inches Hg sensed from Static port. [9] When the IAS exceeds 350 knots, overspeed warning will be generated.

### 2.4. True Airspeed (TAS)

The TAS is defined as the speed of the aircraft relative to air surrounding it including the temperature effects, and it is calculated by [11]

$$TAS = a_{sl} \sqrt{\frac{5T}{T_{sl}} \times \left[\left(\frac{q_c}{P_s} + 1\right)^{\frac{2}{7}} - 1\right]} \quad (2.12)$$

$q_c$  is impact pressure,  $a_{sl}$  is the standard speed of sound at 15 °C (661.47 knots),  $T$  is the static air temperature in Kelvin,  $T_{sl}$  is the standard sea level temperature (288.15 K) [9].

#### 2.4.1. Derivation of true airspeed

The computation of the temperature of the free airstream,  $T_{sl}$ , enables the local speed of sound,  $A$ , to be established as

$$A = \sqrt{\gamma R_a T_{sl}} \quad (2.13)$$

$\gamma$  is the heat capacity ratio or adiabatic index or ratio of specific heats, the ratio of the heat capacity at constant pressure ( $C_p$ ) to heat capacity at constant volume ( $C_v$ ). It is sometimes also known as the isentropic expansion factor and is denoted by  $\gamma$  and its value is 1.4 for air.

Note, in thermodynamics, an adiabatic process is a thermodynamic process in which the net heat transfer to or from the working fluid is zero. [12]

$R_a$  is gas constant for unit mass of dry air and its value is 287.0529 Joules/°K/kg.

$M$  is the Mach number.

$$V_t = M \times A = M \sqrt{\gamma R_a T_{sl}} \quad (2.14)$$

$T_{sl}$  is the static air temperature at the sea level. The derivation of  $T_{sl}$  can be found in the derivation of SAT data.

Hence,

$$V_t = \sqrt{\gamma R_a} \times M \times \sqrt{\frac{T_m}{(1+r \times 0.2M^2)}} \quad (2.15)$$

$$V_t = 20.0468 \times M \times \sqrt{\frac{T_m}{1+r \times 0.2M^2}} \text{ m/sec} \quad (2.16)$$

This can be readily converted to knots using the conversion factor 1m/s = 1.9425 knots. Then the formula becomes [13, 14]:

$$V_t = 38.92 \times M \times \sqrt{\frac{T_m}{1+r \times 0.2M^2}} \text{ knots} \quad (2.17)$$

## 2.5. Mach Number

Mach number is defined as the ratio between the TAS of the aircraft and the speed of sound.

$$M = \frac{TAS}{a_{sl}} \quad (2.18)$$

$$M = \sqrt{5 \times \left[ \left( \frac{P_t}{P_s} \right)^{\frac{2}{7}} - 1 \right]} \quad (2.19)$$

### 2.5.1. Derivation of mach number

#### 2.5.1.1. Derivation for subsonic speeds:

The total and static pressure measurement system is shown schematically in Figure 5.

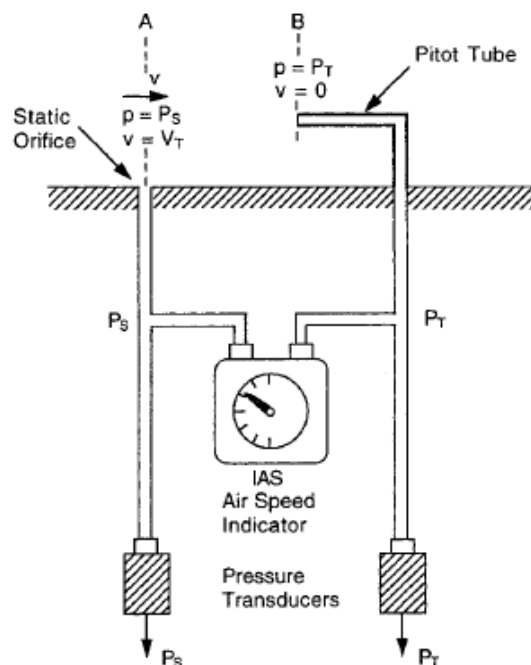

Figure 5 Pressure Measurement System [14]

Consider the first case of low airspeed below  $M = 0.3$ , where air can be considered to be incompressible and the density, therefore, is constant.

The momentum equation for the airflow is:

$$dp + \rho V dV = 0 \quad (2.20)$$

In the free airstream,  $p = P_s$  and  $V = V_t$ , and at the probe face  $p = P_t$  and  $V = 0$ .

Integrating the momentum equation between these limits:

$$\int_{P_s}^{P_t} dp + \rho \int_{V_t}^0 V dV = 0 \quad (2.21)$$

Hence, from the Bernoulli's equation;

$$P_t - P_s = \frac{1}{2} \rho V_t^2 \quad (2.22)$$

$$V_t = \sqrt{\frac{2}{\rho}} \times \sqrt{P_t - P_s} \quad (2.23)$$

It is observed at lower speeds.

However, air is a compressible fluid and its density is not constant. The change in the density due to the high impact pressures resulting from high airspeeds must therefore be taken into account. Assuming adiabatic flow, the relationship between pressure and density is [14]:

$$P = K \times \rho^\gamma \quad (2.24)$$

From which derived is:

$$\rho = \left( \frac{1}{K\bar{\gamma}} \right) \times P\bar{\gamma}^{\frac{1}{\gamma}} \quad (2.25)$$

Substituting for  $\rho$  in the momentum equation:

$$dp + \rho V dV = 0 \quad (2.26)$$

$$dp + \left( \left( \frac{1}{K\bar{\gamma}} \right) \times P\bar{\gamma}^{\frac{1}{\gamma}} \right) V dV = 0 \quad (2.27)$$

In free airstream  $p = P_s$  and  $V = V_t$ , and at the probe face,  $p = P_t$  and  $V = 0$ . Rearranging the equation (2.27) and integrating it between limits given in (2.21), it becomes:

$$\int_{P_s}^{P_t} P\bar{\gamma}^{\frac{1}{\gamma}} dp + \left( \frac{1}{K\bar{\gamma}} \right) \int_{V_t}^0 V dV = 0 \quad (2.28)$$

$$\frac{\gamma}{\gamma-1} \left[ P_t^{\frac{\gamma-1}{\gamma}} - P_s^{\frac{\gamma-1}{\gamma}} \right] = \left( \frac{1}{K\bar{\gamma}} \right) \frac{V_t^2}{2} \quad (2.29)$$



From equation (2.25), substituting for  $K^{\frac{1}{\gamma}}$  in equation (2.30) and rearranging gives:

$$\frac{P_t}{P_s} = \left[ 1 + \frac{\gamma-1}{2} \times \frac{\rho}{\gamma P_s} \times V_t^2 \right]^{\frac{\gamma}{\gamma-1}} \quad (2.30)$$

$\frac{\gamma \times P_s}{\rho} = A^2$  and taking  $\gamma = 1.4$  in (2.28) gives:

$$\frac{P_t}{P_s} = \left[ 1 + 0.2 \frac{V_t^2}{A^2} \right]^{3.5} \quad (2.31)$$

and

$$Q_c = P_s \left[ \left( 1 + 0.2 \times \frac{V_t^2}{A^2} \right)^{3.5} - 1 \right] \quad (2.32)$$

$Q_c$  is  $P_t - P_s$ , which is known as impact pressure.

### 2.5.1.2. Derivation for supersonic speeds:

The aerodynamic theory involved in deriving the relationship between  $\frac{P_t}{P_s}$  and Mach

Number  $\frac{V_t}{A}$  at supersonic speeds ( $M > 1$ ) is beyond the scope of this thesis.

The formula relating pressure ratio  $\frac{P_t}{P_s}$  and Mach number derived by Rayleigh is therefore set out below without further explanation. This can be found suitable in aerodynamics books.

$$\frac{P_t}{P_s} = \frac{\left[ \frac{(\gamma+1)(V_t^2)}{2(A^2)} \right]^{\frac{\gamma}{\gamma-1}}}{\left[ \frac{2\gamma(V_t^2)}{(\gamma+1)(A^2)} - \frac{(\gamma-1)}{(\gamma+1)} \right]^{\frac{1}{\gamma-1}}} \quad (2.33)$$

Substituting for  $\gamma = 1.4$  in equation (2.34) and rearranging gives:

$$\frac{P_t}{P_s} = \frac{166.92 \left(\frac{V_t}{A}\right)^7}{\left[7\left(\frac{V_t^2}{A^2}\right) - 1\right]^{2.5}} \quad (2.34)$$

$$Q_c = P_s \left[ \frac{166.92 \left(\frac{V_t}{A}\right)^7}{\left[7\left(\frac{V_t^2}{A^2}\right) - 1\right]^{2.5}} - 1 \right] \quad (2.35)$$

Now, Mach Number can be derived from formulas (2.36a) and (2.36b):

$$\frac{P_t}{P_s} = \left[1 + 0.2 \frac{V_t^2}{A^2}\right]^{3.5} \quad (2.36a) \quad \text{and} \quad \frac{P_t}{P_s} = \frac{166.92 \left(\frac{V_t}{A}\right)^7}{\left[7\left(\frac{V_t^2}{A^2}\right) - 1\right]^{2.5}} \quad (2.36b)$$

Substituting  $M = \frac{V_t}{A}$  for subsonic speeds:

$$\frac{P_t}{P_s} = [1 + 0.2 M^2]^{3.5} \quad (2.37)$$

and for supersonic speeds it becomes [14]:

$$\frac{P_t}{P_s} = \frac{166.92 M^7}{(7 \times M^2 - 1)^{2.5}} \quad (2.38)$$

## 2.6. Temperature Parameters

There are two temperature parameters calculated. These are namely TAT and SAT. TAT is defined as temperature sensed by the total air temperature sensor. SAT is defined as temperature of the static air:

$$T_S = \frac{T_T}{1 + 0.2M^2} \quad (2.39)$$

M stands for Mach number,  $T_s$  stands for SAT and  $T_t$  stands for temperature sensed by the TAT Sensor.

### 2.6.1. Derivation of SAT

The temperature sensed by the temperature probe in the air stream is the free airstream temperature plus the kinetic rise in temperature due to the air being brought partly or wholly to rest relative to the sensing probe.

The kinetic rise in temperature can be obtained by application of Bernoulli's equation to compressible flow and assuming the pressure changes are adiabatic.

For unit mass of air

$$\frac{P_1}{\rho_1} + \frac{1}{2}V_1^2 + E_1 = \frac{P_2}{\rho_2} + \frac{1}{2}V_2^2 + E_2 \quad (2.40)$$

$P_1, \rho_1, V_1, E_1$  and  $P_2, \rho_2, V_2, E_2$  represent pressure, density, velocity and internal energy at two points in a streamline flow, namely in the free airstream and at the probe.

By the gas law

$$\frac{P_1}{\rho_1} = R_a T_1 \quad (2.41a) \quad \text{and} \quad \frac{P_2}{\rho_2} = R_a T_2 \quad (2.41b)$$

In the free airstream,  $V_1 = V_T$  and  $T_1 = T_S$ , and at a stagnation point at the probe  $V_2 = 0$  and  $T_2 = T_T$ .

Substituting these values in (2.40), this equation (2.41a) and (2.41b) becomes

$$\frac{1}{2}V_T^2 = (E_2 - E_1) + R_a(T_T - T_S) \quad (2.42)$$

The change in internal energy is converted into heat and is given by

$$(E_2 - E_1) = JC_v(T_T - T_S) \quad (2.43)$$

J is the mechanical equivalent of heat (Joule's constant) and  $C_v$  is the specific heat of air at constant volume. Hence,

$$\frac{1}{2}V_T^2 = (JC_v + R_a)(T_T - T_S) \quad (2.44)$$

From thermodynamic theory,

$$R_a = J(C_p - C_v) \quad (2.45)$$

$C_p$  is the specific heat of air at a constant pressure. Combining equations will provide

$$\frac{1}{2}V_T^2 = \frac{R_a C_p}{(C_p - C_v)} (T_T - T_S) \quad (2.46)$$

Rearranging and substituting  $\gamma = C_p/C_v$ , (2.44) becomes

$$T_T - T_S = \frac{(\gamma-1)}{2} \times \frac{1}{\gamma R_a} \times V_T^2 \quad (2.47)$$

It is known that

$$A^2 = \gamma R_a T_S \quad (2.48)$$

Substituting  $\frac{A^2}{T_S}$  for  $\gamma R_a$  and using  $\gamma = 1.4$  in yields for the SAT as

$$T_S = \frac{T_T}{(1+0.2M^2)} \quad (2.49)$$

## CHAPTER 3

### DETAILED DESCRIPTION OF THE SYSTEM DEVELOPED

In this thesis a CADS on a card is developed. This CADS combines the ADC and AOA computers on a card. This way of combining these two subsystems on a card is the improvement that is introduced. First development is the CADS on the card. Then, in order to test and verify the system developed, a test environment had to be developed, which is called the SC. SC provides the necessary inputs, simulated in accordance with a flight scenario for a certain generic platform, to the CADS.

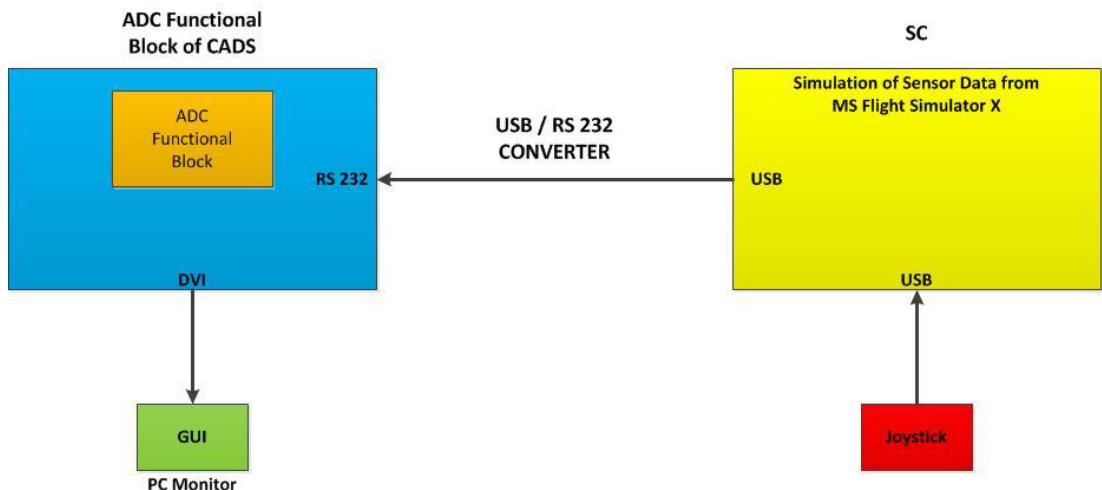

Figure 6 Demonstration of the System Architecture

### **3.1. Properties of the SC**

The SC, developed within the framework of this thesis, will communicate with the CADs, also developed on a card within the framework of this thesis. The SC will send the simulated input parameters to the CADs. The calculated parameters will be monitored on the liquid crystal display (LCD) panel which is connected to the CADs.

The SC has a core 2 duo Intel based 64 bit processor, 4 GB of random access memory (RAM), 1 GB video card. The SC will communicate with the CADs via RS 232 serial communication protocol. The operating system (OS) that is chosen for the SC is Windows XP. The simulation software running on the SC has been developed with C# programming language.

Microsoft Flight Simulator X is used on the SC to get required inputs, which are listed in Tables 1 and 2, from running simulation. The SC has the Microsoft Flight Simulator X with software development kit (SDK) and Microsoft Visual Studio 2010 Ultimate edition installed on. The reason for installing Microsoft Flight Simulator is that it enables the retrieval of aircraft data like the real environment. Flight Simulator X (FSX) is the latest version of Microsoft Flight Simulator after Microsoft Flight Simulator 2004. For Flight Simulator's detailed information on its development, history and etc. one can refer to the Appendix A1. On the software side of the flight simulator, the program running on the SC system gets the real time simulation environment data from the flight simulator via using the flight simulator's SDK. Flight simulator gives the opportunity of getting data from or setting data to it. There are two different types of SDK available, namely Microsoft ESP and Microsoft Flight Simulator X SDK. Both SDKs have the same properties except for the licensing. For having the right of a developed system and in order to sell it as if it was your product you need to use Microsoft ESP and write your program using its software development kit. However for personal use and if one does not aim for profiting FSX software development kit is eligible with its lower

cost. The details of FSX can be found in the Appendix A1. All of the sensor data will be flowing to the system on-time from the simulator. The simulation parameters are given in Table 1 and Table 2 [15]:

**Table 1 Aircraft Environment Data**

<b>Simulation Variable</b>	<b>Description</b>	<b>Units</b>	<b>Settable</b>
<b>Ambient Temperature</b>	Ambient temperature	Celsius	No
<b>Ambient Pressure</b>	Ambient pressure	Inches of mercury, inHg	No
<b>Barometer Pressure</b>	Barometric pressure	Millibars	No
<b>Sea Level Pressure</b>	Barometric pressure at sea level	Millibars	No
<b>TAT</b>	Total air temperature is the air temperature at the front of the aircraft sensed from the TAT Probe	Degree of Celsius	No

**Table 2 Aircraft Landing Gear Data**

<b>Simulation Variable</b>	<b>Description</b>	<b>Units</b>	<b>Settable</b>
<b>GEAR POSITION: <i>index</i></b>	Position of landing gear: 0 = unknown 1 = up 2 = down	Enum	Yes

In the Figure 7 the SC software user interface can be seen. When its exe is run window in Figure 7 is opened. But before running the program in Figure 7 it would be better to start Microsoft Flight Simulator X. After opening FSX run the SC software and see the opened user interface. Later when the button Connect

is pressed the SC's serial port settings are done. Then by the use of SimConnect SDK commands explained before, program connects to Flight Simulator's simconnect object. As the connection established it is ready to get the desired simulation variables data from FSX and on the SC software user interface "Connection Established" phrase appears, and Connect button becomes dimmed while Disconnect button becomes undimmed. Before starting a flight the operator should also press the Request button in order to start desired data acquisition. When Request button is pressed a continuous data request, gathering the requested data, sending it over serial port and another request session starts. This continues repeatedly until the program is terminated. Moreover, Request button becomes inactive (dimmed) after it is pressed and Stop button becomes active (undimmed). By the end of this process simulated environment data is continuously supplied to the CADs over the RS-232 serial port. If data request is to be stopped, Stop button should be pressed, which enables Request button. Lastly in order to disconnect from SimConnect object, Disconnect button should be pressed.

For detailed examination of the simulation system's program architecture, see the code in the Appendix A2.

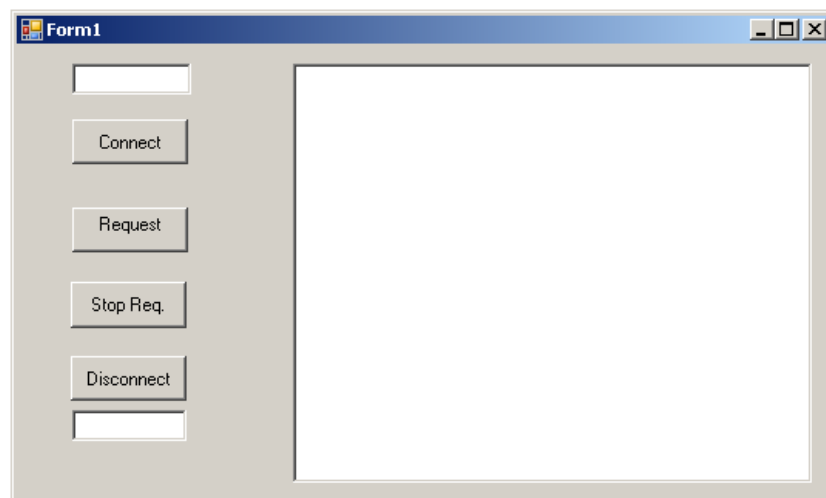

Figure 7 GUI of the SC



## CHAPTER 4

### CADS VERSUS REAL EQUIPMENT

#### 4.1. Real ADC

An example of a real ADC internal architecture is given in Figure 8:

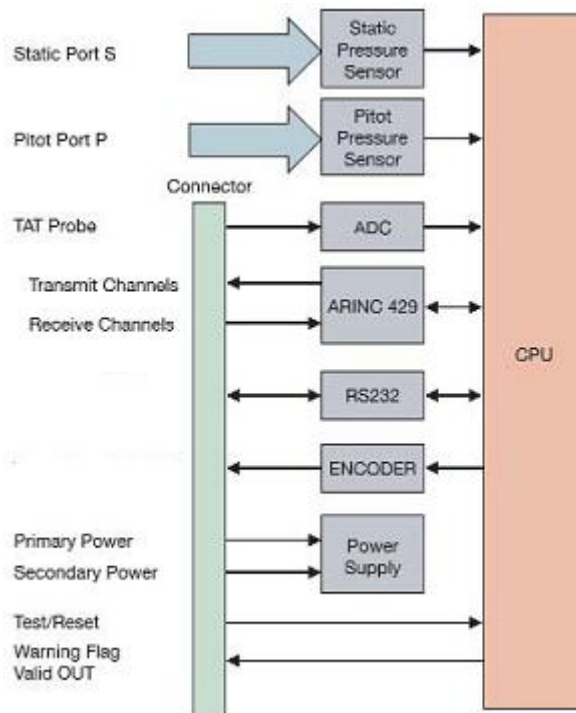

Figure 8 An example ADC Internal Architecture [16]

The example avionics architecture around the example equipment is shown in Figure 9:

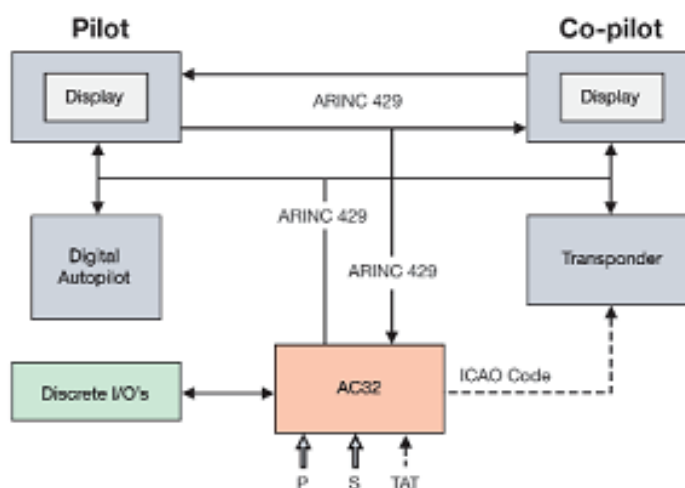

Figure 9 Typical Architecture of ADC Given by Manufacturer [16]

The example ADC has ARINC 429 interface for other avionics equipment and RS 232 interface for the maintenance mode.

As mentioned in the previous chapters, there are some standards to be obeyed when designing the equipment. These standards can be grouped as:

- Functionality and Performance Standards (TSO C106, SAE AS 8002, FAA TSO C88a, SAE AS 8003)
- Environmental Standards (RTCA/DO-160)
- Communication Standards (ARINC 429, RS 232)
- Software Standards (RTCA/DO-178B).

#### **4.1.1. Functionality and performance standards**

Equipment manufacturers are trying to comply with TSOs and SAEs related with the ADC. Since TSOs are giving reference to SAE AS, it is important to understand what SAE AS 8002 and 8003 specify.

SAE AS 8002 covers ADC and its official name is “Air Data Computer - Minimum Performance Standard”. It states the mandatory and optional parameters which will be given by the ADC when connected to sources of aircraft electrical power, static pressure, total pressure, outside air temperature, and others specified by the equipment manufacturer. The mandatory parameters are:

- Pressure Altitude
- Pressure Altitude, Baro-Corrected
- Vertical Speed
- Calibrated Airspeed
- Mach Number
- Maximum Allowable Airspeed
- Overspeed Warning
- Total Air Temperature.

In addition, the computer may supply one or more of the following signals:

- Pressure Altitude, Digitized
- Equivalent Airspeed
- True Airspeed
- Static Air Temperature
- Altitude Hold
- Airspeed Hold

- Mach Hold
- Angle of Attack
- Flight Control Gain Scheduling
- Others [17].

In addition to these parameter lists, SAE AS 8002 states the required accuracy in calculated parameters:

- Tolerance in Pressure Altitude is +/-25 feet (+/- 8 meters) up to 5000 feet, +/-30 feet (+/- 9 meters) from 5000 feet up to 8000 feet. The AS specifies the allowable tolerances up to 50000 feet.
- Tolerance in Baro-Corrected Pressure Altitude is +/-40 feet (+/- 12 meters) if the Barometric Setting Scale is 22.00 inch Hg, +/-35 feet (+/- 11 meters) if the Barometric Setting Scale is 23.27 inch Hg. The AS specifies the allowable relation between barometric setting and altitude up to the Barometric Setting of 30.98 inch Hg.
- Tolerance in Calibrated Airspeed (CAS) is +/-5 knots (+/- 9.3 km/hour) up to 50 knots, +/-3 knots (+/- 6.5 km/hour) from 50 knots up to 80 knots. The AS specifies the allowable tolerances up to 450 knots.
- Tolerance in TAT is +/-1.5 °C from -70 °C up to +50 °C.
- AS 8002 gives a relation between calculated Mach Number, the tolerance in this calculated Mach Number and altitude. Tolerance in Mach Number is 0.012 for altitudes up to 10000 feet and for Mach Numbers up to 0.4. The AS specifies the allowable tolerances up to 1 Mach and up to 50000 feet.

SAE AS 8003 establishes the minimum safe performance requirements for 100 feet (30.48 meters), incremental automatic pressure altitude code generating equipment. It is intended that the code generator be operated by a pressure altitude device which may also operate the pressure altitude indicator normally

used to maintain flight altitude. If there is a Second Surveillance Radar (SSR) Transponder equipment in the avionics architecture of A/C, then there should be a pressure altitude data flow from the ADC to SSR Transponder. For that reason AS 8003 becomes a critical requirement document for the ADC. [17]

#### 4.1.2. Environmental standards

Functionality and performance standards define the minimum performance under environmental conditions and when defining the performance it references RTCA – DO 160. Table 3 shows some of the criteria included in DO 160:

**Table 3 Some of the Criteria Included in DO 160 [5]**

<b>Name</b>	<b>Description</b>
<b>Shock &amp; Crash Safety</b>	This aircraft type dependent test checks the effects of mechanical shock. Crash safety test insures the item does not become a projectile in a crash. The norm describes the test procedure for airborne equipment.
<b>Temperature</b>	This checks the effects of temperature on the system. Condensation also can be a factor coming from cold temperatures.
<b>Altitude</b>	These tests check the effects (in terms of performance) of altitude, including loss of cabin pressure on the device/system/equipment. Factors tested include dielectric strength, cooling under low pressure, and resilience to rapid change in air pressure. The norm defines the different temperature profiles under which the equipment must be tested. Due to the variety of aircraft, the equipment are classified in categories
<b>Humidity</b>	These tests under humidity check the effects of water dripping / splashing on the unit (corrosion).
<b>Power input</b>	Input power conducted emissions and susceptibility, transients, drop-outs and hold-up. The power input tests simulate conditions of aircraft power from before engine start to after landing including emergencies.
<b>Vibration</b>	Aircraft type dependent test checks the effects of vibration.
<b>RF Emission and Susceptibility</b>	Radio frequency energy: - radiated emissions and radiated susceptibility via an (Electromagnetic reverberation chamber).

### 4.1.3. Communication standards

Today most of the modern avionics ADCs use ARINC 429 serial communication protocol to make interface with the other equipment. ADCs have also RS 232 or RS 422 serial communication protocol for maintenance purposes. RS 232 and RS 422 are well known serial communication protocols. ARINC 429 is more specific to aviation but it is also simple like RS 232 and RS 422.

ARINC 429 is a very simple, point-to-point protocol. There can be only one transmitter on a wire pair. The transmitter is always transmitting either 32-bit data words or the NULL state. There is at least one receiver on a wire pair; there may be up to 20. ARINC 429 communication protocol message structure is given in the Figure 10.

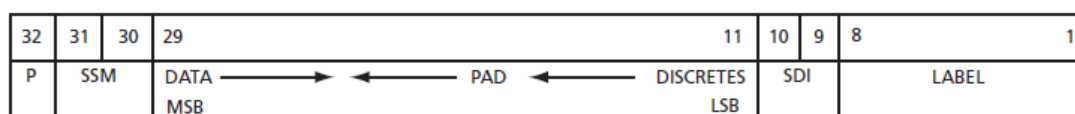

Figure 10 ARINC 429 Message Structure [18]

The details of ARINC 429 can be achieved from internet. [19]

ADCs have two types of ARINC 429 communications in terms of speed of data. One is 12.5 kilobits per second (kbps) which is called as low speed and the other is 100 kbps which is called as high speed. Whole modern ADCs have a speed selection pin which determines the speed of the ARINC 429 channels (low or high). Another important point is refresh/update rates of the ARINC 429 messages. According to ARINC 429 standard, the altitude related messages are updated 16 times in a second, the temperature related messages are updated 2 times in a second and the other messages are updated in 8 times in a second.

#### 4.1.4. Software standards

As mentioned in previous chapters, DO-178B, Software Considerations in Airborne Systems and Equipment Certification is the title of a document published by RTCA, Incorporated.

From the beginning of the system design, safety assessment process and hazard analysis are made by examining the effects of a failure condition in the system. The failure conditions are categorized by their effects on the aircraft, crew, and passengers.

- **Catastrophic** - Failure may cause a crash. Error or loss of critical function required to safely fly and land aircraft.
- **Hazardous** - Failure has a large negative impact on safety or performance, or reduces the ability of the crew to operate the aircraft due to physical distress or a higher workload, or causes serious or fatal injuries among the passengers. (Safety-significant)
- **Major** - Failure is significant, but has a lesser impact than a Hazardous failure (for example, leads to passenger discomfort rather than injuries) or significantly increases crew workload (safety related)
- **Minor** - Failure is noticeable, but has a lesser impact than a Major failure (for example, causing passenger inconvenience or a routine flight plan change)
- **No Effect** - Failure has no impact on safety, aircraft operation, or crew workload.

According to results of the safety assessment, the Design Assurance Level (DAL) is determined.

DO-178B alone is not intended to guarantee software safety aspects. Safety attributes in the design and as implemented as functionality must receive additional mandatory system safety tasks to drive and show objective evidence of meeting

explicit safety requirements. Typically IEEE STD-1228-1994 Software Safety Plans are allocated and software safety analyses tasks are accomplished in sequential steps (requirements analysis, top level design analysis, detailed design analysis, code level analysis, test analysis and change analysis). These software safety tasks and artifacts are integral supporting parts of the process for hazard severity and DAL determination to be documented in system safety assessments (SSA). The certification authorities require and DO-178B specifies the correct DAL be established using these comprehensive analyses methods to establish the software level A-E. Any software that commands, controls, and monitors safety-critical functions should receive the highest DAL - Level A. It is the software safety analyses that drive the system safety assessments that determine the DAL that drives the appropriate level of rigor in DO-178B. The system safety assessments combined with methods such as SAE ARP 4754A determine the after mitigation DAL and may allow reduction of the DO-178B software level objectives to be satisfied if redundancy, design safety features and other architectural forms of hazard mitigation are in requirements driven by the safety analyses. Therefore, DO-178B central theme is design assurance and verification after the prerequisite safety requirements has been established.

The number of objectives to be satisfied (eventually with independence) is determined by the software level A-E. The phrase "with independence" refers to a separation of responsibilities where the objectivity of the verification and validation processes is ensured by virtue of their "independence" from the software development team. In some cases, an automated tool may be equivalent to independence.



**Table 4 DO 178B Software Levels**

<b>Level</b>	<b>Failure condition</b>	<b>Objectives</b>	<b>With independence</b>
<b>A</b>	Catastrophic	66	25
<b>B</b>	Hazardous	65	14
<b>C</b>	Major	57	2
<b>D</b>	Minor	28	2
<b>E</b>	No effect	0	0

According to the information given in Table 4, most of the ADCs are designed at DO 178B Software Level A since erroneous data given by ADC will lead to catastrophic failures.

## CHAPTER 5

### GENERAL VIEW OF THE SC SYSTEM SOFTWARE DESIGN

In this system C# (Microsoft .NET Language) is used. First of all in order to do programming using C# it is needed to add Microsoft.FlightSimulator.SimConnect as a new reference to the project. Besides adding Microsoft.FlightSimulator.SimConnect, System.Runtime.InteropServices should be added. Below code snippet shows how to add the two references.

```
using Microsoft.FlightSimulator.SimConnect
```

```
using System.Runtime.InteropServices.
```

Then list of C# methods used in the SC system and their functionality are explained.

`private void InitializeSerial():` Initializes the serial port. This method creates the serial port object with the desired settings and opens the serial port for connection.

`protected override void DefWndProc(ref Message m):` This method makes simconnect client send a win32 message when there is a packet to process. `ReceiveMessage` must be called to trigger the events. This model keeps simconnect processing on the main thread.

`private void setButtons(bool bConnect, bool bGet, bool bStop, bool bDisconnect):` This method makes the buttons on the user interface dimmed or undimmed with respect to given inputs to the method.

`private void closeConnection():` This method closes the connection to the `simconnect` object, discards the object and writes a connection closed message on the user interface.

`private void initDataRequest():` This method sets up all the `SimConnect` related data definitions and event handlers.

`void simconnect_OnRecvOpen(SimConnect sender, SIMCONNECT_RECV_OPEN data):` When connection to `simconnect` object is established this method displays the text indicating connection established message. This is an event handler.

`void simconnect_OnRecvQuit(SimConnect sender, SIMCONNECT_RECV data):`

When FSX is closed this method calls the `closeConnection()` method and displays the text indicating the connection closure.

`Void simconnect_OnRecvException(SimConnect sender, SIMCONNECT_RECV_EXCEPTION data):` This method displays the received exception message from exception's data. This method is an event handler.

`private void Form1_FormClosed(object sender, FormClosedEventArgs e):` This method is another method which calls the `closeConnection()` method. This calls `closeConnection()` method when user interface is closed.

`void simconnect_OnRecvSimobjectDataBytype(SimConnect sender, SIMCONNECT_RECV_SIMOBJECT_DATA_BYTYPE data):` This method continuously requests desired data from the `simconnect` object. After each request and data collection method converts the data structure to byte array and sends it over the serial port. This method is some like callback which is called when an action occurs. This is an event handler.

byte[] ToByteArrayConverter(object anything): This method converts the data structure gathered from simconnect object to byte array which is an eligible type to send over serial port. This method is used by the previous method.

static void ByteArrayToStructureConverter(byte[] Array, ref object anything): This method does the reverse operation of the previous method. This method converts the byte array to the data structure.

private void MyConnect(): Creates the new simconnect object and calls the method initDataRequest().

private void buttonConnect\_Click(object sender, EventArgs e): Initializes the serial port by the method call InitializeSerial() and after that calls the method MyConnect() for data request.

private void buttonDisconnect\_Click(object sender, EventArgs e): Closes the connection bu calling closeConnection().

private void buttonRequestData\_Click(object sender, EventArgs e): This method requests the first data and makes it recall continuously itself.

private void MyRequestData(): The method directly requests data from FSX SDK. This is used by the buttonRequestData\_Click method and simconnect\_OnRecvSimobjectDataBytype method.

private void buttonStopRequest\_Click(object sender, EventArgs e): This stops the request operation when Stop Request button is clicked.

void displayText(string s): This method displays the desired string on the user interface textbox.

Operating system is the last general issue in SC software architecture. In this thesis, software platform for SC is based on Microsoft Windows operating systems.

## CHAPTER 6

### CONFIGURATION ITEMS

For a general system structure of a system developed, there exist two types of configuration items to be listed. These are hardware configuration items (HWCI) and software configuration items (SWCI).

#### **6.1. Hardware Configuration Items:**

The SC is the simulation computer which sends the simulated environment data to the CADs over serial port. For environment simulation the SC runs some special programs. To run these simulation programs, to gather data and to send gathered data over serial port together much more performance is needed. For meeting this high performance a powerful hardware configuration is used. The hardware specifications for the SC are listed below:

- Intel Core 2 Duo 2.13 giga hertz (GHz) Processor
- USB-to-Serial Converter
- Hard disk
- 4 GB RAM
- Motherboard
- DVD Writer.

## 6.2. The Software Configuration Items:

As one can observe from Figure 11 shows the SC system SWCI, which contain the items of Platform, Development Environment, and Software.

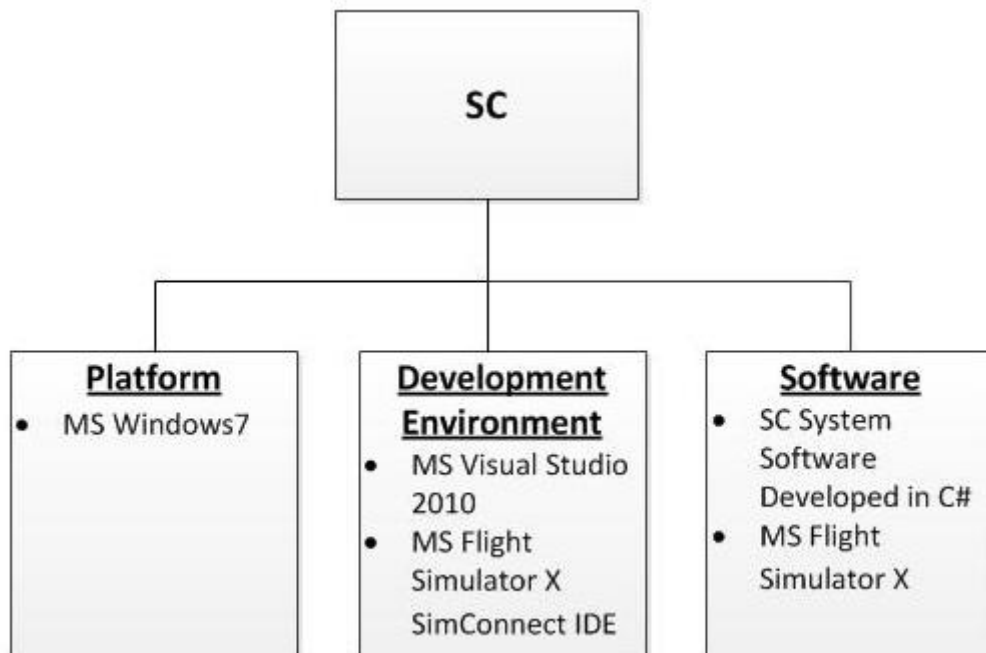

Figure 11 The SWCI of the Developed System

The SC Software Configuration Item parts are listed below:

- Microsoft Windows7 (Platform)
- Microsoft Visual Studio 2010 (Development Environment)
- Microsoft Flight Simulator X SimConnect Integrated Development Environment
- SC System Software Developed in C# (Software)
- Microsoft Flight Simulator X (Software)

## **CHAPTER 7**

### **TEST AND VERIFICATION OF THE SYSTEM DEVELOPED**

In real life, the CADS system should have static and total pressure ports. The equipment should directly get the pressure and then convert the pressure into electrical signal inside. TAT sensors are potentiometers actually. Therefore, there should be a mechanism to measure the voltage drop on the TAT sensor's resistance.

Real system should be verified in a lab environment with real sensors. There are static and total pressure sources for the ADC equipment development purposes. Test team of the equipment uses the pressure sources. They enter pre-defined static and total pressure values. They also know the corresponding airspeed and altitude values by theory. Therefore by means of these setups, the test crew makes the verification. The temperature verification is made also in the same manner. The TAT sensor should be warmed up and the verification should be made via controlling the output of the CADS.

Since there is no budget to use real sensors in this project, Microsoft FSX is used to get the simulated sensors data. The block diagram of SC system which sends simulated variables is given in Figure 12.

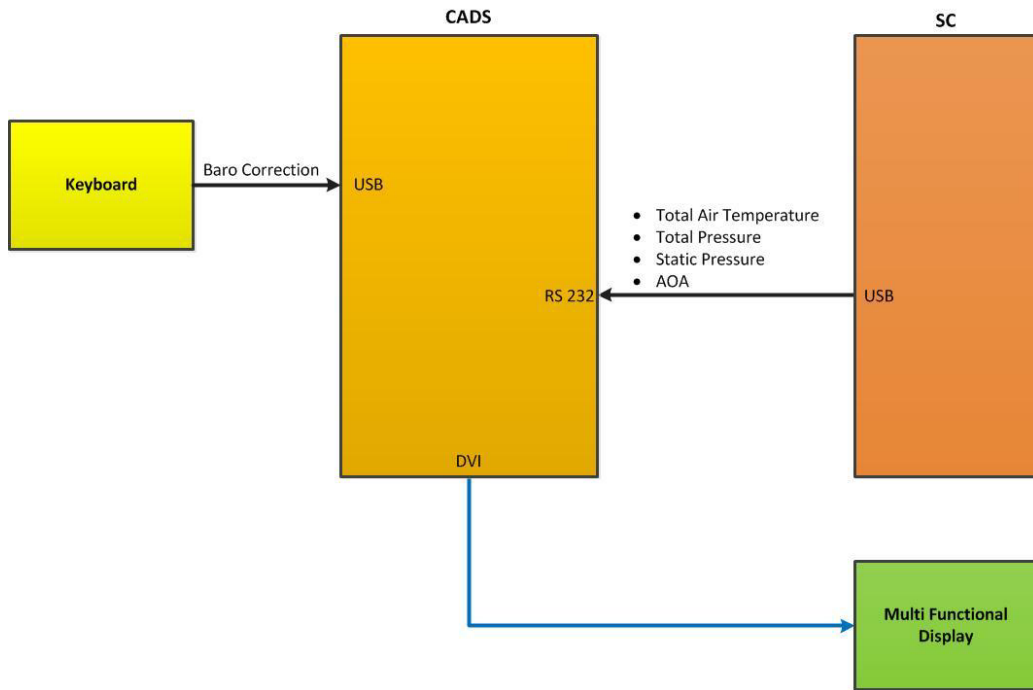

**Figure 12 CADS System Verification of the System Developed**

The comparison graphs of the calculated parameters are given in figures. Note that the horizontal axes show the number of samples used when this graph is plotted.



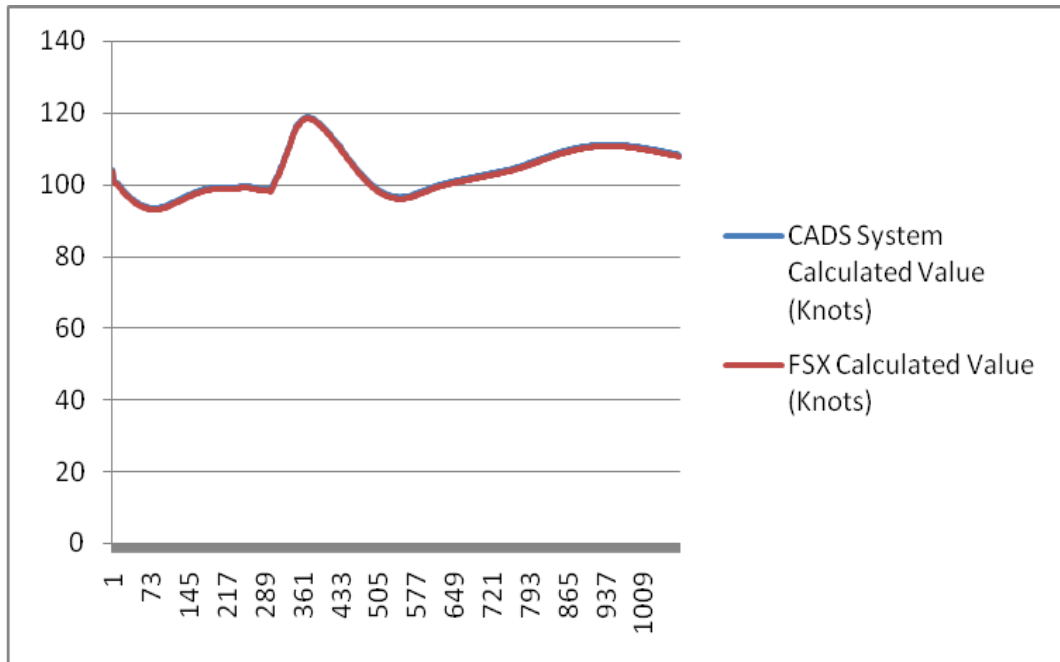

**Figure 13 TAS Calculated By CADS vs. FSX**

According to SAE AS 8002A, minimum allowable tolerance in airspeed calculation is +/- 2 knots and maximum allowable tolerance is +/- 5 knots. The details of these tolerances could be reached from the standard. 1079 sample data has been used to plot Figure 13. The maximum difference between TAS parameter calculated by CADS and FSX is 0.98 knots which satisfies the standard used for ADC design.

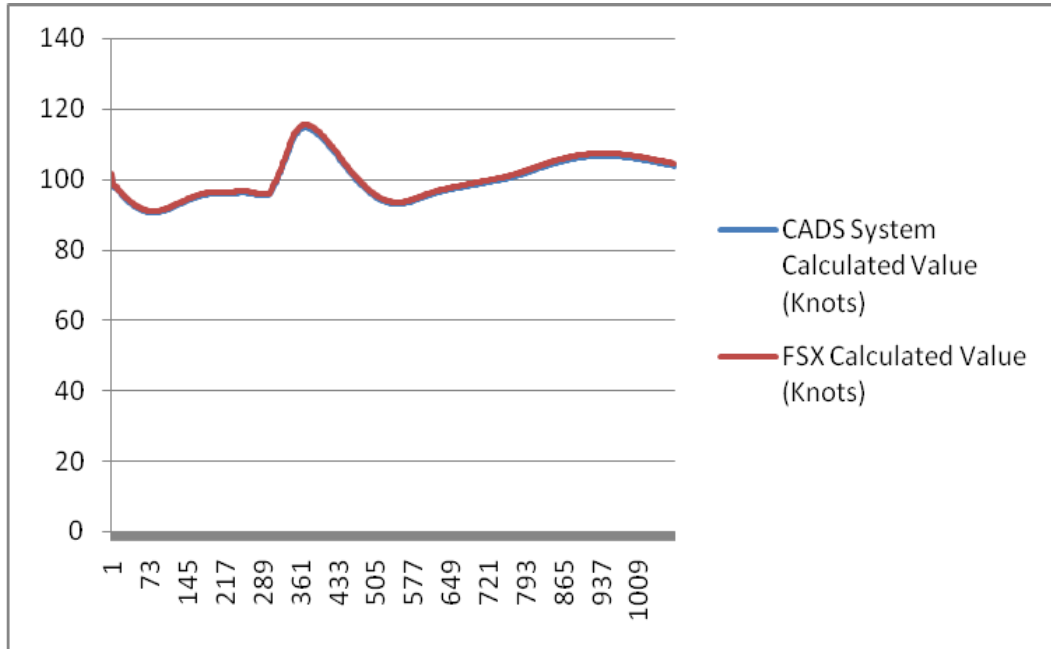

**Figure 14 IAS Calculated By CADS vs. FSX**

According to SAE AS 8002A, minimum allowable tolerance in airspeed calculation is +/- 2 knots and maximum allowable tolerance is +/- 5 knots. The details of these tolerances could be reached from the standard. 1079 sample data has been used to plot the graph in Figure 14. The maximum difference between IAS parameter calculated by CADS and FSX is 0.79 knots which satisfies the standard used for ADC design.

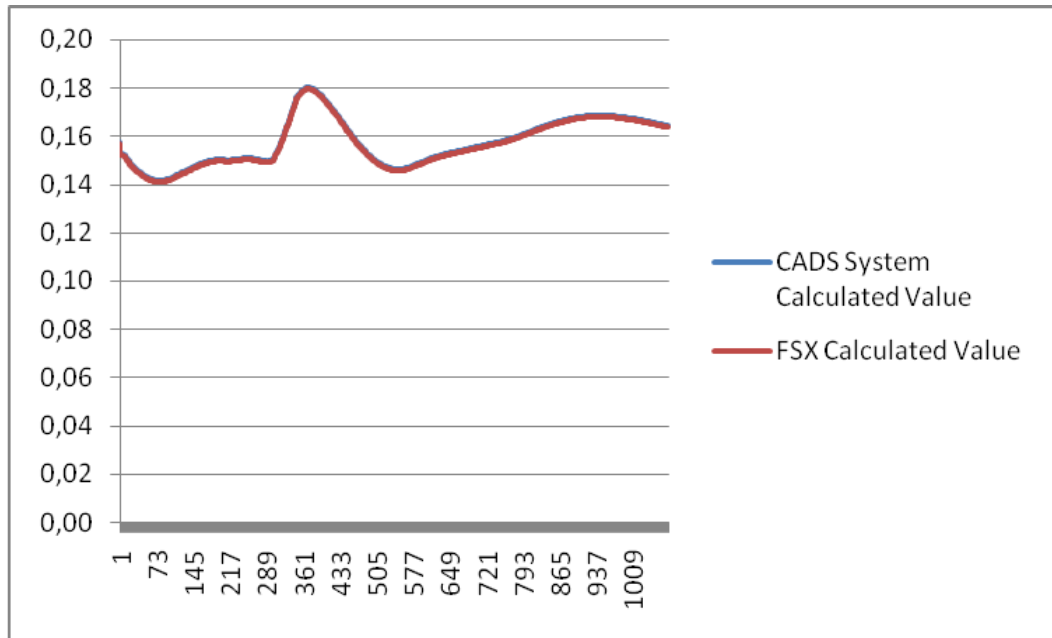

**Figure 15 Mach Number Calculated By CADs vs. FSX**

According to SAE AS 8002A, minimum allowable tolerance in Mach Number calculation is +/- 0.0075 and maximum allowable tolerance is +/- 0.015. The details of these tolerances could be reached from the standard. 1079 sample data has been used to plot the graph in Figure 15. The maximum difference between Mach Number calculated by CADs and FSX is 0.001 knots which satisfies the standard used for ADC design.

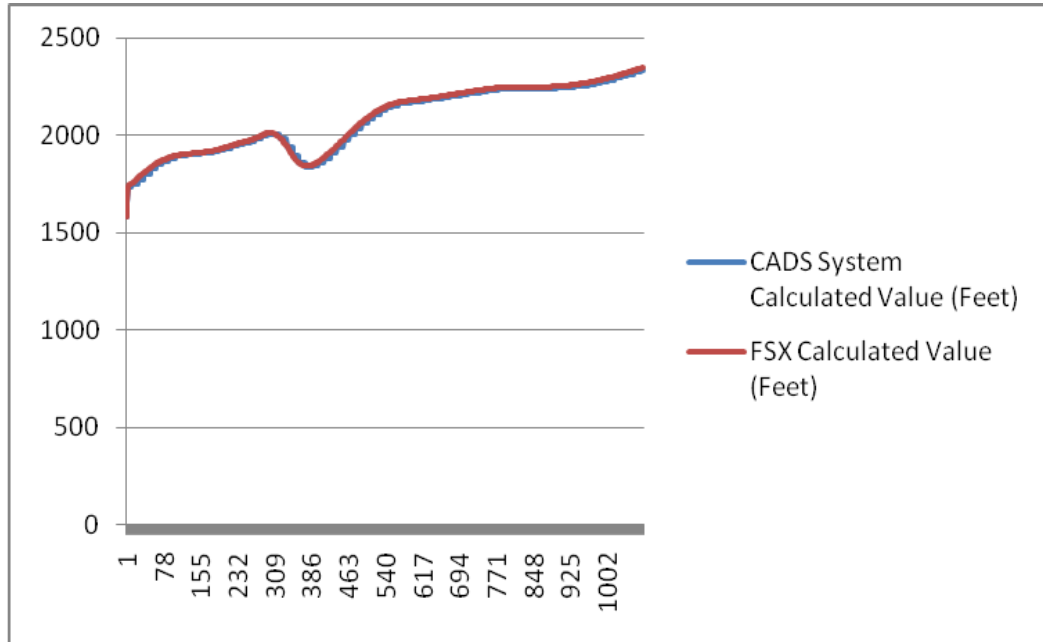

**Figure 16 Pressure Altitude Calculated By CADS vs. FSX**

According to SAE AS 8002A, minimum allowable tolerance in Pressure Altitude calculation is +/- 25 feet and maximum allowable tolerance is +/- 125. The details of these tolerances could be reached from the standard. 1079 sample data has been used to plot the graph in Figure 16. The maximum difference between Pressure Altitude parameter calculated by CADS and FSX is 44 knots which satisfies the standard used for ADC design.

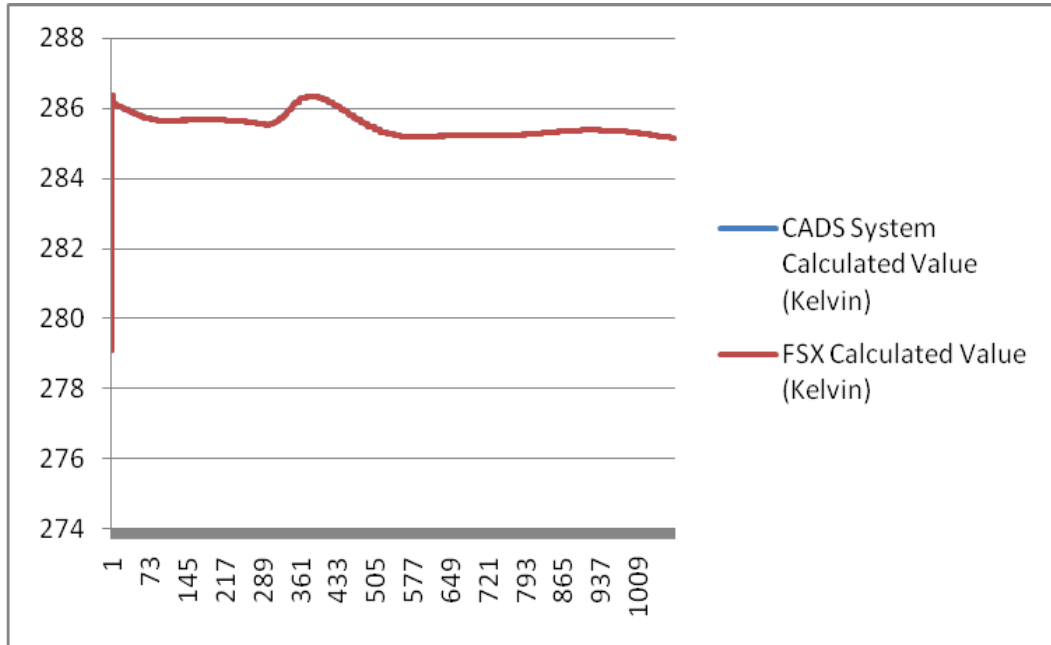

**Figure 17 TAT Calculated By CADS vs. FSX**

According to SAE AS 8002A, allowable tolerance in TAT calculation is +/- 1.5 °C. The details of these tolerances could be reached from the standard. 1079 sample data has been used to plot the graph in Figure 17. The maximum difference between TAT parameter calculated by CADS and FSX is 0 °C which satisfies the standard used for ADC design.

The SC has five outputs in other words these are inputs of CADS. These outputs are supplied to CADS via serial port as digital signals. The full list and ranges of the outputs of the SC system are given in the Table 5.

**Table 5 List of the Inputs of the CADS**

No	Parameter Name	Range
1	Static Pressure	2 – 32 in Hg
2	Total Pressure	0 – 47 in Hg
3	Impact Pressure	0 – 15 in Hg
4	Baro Correction	20.67 to 31.00 in Hg
5	Total Air Temperature	- 60 to + 99 degrees of Celsius

## **CHAPTER 8**

### **CONCLUSION**

In this thesis the ADC functionalities of a CADs is developed and the developed CADs is tested by a SC on a PC, which is also developed within the framework of this thesis.

The ADC is among the most safety critical and basic equipment for a flying system. Therefore, the validity and correctness of the calculated parameters are very important. For the output of the ADC to be correct and valid, it should be supplied with necessary inputs. It needs pressure inputs at a rate of 16 times in a second, and at a rate of temperature parameters 2 times in a second. Therefore, the SC software should obey these restrictions. In real world, equipment developers and system integrators use environmental data simulations as in SC software. Thus SC software has also an industrial validation which means aircraft manufacturers and integrators use this kind of implementation in early phases of their design.. It is important to note that the environmental data generation software does not run on real time operating system. This is also an important detail supporting the validity of the SC software's among avionics industry. A commercial software product of Microsoft FSX, from which SC software get required data for its environmental data generation, is widely used in avionics firms for their laboratory works and demonstrations. After laboratory tests of the ADC with data provided by the SC or the SC-like generator software, the A/C integrators or equipment manufacturers go

one step further and perform their tests with real environmental equipment. After passing the tests done on the ground with real environmental equipment, real flight tests start. Finally the A/C is proven to be flyable.

As it is mentioned in the details of the thesis, the SC software make its communication via RS 232 serial communication protocol. In avionics industry, ARINC 429 or MIL-STD 1553 serial communication protocols are widely used. Therefore using this kind of serial modules in SC could be a one step further from this thesis.

Since the entire ADC calculated parameters have been derived in detail, the required behavior of the ADC with respect to incoming sensor data is obvious. Therefore blocking the pitot port, blocking the static port and the challenging properties like those could be added to the SC software as a future work. The leads and lags in the corresponding sensor data could also be implemented.

There are some parameters which could not be calculated without A/C specific parameters such as the CAS. For the CAS to be calculated the static source error correction (SSEC) table which contains some corrections about the lags and leads caused by installation place of pitot and static pressure ports is needed. This SSEC table can only be prepared and supplied by the A/C integrator or manufacturer. With such a cooperation arranged with an A/C integrator or manufacturer, this parameter calculation can also be achieved.



## REFERENCES

- [1] KARABULUT, M.M., 2011, Development of Angle of Attack (AOA) / Stall Warning Computer Functions of a Combined Air Data and Angle of Attack Computer, Thesis (MSc.), Çankaya University
- [2] [http://rgl.faa.gov/Regulatory and Guidance Library%5Crgtso.nsf/0/FDC3133EED60BDB986256DC600696543?OpenDocument](http://rgl.faa.gov/Regulatory_and_Guidance_Library%5Crgtso.nsf/0/FDC3133EED60BDB986256DC600696543?OpenDocument)
- [3] [http://rgl.faa.gov/Regulatory and Guidance Library%5Crgtso.nsf/0/7F3CE81AFC742A4B86256DC70067B087?OpenDocument](http://rgl.faa.gov/Regulatory_and_Guidance_Library%5Crgtso.nsf/0/7F3CE81AFC742A4B86256DC70067B087?OpenDocument)
- [4] <http://en.wikipedia.org/wiki/DO-178B>
- [5] <http://en.wikipedia.org/wiki/DO-160>

[6] <http://content.answcdn.com/main/content/img/McGrawHill/Aviation/f0609-05.gif>

[7] [http://www.acig.org/exclusives/aero/acig\\_aero05\\_attackers.htm](http://www.acig.org/exclusives/aero/acig_aero05_attackers.htm)

[8] <http://blog.silive.com/sinotebook/2008/08/tat.jpg>

[9] <http://www.goodrich.com/gr-ext-templating/images/Goodrich%20Content/Business%20Content/Sensors%20and%20Integrated%20Systems/Products/Literature%20Listing/4081%20Air%20Data%20Handbook.pdf>

[10] [http://psas.pdx.edu/RocketScience/PressureAltitude\\_Derived.pdf](http://psas.pdx.edu/RocketScience/PressureAltitude_Derived.pdf)

[11] [http://en.wikipedia.org/wiki/True\\_airspeed](http://en.wikipedia.org/wiki/True_airspeed)

[12] [http://en.wikipedia.org/wiki/Adiabatic\\_process](http://en.wikipedia.org/wiki/Adiabatic_process)

[13] [http://en.wikipedia.org/wiki/Heat\\_capacity\\_ratio](http://en.wikipedia.org/wiki/Heat_capacity_ratio)

[14] [R. P. G. Collinson, Chapman & Hall.\(1998\), Introduction to Avionics. 2–6  
Boundary Row, London, SE1 8HN, UK in the Microwave Technology Series.](#)

[15] <http://msdn.microsoft.com/en-us/library/cc526981.aspx>

[16] [http://www.thommenag.ch/standard.cfm?ID\\_n=81&unter=36&haupt=26&lang  
uage=1](http://www.thommenag.ch/standard.cfm?ID_n=81&unter=36&haupt=26&language=1)

[17] <http://standards.sae.org/as8002a/>

[18] [http://www.actel.com/ipdocs/CoreARINC429\\_DS.pdf](http://www.actel.com/ipdocs/CoreARINC429_DS.pdf)

[19] [http://en.wikipedia.org/wiki/ARINC\\_429](http://en.wikipedia.org/wiki/ARINC_429)

[20] <http://blackiceair.net/SDK/sdk%20overview.html>