

S. J. Johnston, H. Jafari, S. P. Moshokoa*, V. M. Ariyan, and D. Baleanu

Laplace homotopy perturbation method for Burgers equation with space- and time-fractional order

DOI 10.1515/phys-2016-0023

Received Nov 12, 2015; accepted Dec 20, 2015

Abstract: The fractional Burgers equation describes the physical processes of unidirectional propagation of weakly nonlinear acoustic waves through a gas-filled pipe. The Laplace homotopy perturbation method is discussed to obtain the approximate analytical solution of space-fractional and time-fractional Burgers equations. The method used combines the Laplace transform and the homotopy perturbation method. Numerical results show that the approach is easy to implement and accurate when applied to partial differential equations of fractional orders.

Keywords: Fractional differential equations; Burgers equation; Homotopy perturbation method; Laplace transform.

PACS: 02.30.Mv; 02.30.Jr

1 Introduction

The space- and time-fractional Burgers equations have been of considerable interest in recent literature [1, 19]. These equations have many applications in science and engineering. The memory effect of the wall friction through the boundary layer results in the fractional derivative. Other systems, such as waves in bubbly liquids and shallow-water waves, give the same form. Some applica-

tions associated with the space-fractional Burgers equation, can be found in, for instance, [20].

The fractional Burgers equation has been considered by several authors recently. In [20], Sugimoto developed an asymptotic and numerical analysis of the generalized Burgers equation with a space-fractional derivative. El-Shahed [2] obtained an analytical solution of the space-fractional Burgers equation with $\beta = \frac{1}{2}$ by considering the Adomian decomposition scheme. Biler, Funaki and Woyczynski considered the existence and uniqueness and self-similar properties of solutions of the space-fractional Burgers equation in [1]. In [15], Momani used the decomposition method to obtain approximate solutions for the generalized Burgers equation with time- and space-fractional derivatives. In [16], Odibat, Momani and Alawneh used the variational iteration method to investigate the effect of varying the order of the time- and space-fractional derivatives on the behaviour of solutions.

The generalized Burgers equation with space- and time-fractional derivatives has been introduced in the form (cf. [15])

$$\frac{\partial^\alpha u}{\partial t^\alpha} + \epsilon u \frac{\partial u}{\partial x} = \nu \frac{\partial^2 u}{\partial x^2} - \eta \frac{\partial^\beta u}{\partial x^\beta}, \quad t > 0, \quad 0 < \alpha, \beta \leq 1, \quad (1)$$

where ϵ, ν, η are parameters. We refer to equation 1 as the time-fractional Burgers equation and to the space-fractional Burgers equation in the cases $\{0 < \alpha \leq 1, \eta = 0\}$ and $\{0 < \beta \leq 1, \alpha = 1\}$ respectively. The fractional derivatives are considered in the Caputo sense. The general response expression contains parameters describing the order of the fractional derivatives which can be varied to obtain various responses. Obviously, the integer-order Burgers equation can be viewed as a special case of the generalized Burgers equation by putting the space- and time-fractional order of the derivative equal to unity. In other words, the ultimate behavior of the fractional system response must converge to the response of the integer order version of the equation.

Some famous methods have been presented to approximate the analytical solution of linear/nonlinear differential equations (see, for example, [6] and [7]). Recently,

S. J. Johnston, H. Jafari: Department of Mathematical Sciences, University of South Africa, PO Box 392, UNISA 0003, South Africa

***Corresponding Author: S. P. Moshokoa:** Department of Mathematics and Statistics, Faculty of Science, Tshwane University of Technology, Arcadia Campus, Building 2-117, Nelson Mandela Drive, Pretoria 0001, South Africa; Email: MoshokoaSP@tut.ac.za

V. M. Ariyan: Department of Mathematical Sciences, Mangosuthu University of Technology, Umlazi, South Africa

D. Baleanu: Department of Mathematics and Computer Science Çankaya University, Ankara, Turkey

the Laplace decomposition method has been suggested by Khuri. In [12, 13], Khuri used Laplace transforms in ADM and approximated the solution of a class of differential equations. In [9] using a similar idea to that of the Laplace decomposition method, the authors combined the Laplace transforms and homotopy perturbation method to introduced Laplace homotopy perturbation method.

In this study, we use the Laplace homotopy perturbation method for finding the solution of the Burgers equation in 1. This method has also been used for solving various kinds of ordinary/fractional order differential equations [8–10, 14]. This method is called the homotopy perturbation transform method and combines the Laplace transform’s properties and the homotopy perturbation method [11, 14].

2 Basic definitions

In this section, we give some definitions and properties of fractional calculus (cf. [4, 5, 17]).

Definition 1. The left-sided Riemann-Liouville fractional integral of order $\mu \geq 0$ of a function $f, f \in C_\alpha, \alpha \geq -1$ is defined by

$$I^\mu f(t) = \begin{cases} \frac{1}{\Gamma(\mu)} \int_0^t \frac{f(\tau)}{(t-\tau)^{1-\mu}} d\tau & \mu > 0, t > 0, \\ f(t) & \mu = 0. \end{cases}$$

Definition 2. The left-sided Caputo fractional derivative of f , where $f \in C_{-1}^m$ and $m \in N \cup \{0\}$, is defined by

$$D_*^\mu f(t) = \frac{\partial^\mu f(t)}{\partial t^\mu} = \begin{cases} I^{m-\mu} \left[\frac{\partial^m f(t)}{\partial t^m} \right] & m - 1 < \mu < m, \\ \frac{\partial^m f(t)}{\partial t^m} & \mu = m. \end{cases} \quad m \in N,$$

Note that

- (i) $I_t^\mu f(x, t) = \frac{1}{\Gamma(\mu)} \int_0^t \frac{f(x, s)}{(t-s)^{1-\mu}} ds, \mu > 0, t > 0$
- (ii) $D_{*t}^\mu f(x, t) = I_t^{m-\mu} \frac{\partial^m f(x, t)}{\partial t^m}, m - 1 < \mu \leq m.$

Definition 3. The Laplace transform of $f(t)$ is given by

$$F(s) = \mathcal{L}[f(t)] = \int_0^\infty e^{-st} f(t) dt.$$

Definition 4. The Laplace transform of the Riemann-Liouville fractional integral is defined by

$$\mathcal{L}\{I^\mu f(t)\} = s^{-\mu} F(s).$$

Definition 5. The Laplace transform of the Caputo fractional derivative is defined by

$$\mathcal{L}\{D^\mu f(t)\} = s^\mu F(s) - \sum_{k=0}^{n-1} s^{(\mu-k-1)} f^{(k)}(0), \quad n - 1 < \mu < n.$$

3 Application of the Laplace homotopy perturbation method

In this section we use the Laplace homotopy perturbation method [11, 14] to solve a type of space-fractional Burgers equation and time-fractional Burgers equation.

3.1 The Laplace homotopy perturbation method for space-fractional Burgers equation

The purpose of this section is to discuss the use of Laplace transform algorithm and the homotopy perturbation method for solving space-fractional Burgers equation of the form

$$\frac{\partial u}{\partial t} + \epsilon u \frac{\partial u}{\partial x} = \nu \frac{\partial^2 u}{\partial x^2} - \eta \frac{\partial^\beta u}{\partial x^\beta} x > 0, \quad t > 0, \quad 0 < \beta \leq 1, \tag{2}$$

with the initial condition

$$u(0, t) = f(t), \quad u_x(0, t) = g(t).$$

First we explain the main idea of Laplace homotopy perturbation method. The method consists of applying Laplace transform in relation to the space on both sides of equation 2 so that

$$\mathcal{L} \left[\frac{\partial u}{\partial t} \right] + \epsilon \mathcal{L} \left[u \frac{\partial u}{\partial x} \right] - \nu \mathcal{L} \left[\frac{\partial^2 u}{\partial x^2} \right] + \eta \mathcal{L} \left[\frac{\partial^\beta u}{\partial x^\beta} \right] = 0.$$

Using the differential property of Laplace transform and the initial conditions we obtain

$$\begin{aligned} \frac{\partial \mathcal{L}[u(x, t)]}{\partial t} + \epsilon \mathcal{L} \left[u(x, t) \frac{\partial u(x, t)}{\partial x} \right] - \nu (s^2 \mathcal{L}[u(x, t)] \\ - su(0, t) - u_x(0, t)) \\ + \eta (s^\beta \mathcal{L}[u(x, t)] - s^{\beta-1} u(0, t)) = 0, \end{aligned}$$

$$\begin{aligned} \Rightarrow \mathcal{L}[u(x, t)] - s^{-1}f(t) - s^{-2}g(t) - \frac{\eta}{\nu} s^{\beta-2} \mathcal{L}[u(x, t)] \\ + \frac{\eta}{\nu} s^{\beta-3} f(t) - \frac{1}{\nu} s^{-2} \frac{\partial \mathcal{L}[u(x, t)]}{\partial t} \\ - \frac{\epsilon}{\nu} s^{-2} \mathcal{L}[u(x, t) \frac{\partial u(x, t)}{\partial x}] = 0. \end{aligned} \quad (3)$$

In the next stage, we construct a homotopy $V(r, p) : \Omega \times [0, 1] \rightarrow R$ using the homotopy perturbation technique which satisfies

$$\begin{aligned} H(V, p) = (1 - p) [\mathcal{L}[V(x, t)] - u_0(s, t)] + p [\mathcal{L}[V(x, t)] \\ - s^{-1}f(t) - s^{-2}g(t) - \frac{\eta}{\nu} s^{\beta-2} \mathcal{L}[V(x, t)] + \frac{\eta}{\nu} s^{\beta-3} f(t) \\ - \frac{1}{\nu} s^{-2} \frac{\partial \mathcal{L}[V(x, t)]}{\partial t} - \frac{\epsilon}{\nu} s^{-2} \mathcal{L} \left[V(x, t) \frac{\partial V(x, t)}{\partial x} \right]] \\ = 0, \end{aligned}$$

or

$$\begin{aligned} H(V, p) = \mathcal{L}[V(x, t)] - u_0(s, t) + p u_0(s, t) - p s^{-1}f(t) \\ - p s^{-2}g(t) - \frac{p \eta}{\nu} s^{\beta-2} \mathcal{L}[V(x, t)] + \frac{p \eta}{\nu} s^{\beta-3} f(t) \\ - \frac{p}{\nu} s^{-2} \frac{\partial \mathcal{L}[V(x, t)]}{\partial t} - \frac{p \epsilon}{\nu} s^{-2} \mathcal{L} \left[V(x, t) \frac{\partial V(x, t)}{\partial x} \right] \\ = 0, \end{aligned} \quad (4)$$

where $p \in [0, 1]$ is an embedding parameter and $u_0(s, t) = s^{-1}f(t) + s^{-2}g(t)$ is the initial approximation of equation 2 that satisfies the initial conditions. Obviously, if $p = 0$, equation 4 becomes

$$\mathcal{L}[V(x, t)] - u_0(s, t) = 0.$$

When $p = 1$, equation 4 is then the main equation under consideration equation 3. In topology, this deformation is called homotopic. Using the parameter p , we expand the solution in the form

$$\begin{aligned} V(x, t) = V_0(x, t) + pV_1(x, t) + p^2V_2(x, t) + p^3V_3(x, t) \\ + \dots \end{aligned} \quad (5)$$

Setting $p = 1$ results in the solution of equation 2,

$$u(x, t) = V_0(x, t) + V_1(x, t) + V_2(x, t) + V_3(x, t) + \dots$$

Substituting equation 5 into equation 4 and collecting the terms with the same power of p , we obtain

$$\begin{aligned} p^0 : \mathcal{L}[V_0(x, t)] - u_0(s, t) = 0, \\ \Rightarrow V_0(x, t) = \mathcal{L}^{-1}[u_0(s, t)] = \mathcal{L}^{-1}[s^{-1}f(t) + s^{-2}g(t)] \\ = f(t) + xg(t). \\ p^1 : \mathcal{L}[V_1(x, t)] + u_0(s, t) - s^{-1}f(t) - s^{-2}g(t) \\ - \frac{\eta}{\nu} s^{\beta-2} \mathcal{L}[V_0(x, t)] \end{aligned}$$

$$\begin{aligned} + \frac{\eta}{\nu} s^{\beta-3} f(t) - \frac{1}{\nu} s^{-2} \frac{\partial \mathcal{L}[V_0(x, t)]}{\partial t} \\ - \frac{\epsilon}{\nu} s^{-2} \mathcal{L} \left[V_0(x, t) \frac{\partial V_0(x, t)}{\partial x} \right] = 0, \\ \Rightarrow V_1(x, t) = \mathcal{L}^{-1}[-u_0(s, t) + s^{-1}f(t) + s^{-2}g(t)] \\ + \mathcal{L}^{-1} \left[\frac{\eta}{\nu} s^{\beta-2} \mathcal{L}[V_0(x, t)] \right] \\ - \mathcal{L}^{-1} \left[\frac{\eta}{\nu} s^{\beta-3} f(t) \right] + \mathcal{L}^{-1} \left[\frac{1}{\nu} s^{-2} \frac{\partial \mathcal{L}[V_0(x, t)]}{\partial t} \right] \\ + \mathcal{L}^{-1} \left[\frac{\epsilon}{\nu} \mathcal{L} \left[V_0(x, t) \frac{\partial V_0(x, t)}{\partial x} \right] \right]. \\ \vdots \end{aligned}$$

3.2 The Laplace homotopy perturbation method for time-fractional Burgers equation

Consider the following form of time-fractional Burgers equation

$$\frac{\partial^\alpha u}{\partial t^\alpha} + \epsilon u \frac{\partial u}{\partial x} = \nu \frac{\partial^2 u}{\partial x^2}, \quad t > 0, 0 < \alpha \leq 1, \quad (6)$$

with the initial condition

$$u(x, 0) = f(x).$$

The methodology consists of applying Laplace transform in relation to the time on both sides of equation 6,

$$\mathcal{L} \left[\frac{\partial^\alpha u}{\partial t^\alpha} \right] + \mathcal{L} \left[\epsilon u \frac{\partial u}{\partial x} \right] - \mathcal{L} \left[\nu \frac{\partial^2 u}{\partial x^2} \right] = 0.$$

Using the differential property of Laplace transform and initial condition we obtain

$$\begin{aligned} s^\alpha \mathcal{L}[u(x, t)] - s^{\alpha-1}f(x) + \epsilon \mathcal{L} \left[u(x, t) \frac{\partial u(x, t)}{\partial x} \right] \\ - \nu \frac{\partial^2 \mathcal{L}[u(x, t)]}{\partial x^2} = 0 \end{aligned}$$

or

$$\begin{aligned} \mathcal{L}[u(x, t)] - s^{-1}f(x) + \epsilon s^{-\alpha} \mathcal{L} \left[u(x, t) \frac{\partial u(x, t)}{\partial x} \right] \\ - \nu s^{-\alpha} \frac{\partial^2 \mathcal{L}[u(x, t)]}{\partial x^2} = 0. \end{aligned} \quad (7)$$

Using the homotopy perturbation technique, we construct a homotopy $V(r, p) : \Omega \times [0, 1] \rightarrow R$ which satisfies

$$\begin{aligned} H(V, p) = \mathcal{L}[V(x, t)] - u_0(x, s) + p u_0(x, s) - p s^{-1}f(x) \\ + p \epsilon s^{-\alpha} \mathcal{L}[V(x, t) \frac{\partial V(x, t)}{\partial x}] \\ - p \nu s^{-\alpha} \frac{\partial^2 \mathcal{L}[V(x, t)]}{\partial x^2} = 0. \end{aligned} \quad (8)$$

where $p \in [0, 1]$ is an embedding parameter and $u_0(x, s) = s^{-1}f(x)$ is the initial approximation of equation 6 that satisfies the initial conditions. Again, if $p = 0$, then equation 8 becomes

$$\mathcal{L}[V(x, t)] - u_0(x, s) = 0,$$

and when $p = 1$, equation 8 is again the main equation under consideration, namely equation 7. Substituting equation 5 into equation 8 and collecting the terms with the same power of p , we obtain

$$\begin{aligned} p^0 : \mathcal{L}[V_0(x, t)] - u_0(x, s) &= 0, \\ \Rightarrow V_0(x, t) &= \mathcal{L}^{-1}[u_0(x, s)] = \mathcal{L}^{-1}[s^{-1}f(x)] = f(x). \\ p^1 : \mathcal{L}[V_1(x, t)] + u_0(x, s) - s^{-1}f(x) \\ &+ \epsilon s^{-\alpha} \mathcal{L} \left[V_0(x, t) \frac{\partial V_0(x, t)}{\partial x} \right] \\ &- \nu s^{-\alpha} \frac{\partial^2 \mathcal{L}[V_0(x, t)]}{\partial x^2} = 0, \\ \Rightarrow V_1(x, t) &= \mathcal{L}^{-1}[-u_0(x, s) + s^{-1}f(x)] \\ &- \mathcal{L}^{-1} \left[\epsilon s^{-\alpha} \mathcal{L} \left[V_0(x, t) \frac{\partial V_0(x, t)}{\partial x} \right] \right] \\ &+ \mathcal{L}^{-1} \left[\nu s^{-\alpha} \frac{\partial^2 \mathcal{L}[V_0(x, t)]}{\partial x^2} \right]. \\ &\vdots \end{aligned}$$

4 Illustrative examples

For purposes of the illustration of Laplace homotopy perturbation method for solving Burgers equation of fractional order, we present two examples. In the first example, we consider a space-fractional Burgers equation, while in the second example, we consider a time-fractional Burgers equation.

Example 1. Consider the space-fractional Burgers equation given in [15] by

$$\frac{\partial u}{\partial t} + u \frac{\partial u}{\partial x} = \nu \frac{\partial^2 u}{\partial x^2} - \eta \frac{\partial^\beta u}{\partial x^\beta} \quad x > 0, \quad t > 0, \quad 0 < \beta \leq 1, \quad (9)$$

with the initial condition

$$\begin{aligned} u(0, t) &= 0, \quad u_x(0, t) = \frac{1}{t} - \frac{\pi^2}{2\nu t^2}, \\ u(x, 1) &= x - \pi \tanh \left[\frac{\pi x}{2\nu} \right]. \end{aligned}$$

The exact solution, for the special case $\eta = 0$ is given by

$$u(x, t) = \frac{x}{t} - \frac{\pi}{t} \tanh \left[\frac{\pi x}{2\nu t} \right].$$

Using equation 6 and the initial conditions, we can obtain the approximations

$$\begin{aligned} V_0(x, t) &= x \left(\frac{1}{t} - \frac{\pi^2}{2\nu t^2} \right), \\ V_1(x, t) &= \frac{\pi^4 x^3}{24 t^4 \nu^3} + \frac{x^{3-\beta} \eta}{\Gamma[4-\beta]} \left(\frac{1}{t} - \frac{\pi^2}{2\nu t^2} \right), \\ V_2(x, t) &= -\frac{\pi^6 x^5}{240 t^6 \nu^5} + \frac{\pi^4 x^{5-\beta} \eta}{t^4 \nu^4 \Gamma[6-\beta]} - \frac{\pi^4 x^{5-\beta} \beta \eta}{4 t^4 \nu^4 \Gamma[6-\beta]} \\ &- \frac{3 \pi^2 x^{5-\beta} \eta}{t^3 \nu^3 \Gamma[6-\beta]} + \frac{\pi^2 x^{5-\beta} \beta \eta}{t^3 \nu^3 \Gamma[6-\beta]} + \frac{3 x^{5-\beta} \eta}{t^2 \nu^2 \Gamma[6-\beta]} \\ &- \frac{x^{5-\beta} \beta \eta}{t^2 \nu^2 \Gamma[6-\beta]} + \\ &\frac{x^{5-2\beta} \eta (\pi^4 x^\beta \Gamma[6-2\beta] + 2 t^2 \eta \nu (-\pi^2 + 2 t \nu) \Gamma[6-\beta])}{4 t^4 \nu^4 \Gamma[6-2\beta] \Gamma[6-\beta]}, \\ &\vdots \end{aligned}$$

The solution in series form is given by

$$\begin{aligned} u(x, t) &= x \left(\frac{1}{t} - \frac{\pi^2}{2\nu t^2} \right) + \frac{\pi^4 x^3}{24 t^4 \nu^3} - \frac{\pi^6 x^5}{240 t^6 \nu^5} \\ &+ \frac{x^{3-\beta} \eta}{\Gamma[4-\beta]} \left(\frac{1}{t} - \frac{\pi^2}{2\nu t^2} \right) + \frac{\pi^4 x^{5-\beta} \eta}{t^4 \nu^4 \Gamma[6-\beta]} \\ &- \frac{\pi^4 x^{5-\beta} \beta \eta}{4 t^4 \nu^4 \Gamma[6-\beta]} - \frac{3 \pi^2 x^{5-\beta} \eta}{t^3 \nu^3 \Gamma[6-\beta]} + \frac{\pi^2 x^{5-\beta} \beta \eta}{t^3 \nu^3 \Gamma[6-\beta]} \\ &\vdots \end{aligned} \tag{10}$$

Setting $\beta = \frac{1}{2}$ in equation 10, we reproduce the solution given in [2] by

$$\begin{aligned} u(x, t) &= x \left(\frac{1}{t} - \frac{\pi^2}{2\nu t^2} \right) + \frac{\pi^4 x^3}{24 t^4 \nu^3} - \frac{\pi^6 x^5}{240 t^6 \nu^5} + \frac{8 x^{5/2} \eta}{15 \sqrt{\pi} t \nu} \\ &+ \dots \end{aligned}$$

Also, we obtain the exact solution when $\eta = 0$ in equation 10 with

$$u(x, t) = x \left(\frac{1}{t} - \frac{\pi^2}{2\nu t^2} \right) + \frac{\pi^4 x^3}{24 t^4 \nu^3} - \frac{\pi^6 x^5}{240 t^6 \nu^5} + \dots$$

We observe that the results obtained by this method are exactly same as the solution given in [15] which uses the Adomian decomposition method.

Example 2. Consider the time-fractional Burgers equation given in [15] by

$$\frac{\partial^\alpha u}{\partial t^\alpha} + u \frac{\partial u}{\partial x} = \nu \frac{\partial^2 u}{\partial x^2} \quad t > 0, \quad 0 < \alpha \leq 1,$$

with the initial condition

$$u(x, 0) = f(x) = \frac{\mu + \sigma + (\sigma - \mu) \exp(\frac{\mu}{\nu}(x - \lambda))}{1 + \exp(\frac{\mu}{\nu}(x - \lambda))}.$$

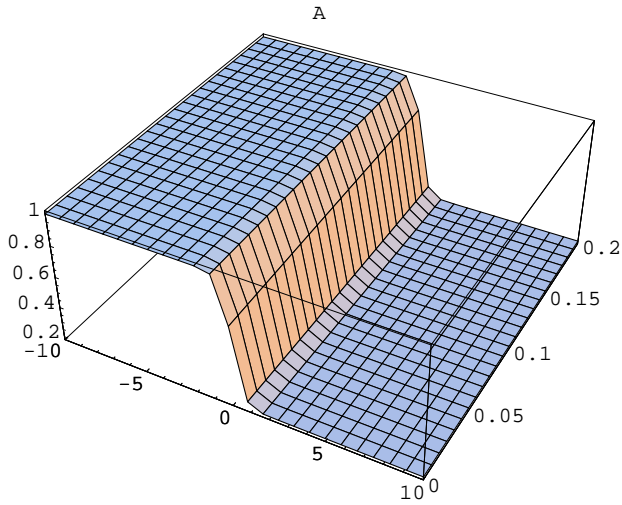

Figure 1: The approximate solution (A).

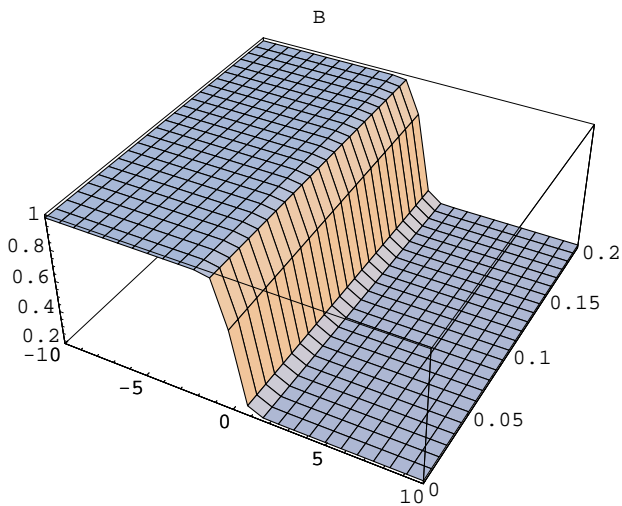

Figure 2: The exact solution (B).

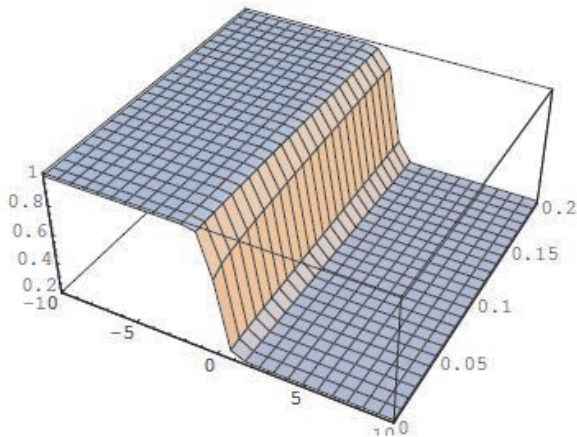

Figure 3: The approximate solution for $\alpha = \frac{1}{2}$ (C).

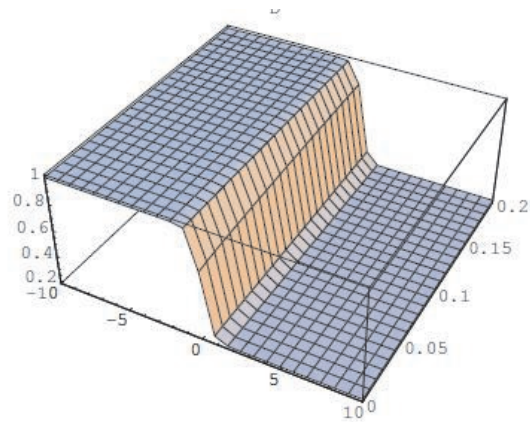

Figure 4: The approximate solution for $\alpha = \frac{3}{4}$ (D).

The exact solution for the special case $\alpha = 1$ is given by

$$u(x, t) = \frac{\mu + \sigma + (\sigma - \mu) \exp\left(\frac{\mu}{\nu}(x - \sigma t - \lambda)\right)}{1 + \exp\left(\frac{\mu}{\nu}(x - \sigma t - \lambda)\right)}. \quad (11)$$

Using equation 9 and the initial conditions, we can obtain the approximations

$$\begin{aligned} V_0(x, t) &= f(x), \\ V_1(x, t) &= (\nu f^{(2)}(x) - f(x)f'(x)) \frac{t^\alpha}{\Gamma[\alpha + 1]}, \\ V_2(x, t) &= (2f(x)(f'(x))^2 + (f(x))^2 f^{(2)}(x) - 4\nu f'(x)f^{(2)}(x) \\ &\quad - 2\nu f'(x)f^{(3)}(x) + \nu^2 f^{(4)}(x)) \frac{t^{2\alpha}}{\Gamma[2\alpha + 1]}, \\ &\vdots \end{aligned}$$

The solution in series form is given by

$$\begin{aligned} u(x, t) &= f(x) + (\nu f^{(2)}(x) - f(x)f'(x)) \frac{t^\alpha}{\Gamma[\alpha + 1]} \\ &\quad + (2f(x)(f'(x))^2 + (f(x))^2 f^{(2)}(x) - 4\nu f'(x)f^{(2)}(x) \\ &\quad - 2\nu f'(x)f^{(3)}(x) + \nu^2 f^{(4)}(x)) \times \frac{t^{2\alpha}}{\Gamma[2\alpha + 1]} \\ &\quad + \dots \end{aligned} \quad (12)$$

The results for the exact solution equation 11 and the approximate solution equation 12 for the special case $\alpha = 1$ are shown in Figures 1 and 2. It can be seen from Figure 1 that the solution obtained by the present method is nearly identical to the exact solution. Figures 3 and 4 show the approximate solutions when $\alpha = \frac{1}{2}$ and $\alpha = \frac{3}{4}$ respectively. The parameters have the values $\nu = 0.1, \mu = 0.4, \sigma = 0.6, \lambda = 0.125$. From the graphical results in Figures 3 and 4, we may also conclude that the approximate solution obtained using the Laplace homotopy perturbation method is in agreement with the approximate solution obtained using the variational iteration method [16] and Adomian decomposition method [15] for all values of x and t .

5 Conclusion

The Laplace homotopy perturbation method is a powerful method for handling linear and nonlinear fractional partial differential equations. This method has been successfully applied to fractional space and time Burgers equations. This technique produces the same solution as the Adomian decomposition method with the proper choice of initial approximation.

Conflict of interest: The authors declare that there is no conflict of interests regarding the publication of this paper.

References

- [1] Biler P., Funaki T., Woźniński W.A., Fractal Burgers equation, *J. Differential Eq.*, 1998, 148, 9–46.
- [2] El-Shahed M., Adomian decomposition method for solving Burgers equation with fractional derivative, *J. Frac. Cal.*, 2003, 24, 23–28.
- [3] Guesmia A., Daili N., Numerical approximation of fractional Burgers equation, *J. Comm in Math and Appl.*, 2010, 2, 77–90.
- [4] Baleanu D., Diethelm K., Scalas E., Trujillo J.J., *Fractional Calculus: Models and Numerical Methods*, (Series on Complexity, Nonlinearity and Chaos), World Scientific, Hackensack, 2012.
- [5] Jafari H., *An Introduction to Fractional Differential Equations*, Mazandaran University Press, 2013, (in Persian).
- [6] Jafari H., Daftardar-Gejji V., Solving linear and nonlinear fractional diffusion and wave equations by Adomian decomposition, *J. Appl. Math. Comput.*, 2006, 180, 488–497.
- [7] Jafari H., Momani S., Solving fractional diffusion and wave equations by modified homotopy perturbation method, *J. Physics Letters A*, 2007, 370, 388–396.
- [8] Jafari H., Khalique C.M., Nazari M., Application of the Laplace decomposition method for solving linear and nonlinear fractional diffusion–wave equations, *Appl. Math. Lett.*, 2011, 24(11), 1799–1805.
- [9] Jafari H., Numerical Solution of Time-Fractional Klein–Gordon Equation by Using the Decomposition Methods, *Journal of Computational and Nonlinear Dynamics*, 2016, 11(4), 041015.
- [10] Khan Y., Vazquez-Leal H., Faraz N., An auxiliary parameter method using Adomian polynomials and Laplace transformation for nonlinear differential equations, *Applied Mathematical Modelling*, 2013, 37, 2702–2708.
- [11] Khan Y., Wu Q., Homotopy Perturbation Transform Method for nonlinear equations using He's Polynomials, *Computers and Mathematics with Applications*, 2011, 61, 1963–1967.
- [12] Khuri S.A., A Laplace decomposition algorithm applied to class of nonlinear differential equations, *J. Math. Appl.*, 2001, 141–155.
- [13] Khuri S.A., A new approach to Bratu's problem, *J. Appl. Math. Comput.*, 2004, 147, 131–136.
- [14] Kumar S., Kocak H., and Yildirim A., A fractional model of gas dynamics equation by using Laplace transform, *Z. Naturforsch.*, 2012, 67, 389–96.
- [15] Momani S., Non-perturbative analytical solutions of the space- and time-fractional Burgers equations, *J. Chaos, Solitons and Fractals*, 2006, 28, 930–937.
- [16] Odibat Z., Momani S., Alawneh A., Approximate analytical solution of the space- and time- fractional Burgers equations, *J. Européen des Systèmes Automatisés*, 2008, 6, 627–638.
- [17] Podlubny I., *Fractional differential equations*, Academic Press, San Diego, 1999.
- [18] Samko S.G., Kilbas A.A., Marichev O.I., *Fractional Integrals and Derivatives: Theory and Applications*. Gordon and Breach, Yverdon (1993).
- [19] El-Shahed M., Adomian decomposition method for solving Burgers equation with fractional derivative, *J. Frac. Cal.*, 2003, 24, 23–28.
- [20] Sugimoto N., Burgers equation with a fractional derivative; Hereditary effects on non-linear acoustic waves, *J. Fluid Mech.*, 1991, 225, 631–653.
- [21] Yang Y.J., Baleanu D., and Yang X.J., A Local Fractional Variational Iteration Method for Laplace Equation within Local Fractional Operators, *Abstract and Applied Analysis*, 2013, 1–6, Article ID 202650.
- [22] Yang X.J., Srivastava H.M., Cattani C., Local fractional homotopy perturbation method for solving fractal partial differential equations arising in mathematical physics, *Romanian Rep. Phys.*, 2015, 67(3), 752–761.