



**JOINT SOURCE CHANNEL CODING USING TRELIS CODED  
QUANTIZATION**

**SAMIR H. SALIH AL-SAMMARRIE**

**FEBRUARY 2015**

**JOINT SOURCE CHANNEL CODING USING TRELIS CODED  
QUANTIZATION**

**A THESIS SUBMITTED TO  
THE GRADUATE SCHOOL OF NATURAL AND APPLIED  
SCIENCES OF  
ÇANKAYA UNIVERSITY**

**BY  
SAMIR H. SALIH AL-SAMMARRIE**

**IN PARTIAL FULFILLMENT OF THE REQUIREMENTS FOR THE  
DEGREE OF  
MASTER OF SCIENCE  
IN  
THE DEPARTMENT OF  
ELECTRONIC AND COMMUNICATION ENGINEERING**

**FEBRUARY 2015**

Title of the Thesis : **Joint Source Channel Coding Using Trellis Coded Quantization**

Submitted by **Samir H. Salih AL-SAMMARRIE**

Approval of the Graduate School of Natural and Applied Sciences, Çankaya University.

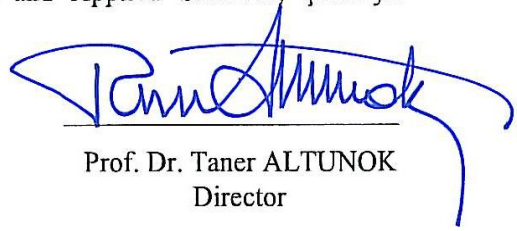

Prof. Dr. Taner ALTUNOK  
Director

I certify that this thesis satisfies all the requirements as a thesis for the degree of Master of Science.



Prof. Dr. Halil T. EYYUBOĞLU  
Head of Department

This is to certify that we have read this thesis and that in our opinion it is fully adequate, in scope and quality, as a thesis for the degree of Master of Science.

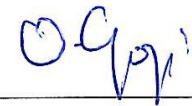

Assoc. Prof. Dr. Orhan GAZI  
Supervisor

**Examination Date: 05.02.2015**

**Examining Committee Members :**

Assoc. Prof. Dr. Orhan GAZI (Çankaya Univ.)

Assoc. Prof. Dr. Fahd JARAD (THK Univ.)

Assist. Prof. Dr. Göker ŞENER (Çankaya Univ.)

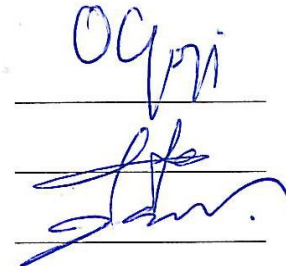

## STATEMENT OF NON PLAGIARISM PAGE

I hereby declare that all information in this document has been obtained and presented in accordance with academic rules and ethical conduct. I also declare that, as required by these rules and conduct, I have fully cited and referenced all material and results that are not original to this work.

Name, Last Name: Samir H. Salih, AL-SAMMARRIE

Signature : 

Date : 05.02.2015

## ABSTRACT

### JOINT SOURCE CHANNEL CODING USING TRELIS CODED QUANTIZATION

AL-SAMMARRIE, Samir H. Salih

M.Sc., Department of Electronic and Communication Engineering

Supervisor: Assoc. Prof. Dr. Orhan GAZI

February 2015, 38 pages

Trellis coded quantization is inspired from trellis coded modulation for better bit efficient quantizer design. In this thesis study we proposed joint communication systems, involving trellis coded quantization, space time block codes, and recursive systematic convolutional codes. The proposed joint communication structures are novel and they are iteratively processable. Using the  $RSC(1,5/7)_{\text{octal}}$  state transition diagram we proposed a new trellis coded quantization approach and integrated the proposed structure with space time block codes and the performance of the joint system is obtained via computer simulation. From simulation results it is seen that the proposed system shows better performance than the classical TCQ integrated with space time block codes and in addition the proposed system has lower distortion when compared to its classical counterparts.

**Keywords:** Trellis Coded Quantization, Viterbi Algorithm, MAP Algorithm, Iterative Decoding, Concatenated Codes and Alamouti Code.

## ÖZ

### KAFES KODLAMALI NİCEMLEME KULLANILARAK BİRLEŞİK KAYNAK VE KANAL KODLAMA

AL-SAMMARRIE, Samir H. Salih

Yüksek Lisans, Elektronik ve Haberleşme Mühendisliği Anabilim Dalı

Tez Yöneticisi: Doç. Dr. Orhan GAZİ

Şubat 2015, 38 sayfa

Kafes kodlamalı nicemleme yöntemi kafes kodlamalı modülasyon yönteminden ilham alınarak geliştirilmiş olan bir nicemleme tekniğidir. Bu tez çalışmasında yeni birleşik iletişim üniteleri öneriyoruz. Önerilen birleşik ünitelerde kafes kodlamalı nicemleme, uzay zaman blok kodları, özyinelemeli konvolusyonel kodlar içermektedir. Önerilen sistemler orijinaldirler ve yinelemeli çözüme uygun yapıdadırlar. Ayrıca  $RSC(1,5/7)_{\text{octal}}$  konvolusyonel kodunun durum grafiğini kullanarak yeni bir kafes kodlamalı nicemleme yöntemi önerdik. Önerilen sistem uzay zaman blok kodları ile birleştirilerek klasik kafes kodlamalı nicemleme sisteminin uzay zaman kodları ile birleştirilmesinden elde edilen sistemin performansından daha iyi performans gösteren bir sistem elde edilmiştir. Performans ölçümleri, bit hata oranı, çerçeve hata oranı ve bozulma miktarı kriterleri göz önüne alınarak yapılmaktadır.

**Anahtar Kelimeler:** Kafes Kodlamalı Nicemleme, Viterbi Algoritması, MAP Algoritması, Yinelemeli Çözüm, Birleşik Kodlar, Alamouti Kodu

## **ACKNOWLEDGEMENTS**

I would like to thank all the former and present colleagues and friends at the Department of Electronic and Communication Engineering for the contribution of the nice and friendly atmosphere here. Specially, I would like to express my deepest gratitude to my research supervisor Assoc Prof. Dr. Orhan GAZI for providing me with the opportunity to do this interesting work and giving me invaluable expertise throughout the work. His inspiring guidance, deep knowledge and patience have been invaluable for me and very much appreciated.

Last but not least, I would like to express my most sincere gratitude and respect to my family for the help and spiritual encouragement, and for their patience, sacrifice and understanding. Without their help it would not have been possible to complete the thesis.

Many thanks also go to my other friends, thanks all of you for your friendship.

## TABLE OF CONTENTS

STATEMENT OF NON PLAGIARISM.....	iii
ABSTRACT.....	iv
ÖZ.....	v
ACKNOWLEDGEMENTS.....	vi
TABLE OF CONTENTS.....	vii
LIST OF FIGURES.....	ix
LIST OF TABLES.....	xi
LIST OF ABBREVIATIONS.....	xii

### CHAPTERS:

<b>1. INTRODUCTION.....</b>	<b>1</b>
<b>1.1. MIMO for Wireless Networks.....</b>	<b>3</b>
<b>1.2. Background and Motivation.....</b>	<b>6</b>
<b>1.3. Thesis Organization.....</b>	<b>7</b>
<b>2. LITERATURE REVIEW.....</b>	<b>8</b>
<b>2.1. Trellis Coded Quantization (TCQ).....</b>	<b>8</b>
<b>2.1.1. A numerical example for a 4-state TCQ.....</b>	<b>11</b>
<b>2.2. Recursive Systematic Convolutional Code (RSC).....</b>	<b>14</b>
<b>2.3. MAP algorithm.....</b>	<b>15</b>
<b>2.4. Semi-random Interleaver (S-R Interleaver) .....</b>	<b>17</b>
<b>2.5. Space-Time Block Codes (STBC).....</b>	<b>16</b>
<b>2.5.1. Alamouti scheme.....</b>	<b>19</b>
<b>3. JOINT TRELIS CODED QUANTIZATION WITH SPACE TIME BLOCK CODING.....</b>	<b>25</b>
<b>3.1. Classical System Strategy.....</b>	<b>25</b>



3.2. Triple Component System Structure (TCQ-RSC-STBC).....	28
3.3. Dual Component System Structure (TCQ-STBC Iterative System).....	31
4. CONCLUSION AND FUTURE WORK.....	37
REFERENCES.....	R1
APPENDICES.....	A1
A. CURRICULUM VITAE.....	A1

## LIST OF FIGURES

### FIGURES

<b>Figure 1</b>	Multiple input multiple output (MIMO) system.....	4
<b>Figure 2</b>	(a) A 4-state trellis with subset labeling, (b) Codebook partitioning for 2 bits/sample TCQ.....	9
<b>Figure 3</b>	(a) Symbolic representation of a TCQ, where $X$ is the input vector and $Q(X)$ , the quantized vector, (b) The format of the output of TCQ.....	11
<b>Figure 4</b>	Partitioning of the scalar quantizer into four sub-quantizers, for trellis coding at a rate of 2 bits/sample.....	13
<b>Figure 5</b>	An example of a 4-state trellis indicating the distortions at each node and the best path through the trellis.....	13
<b>Figure 6</b>	Non-Systematic convolutional encoder with $r=1/2$ .....	14
<b>Figure 7</b>	The RSC encoder structure, $r=1/2$ and $K=3$ .....	15
<b>Figure 8</b>	Alamouti space-time encoder and decoder for 2-Tx and 1-Rx...	21
<b>Figure 9</b>	Fading coefficients distribution for 2-Tx and 2-Rx.....	22
<b>Figure 10</b>	Alamouti space-time encoder and decoder for 2-Tx and 2-Rx...	24
<b>Figure 11</b>	Encoder and decoder forms for <i>Classical System</i> , $L$ frame length.....	26
<b>Figure 12</b>	<i>Classical System</i> Bit Error Rate (BER) and Frame Error Rate (FER) results.....	27
<b>Figure 13</b>	<i>Classical System</i> distortion results.....	28
<b>Figure 14</b>	Encoder and decoder forms for <i>Triple Component System</i> , $L$ frame length.....	29

## FIGURES

<b>Figure 15</b>	<i>Triple Component System</i> Bit Error Rate (BER) results.....	30
<b>Figure 16</b>	<i>Triple Component System</i> Frame Error Rate (FER) results.....	30
<b>Figure 17</b>	<i>Triple Component System</i> distortion results.....	31
<b>Figure 18</b>	Encoder and decoder forms for <i>Dual Component System</i> , $L$ frame length.....	33
<b>Figure 19</b>	<i>Dual Component System</i> (a) A 4-state trellis with subset labeling, (b) Codebook partitioning for 2 bits/sample TCQ.....	33
<b>Figure 20</b>	<i>Dual Component System</i> Bit Error Rate (BER) results.....	34
<b>Figure 21</b>	<i>Dual Component System</i> Frame Error Rate (FER) results.....	34
<b>Figure 22</b>	<i>Dual Component System</i> distortion results.....	35

## LIST OF TABLES

### TABLES

<b>Table 1</b>	Distortion of Paths in Each Stage.....	12
<b>Table 2</b>	Comparisons Among <i>Classical System, Triple Components System</i> and <i>Dual Components System</i> .....	36

## LIST OF ABBREVIATIONS

ECC	Error Control Coding
SNR	Signal to Noise Ratio
MAP	Maximum A Posteriori
BW	Band Width
AWGN	Additive White Gaussian Noise
APP	A Posteriori Probability
LLR	Long-Likelihood Ratio
RSC	Recursive Systematic Convolutional
4-PSK	4 Phase Shift Key
MIMO	Multiple Input Multiple Output
SPK	Single Parity Check
SISO	Soft Input Soft Output
CSI	Channel State Information
MMSE	Minimum Mean Square Error
ML	Maximum Likelihood
STBC	Space Time Block Coding
BER	Bit Error Rate
FER	Frame Error Rate

## **CHAPTER 1**

### **INTRODUCTION**

TCQ is shown to be powerful method for signal quantization especially in image compression algorithm. To support arising image communication applications like digital libraries teleconferencing and remote sensing, the ability to decode the compressed image is a critical issue. It is well known that trellis source coding asymptotically achieves the bounds of Shannon theory at the price of constructing (and storing) huge codebooks of random reproduction values. More feasible trellis codes are instead obtained by reducing and structuring the codebooks. Trellis coded quantization (TCQ) represents a successful attempt in this direction.

Quantization is used to produce digital stream (or description) for an analog signal. And the digital stream is transmitted and at the receiver side digital stream is used to create an approximated replica of analog signal. The compression efficiency of a quantizer is a measured by its rate, which is the average number of bits per source sample produced by the quantizer, and its average distortion included by substituting the replica for the original signal. Other important parameters for assisting the performance of the quntizer include the coding delay and the complexity of implementing its encoded and decoder.

It is well known that trellis source coding asymptotically achieves the bounds of Shannon theory at the price of constructing (and storing) huge codebooks of random reproduction values [1]. More feasible trellis codes are instead obtained by reducing the number of codewords. Trellis coded quantization (TCQ) represents a successful

attempt in this direction [2]. TCQ has first appeared as a natural counterpart, in the source-coding framework, of trellis-coded modulation [3]. The basic TCQ scheme uses an extended codebook of  $2^{R+1}$  reproduction values to code a source at a rate of  $R$  bit/sample. This codebook is divided into four sub-codebooks that are assigned to the branches of a trellis diagram by means of a rate  $\frac{1}{2}$  binary convolutional code, and the Viterbi algorithm is developed and applied to detect the minimum mean-squared-error path over the trellis. Among the others, TCQ and TCQ-like coding ([4], [5]) have found application in image coding [6], [7], in scalable coding [8] and in multiple description coding [9]. Since the choice of the actual reproduction values is responsible for the achievable performance [10], several algorithms have been proposed to find the best codebook. For instance, in the original paper [2] an iterative algorithm is given for alphabet optimization that improves on the uniform distribution. In other approaches, in an attempt to achieve some of the boundary gain too [11], the occurrences of each reconstruction level are taken into account during the optimization (and the coding) procedure. Examples are given in [12] (that refines the work in [13]) and in [14], where the concept is more elegantly approached via Lagrangian optimization. Observing that the size of the reproduction alphabet puts (at rates close to  $\log_2|A|$ , with  $|A|$  the size of the alphabet) a non-negligible limit on the achievable rate distortion performance  $L$ . Cappellari is with the Dept. of Information Engineering of the University of Padova, Italy. [15], recent approaches [16], [17] have investigated the opportunity to use larger codebooks for improved performance. In particular, in [17] a linear congruential recursion is used to randomize with a very small computational burden the labels associated with the trellis branches.

The performance improvement over the basic TCQ systems was eventually obtained by taking into account for the rate (i.e. by entropy coding) or by increasing the reproduction set, but essentially keeping the trellis structure of a convolutional binary code for code-word randomization. As observed in [17], in fact, there seems to be no performance gain from changing the very simple shift-register transitions. Despite the fact that eventually TCQ heavily relies on convolutional codes, the current know-

how about the algebraic properties of the convolutional codes has not been considered for the design of TCQ systems, which are instead based on ad-hoc convolutional codes (such as the ones in [3]).

### **1.1. MIMO for Wireless Networks**

Digital communication is used multiple-input–multiple output (MIMO), also known as “volume-to-volume”. Wireless communication is raised as one of the most important technical advance in recent development in communication fields. This technology, clearly is the significant development and takes the top on the list of twenty-first-century technical advances with the ability of fixing the issue of traffic capacity in the new coming years Internet-intensive wireless networks. Just a few years after its invention, this technology is very interesting and looks like prepared through large-scale standards-driven commercial wireless products and networks like third-generation (3G) networks, wireless local area networks (WLAN), broadband wireless access systems and beyond.

MIMO systems are introduced as: Given a random wireless communication system, it is considered a link in which the transporting part and also the receiving part is supplied with multiple antennas as explained in Fig. 1. The idea beyond MIMO is that the signals on the transmit (TX) antenna elements at one side and the receive (RX) antenna elements at another side are combined in such a method that the signal quality such as the data rate (bits/sec) or bit-error rate (BER) of the wireless communication for each MIMO system will be increased. This advantage possible to be used and to be increased both the operator’s revenues significantly and the network’s quality of service.



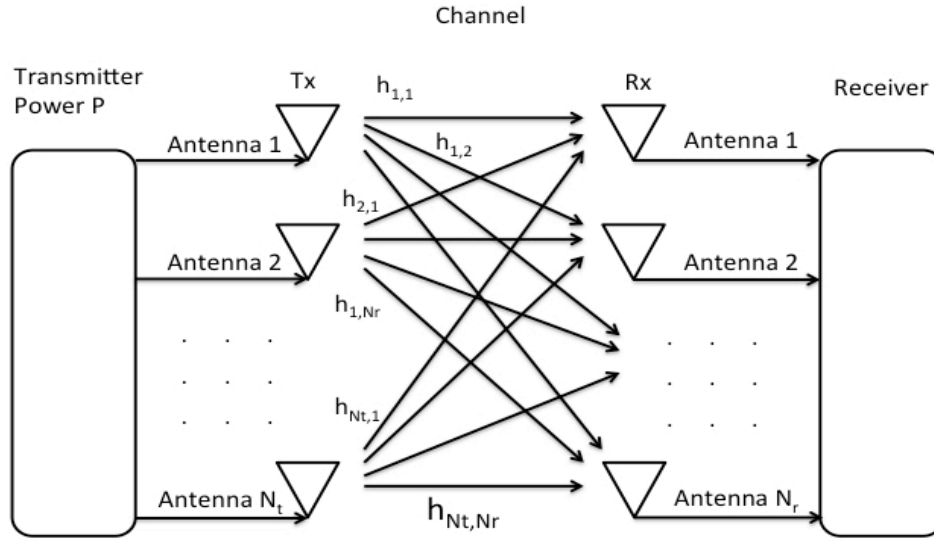

**Figure 1** Multiple input multiple output (MIMO) system

The main idea in MIMO [18] communication systems lies on the use of multiplexing such that multi antennas are employed during communication. Such as MIMO systems are shown as an up-date and known as smart antennas, a famous technology is used array of antennas for increasing wireless data transporting since many years ago. It is interesting to observe that every antenna element on a MIMO system works and has the same frequency in this case the MIMO system does not need more bandwidth. Moreover, the comparison can be shown; the total power which is used through all the transmit antennas, is equal or less than the system that has single antenna. i.e.,

$$P_T \leq \sum_{K=1}^N P_k \quad (1.1)$$

where  $P_T$  is the total MIMO system power, the total antennas' number is  $N$  at the sender site, the power allocated through the  $k_{th}$  antenna element is  $P_k$ , and the power if the system has a single antenna element is  $P$ . Furthermore, the MIMO system expend no extra power as explain and shown in the equation (1.1) the reason beyond this advantage is return to the fact that the system has multiple antenna elements.

Wireless developers continuously looking for improve the link reliability, coverage of wireless networks, and spectrum efficiency/capacity. One of the technologies which is used multiple antenna elements over the suitable signalling and receiver techniques is Space-time wireless technology, shows a significant and powerful technique for raising wireless system performance. Another advanced for MIMO techniques are suggested for the following years mobile networks in wireless Wide Area Network (WANs) and Local Area Network (LANs). Multiple antenna elements when implemented with suitable Space-Time Coding (STC) techniques can be made and reached a powerful performance in multipath Rayleigh fading channels. The Space Time-Coding (STC) is developed as a most important research area in wireless communication fields.

In the latest few years, Space-Time Block Coding (STBC) is applied in mobile network systems which the goal is to send true multimedia capability. This thesis presents the Space-Time Block Codes (STBC) for wireless communications which consist of multiple antenna elements at both transmitter site and receiver site. Moreover, the Alamouti scheme is a special type of Space-Time Block Codes (STBC).

At any rate, wireless communication is the fastest rising portion of the communication fields. For example, wireless communication is taken the interesting of the entire world and the peoples' imagination. Over the last several years, cellular systems gain experience which is exponential development. In most development countries, the business of cellular mobile has become a part of everyday life. And wireless communication has quickly added to the antiquated wireline networks in several development countries. Moreover, wireless local area networks (W-LANs) actually replace or upgrade wired systems in many factories, companies, and homes. Several new applications are developed. Such as, automated highways and factories, smart homes and appliances, wireless sensor networks, and remote telemedicine, are came from the ideas of researchers to support the systems. The significant development of wireless networks connected with the reproduction of laptop and

desktop computers point to a brilliant future for wireless systems, both as part of the larger communication infrastructure and as stand-alone networks. But, several technical challenges still in development strong wireless systems that transport the data to support arising the performance of applications.

In the latest decades, scientists have discovered that several advantages as well as essential amount of performance obtaining from receive diversity possible to be reproduced by using multiple antenna elements at transmitter to have transmitted diversity. In the early 1990's, the researchers have begins developments of transmit diversity techniques. Since then the concern in this field has raised in a fast fashion.

## **1.2. Background and Motivation**

In this thesis, a relatively new quantization technique known as trellis coded quantization (TCQ) is studied. A very brief description of it is provided here but a more detailed description can be found in Chapter 2. Trellis coded quantization owes its existence to its vastly popular dual, trellis coded modulation (TCM), developed in the late 1980s by Ungerboeck [19] [20]. Though the TCQ scheme has not made such a dent in commercial products so far, that day is certainly not far off, because of its power and versatility. The beauty of the TCQ lies in the fact that it is able to deliver some of the punch of a vector quantizer (VQ) while retaining only a fraction of a VQ's complexity. The TCQ was a major motivating factor behind this thesis. The aim of this work is to explore the connection between of TCQ and STBC, review the system behaviour and to improve the system performance.

### **1.3. Thesis Organization**

This thesis contains of four Chapters. All the important information about Trellis Coded Quantization (TCQ), Space Time Block Coding (STBC), some methods are applied in channel coding to detect and correct the errors, and numerical analysis of these fields can be founded for different geometries.

Chapter 1 is an introduction, a brief review on fundamental research work of trellis-coded quantization, basic background on Multi Input Multi Output (MIMO).

Chapter 2 describes and shows the equation and structures for that, numerical example for TCQ and two cases in STBC each case have different number of antennas.

In Chapter 3, TCQ and STBC are joined together in one system and we proposed some new forms to increase the system performance and present the results Bit Error Rate (BER), Frame Error Rate (FER) and the system distortions.

Chapter 4 includes the Conclusion part and Future works.

## CHAPTER 2

### LITERATURE REVIEW

#### 2.1. Trellis Coded Quantization (TCQ)

Trellis coded quantization (TCQ) is vector quantization. Its popularity can be attributed to its superior performance and its low complexity compared to conventional VQ's. It has been shown in [21] that for memoryless uniform sources, TCQ is capable of extracting all of the cell shape gain, i.e., 1.53 dB, as  $R$  becomes asymptotically large. In simple terms, TCQ's superior performance can be explained by thinking of it as placing the quantizer output points optimally in an  $n$ -dimensional hypercube, i.e., the points are placed maximally apart. The motivation for TCQ is derived from Ungerboeck's formulation for trellis coded modulation (TCM) [19] [20]. In the easy way, a memoryless TCQ source is used for encoding the data at rate of  $R$  bits/sample,  $2^{R+1}$  elements is a scalar quantizer codebook which is divided into four subsets, i.e., sub-quantizers, every containing  $2^{R-1}$  elements. The previous subsets are applied to label the branches of an appropriately selected trellis structures. Figure 2 is shown an example of a 4 states trellis with compatible codebook and partition (for  $R = 2$  bits/sample). The scalar codebook chosen can either be uniform or pdf-optimized (Lloyd-Max). The partitioning resorted to is the same in either case.

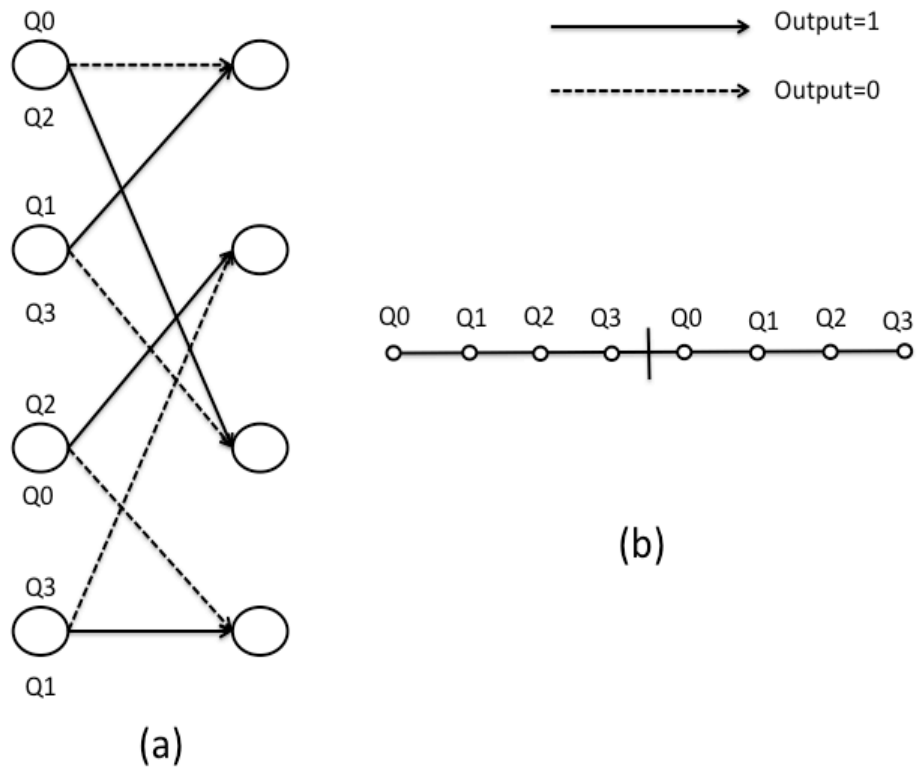

**Figure 2** (a) A 4-state trellis with subset labeling,  
 (b) Codebook partitioning for 2 bits/sample TCQ

The operation of the TCQ encoder can be explained as follows. TCQ combines scalar quantizers and trellis structures. Each time unit or stage of the trellis one source output is encoded using one of the sub-quantizers. The trellis edges are labeled with the sub-quantizers, each of rate  $R-1$ . To encode at  $R$  bits/source sample, 1 bit determines the trellis edge while the sub-quantizer  $R-1$  bits determine the point in the sub-quantizer. For an offered sequence of information to be quantized, the Viterbi algorithm [22] is applied to detect the code-words sequence (the trellis structure is used). In this way, the MSE between the information and the chosen sequence of code-words is minimized. The Viterbi algorithm is a minimum-cost search technique specifically suited for a trellis. Its performance can be explained as follows. Suppose that we have a finite-state recursive encoder.

The minimum distortion path from time instant 0 to time instant  $n$  must be an extension of the minimum distortion paths to a node at time instant  $n-1$ . Thus in order to detect the best possible path of length  $L$  we compute the best path to each state for each time unit by finding the best extension from the previous states into the current state and we perform this for each time unit up until time  $L$ . This idea is known formally as the optimality principle of dynamic programming. The algorithm itself is implemented by keeping track of the following at each time unit of the trellis: (1) the best path into each node, and (2) the cumulative distortions up to that node. The principle of optimality means that knowing the best path into a node is equivalent to knowing at each state the best possible predecessor state. When the final node is reached, that path is chosen which produces the smallest cumulative distortion.

From the above discussion of the Viterbi algorithm, it is quite clear that there is a need to keep track of the minimum distortion path for purposes of decoding. As mentioned before, one of the famous methods to encode the TCQ code-words sequence and to find the result by turning the data into a sequence of bits, is to specify one bit/sample for allocating the path over the trellis structure (which indicates the sub-quantizer used). Whereas, the code-word is allocated from the subset (sub-quantizer) selected at each point in time by using the remaining  $R-1$  bits/sample

This idea is illustrated in Fig. 3. The resulting TCQ code words would then contain all the information necessary for decoding.

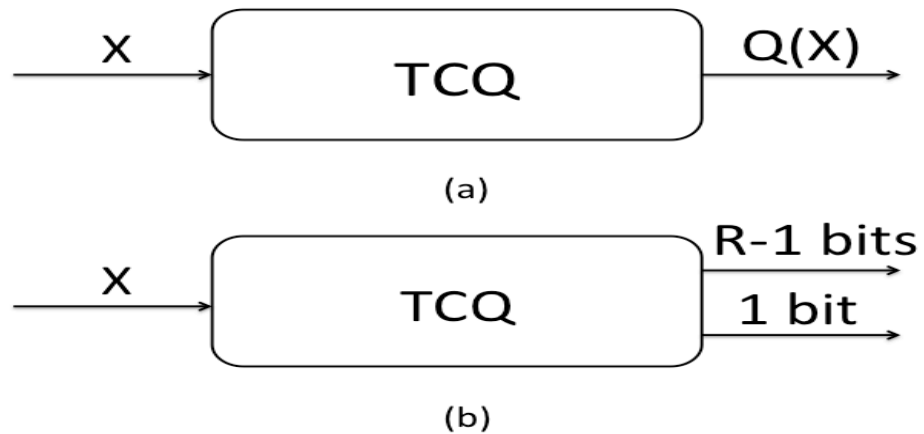

**Figure 3** (a) Symbolic representation of a TCQ, where  $X$  is the input vector and  $Q(X)$ , the quantized vector, (b) The format of the output of TCQ

### 2.1.1. A numerical example of a 4-state TCQ

In order to understand TCQ better, it would be helpful to take a look at an example. Consider the example of a 4-state TCQ and make the following assumptions:

Let the input data be in the range  $[0,1]$  and for the purpose of this example be

Input =  $\{0.785, 0.683, 0.104, 0.987\}$ .

Let the TCQ rate be  $R = 2$  bits/sample. This means that a scalar quantizer having  $2^{R+1}$  levels, i.e., 8 levels are formed, TCQ component is constructed and subsequently split up into four sub-quantizers, each having  $2^{R-1} = 2$  output points. Furthermore, let the scalar quantizer be uniform and have a support region which is the same as the range of the input, i.e.,  $[0,1]$ .



The scalar quantizer and its partitioning into four different sub-quantizers is shown in Fig. 4. The four sub-quantizers are given by

$$Q0 = \{0.0625, 0.5625\}$$

$$Q1 = \{0.1875, 0.6875\}$$

$$Q2 = \{0.3125, 0.8125\}$$

$$Q3 = \{0.4375, 0.9375\}$$

The trellis diagram for four subsequent time stages in the TCQ encoding process is shown in Fig. 5. The numbers indicated at each node are the distortions carried by taking a particular path to that node. The distortion incurred by traversing a given path is actually the lower of the two distortions in the corresponding sub-quantizer (since there are only two output points in each sub-quantizer) and the distortion is given in Table 1 for all paths in every stage. At any given time stage, the best path to each node is the lowest distortion path to that node. Thus, there are four best paths at each time stage, one for each node. Each one of the four best paths is kept tracking by using 1 bit to indicate the sub-quantizer which is used. And, (R-1) = 1 bit to indicate the output point which is used in the same sub-quantizer. Thus the trellis grows until the final data sample is reached. Now, the final best path through the trellis is the lowest distortion path of the four best paths. The distortion for each transition can be calculating by the equation below

$$\text{Distortion} = (\text{Input value} - Q_i)^2 \quad (2.1)$$

**Table 1** Distortion of Paths in Each Stage

Distortion	Stage 1	Stage 2	Stage 3	Stage 4
Q0	<b>0.0495063</b>	<b>0.0145203</b>	<b>0.00172225</b>	<b>0.1802</b>
Q1	<b>0.00950625</b>	<b>2.025e-05</b>	<b>0.00697225</b>	<b>0.0897002</b>
Q2	<b>0.00075625</b>	<b>0.0167702</b>	<b>0.0434723</b>	<b>0.0304502</b>
Q3	<b>0.0232562</b>	<b>0.0647702</b>	<b>0.111222</b>	<b>0.00245025</b>

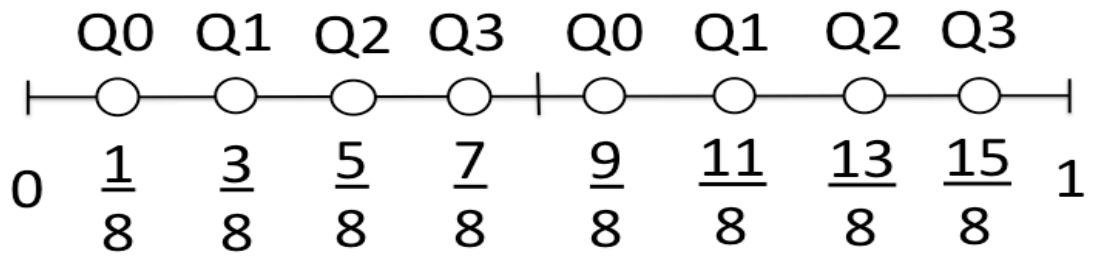

**Figure 4** Partitioning of the scalar quantizer into four sub-quantizers, for trellis coding at a rate of 2 bits/sample

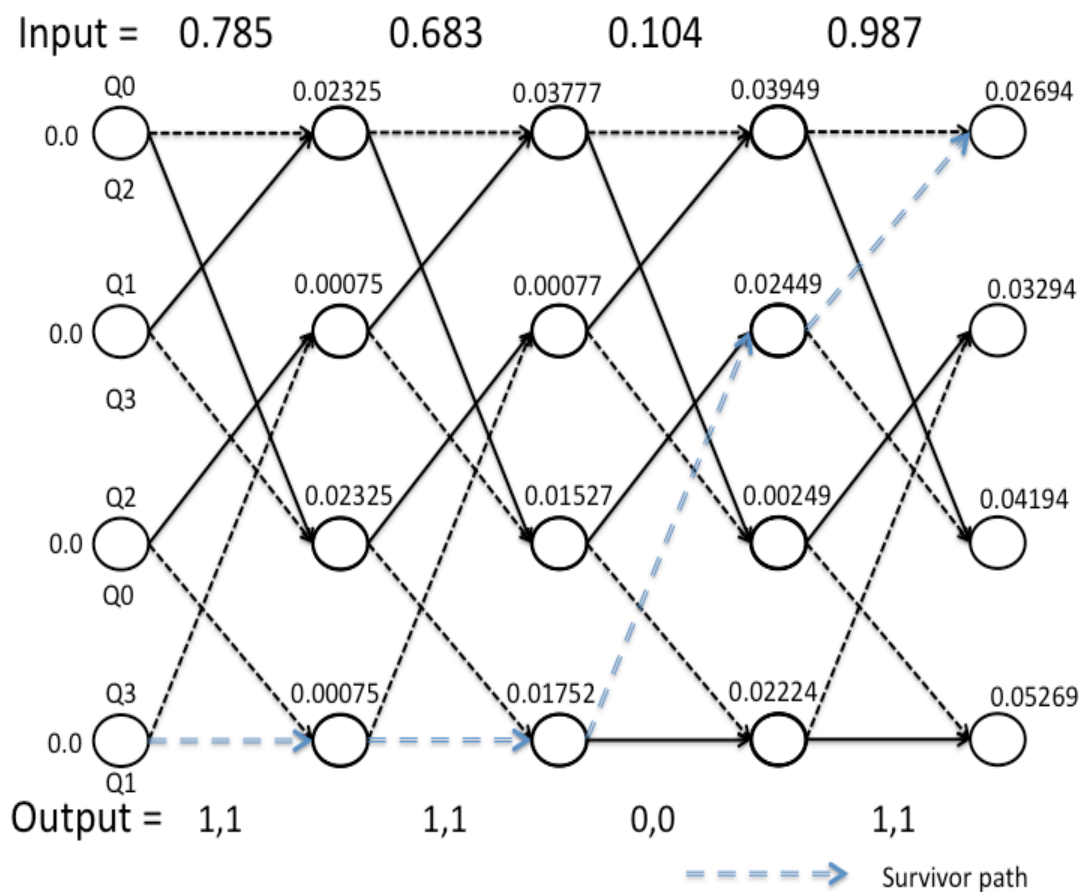

**Figure 5** An example of a 4-state trellis indicating the distortions at each node and the best path through the trellis

## 2.2. Recursive Systematic Convolutional Code (RSC)

The recursive systematic convolutional (RSC) encoder is obtained from the non-recursive non-systematic convolutional encoder by feeding back one of its encoded outputs to its input. Figure 6 shows a non-systematic convolutional encoder.

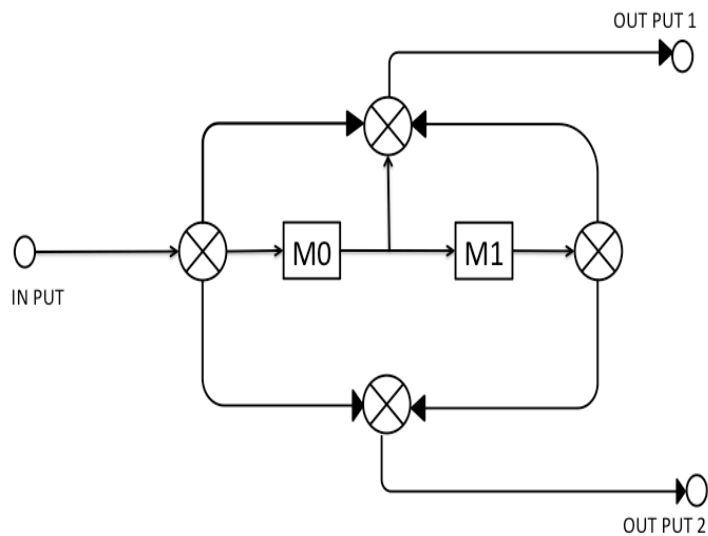

**Figure 6** Non-Systematic convolutional encoder with  $r = \frac{1}{2}$

The non-systematic convolutional encoder is illustrated by the dynamo series  $g_1 = [111]$  and  $g_2 = [101]$  and can be equivalently combined into one matrix expression as  $G = [g_1, g_2]$ . The RSC encoder of this non-systematic convolutional encoder is indicated by  $G = [1, g_2 / g_1]$  where the numerator term (referred to as  $g_1$ ) describes the feedback path directly to the input. In Fig. 7 the structure of RSC encoder is described.

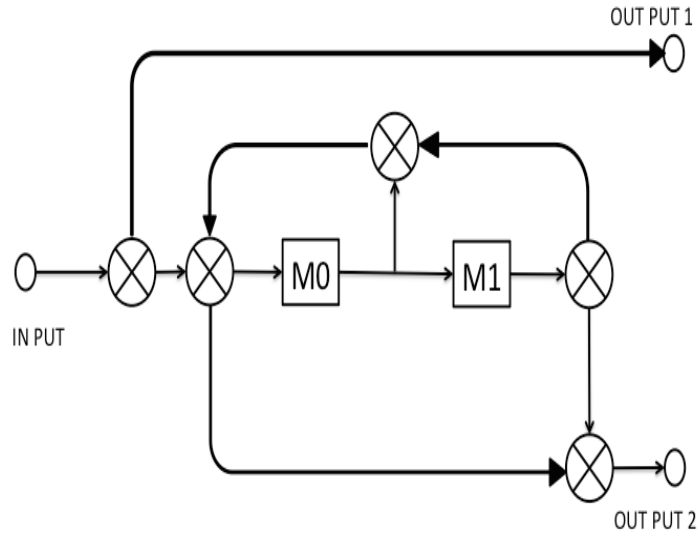

**Figure 7** The RSC encoder structure,  $r=1/2$  and  $K=3$

It is known that the perfect codes could be gained by synchronizing the feedback of the RSC encoder to a primal polynomial which creates extreme-extended series.

### 2.3. MAP algorithm

The MAP algorithm is a popular algorithm used in iterative decoding of concatenated codes. It has huge amount of mathematical computation which makes its application difficult for practical systems. The Log-MAP and Max-Log-MAP algorithms are modified version of the MAP algorithm [23] for ease of implementation.

MAP algorithm computes LLRs for each data bit as

$$L(u_k) = \ln \left[ \frac{\sum_{S_k} \sum_{S_{k-1}} \gamma^1(S_{k-1}, S_k) * \alpha(S_{k-1}) * \beta(S_k)}{\sum_{S_k} \sum_{S_{k-1}} \gamma^0(S_{k-1}, S_k) * \alpha(S_{k-1}) * \beta(S_k)} \right] \quad (2.2)$$

where  $\alpha$  is the forward state probability,  $\beta$  is the backward state probability,  $\gamma$  is the branch metric,  $S_k$  denotes the state at time instant  $k$ , and  $S_{k-1}$  is the trellis state at time instant  $k-1$ . Recursive computation of forward state metrics can be done using

$$\alpha_k(S_k) = \sum_{S_{k-1}} \gamma_k^i(S_{k-1}, S_k) * \alpha_{k-1}(S_{k-1}) \quad (2.3)$$

Similarly, the backward state metrics are recursively computed as follows:

$$\beta_{k-1}(S_{k-1}) = \sum_{S_k} \beta_k(S_k) * \gamma_k^i(S_{k-1}, S_k) \quad (2.4)$$

Branch metrics are computed for every allowable state transition as

$$\gamma_k(S_{k-1}, S_k) = P(u_k) * P(y_k | c_k) \quad (2.5)$$

where the initial values for a-priori probabilities are  $P(u_k=1)=1/2$  and  $P(u_k=0)=1/2$ , and

$$\gamma_k^i(S_{k-1}, S_k) = P(u_k) * \left(\frac{1}{2 * \pi * \sigma^2}\right) * e^{\left(\frac{-1}{2 * \sigma^2}\right) * \left((y_k^1 - c_k^1)^2 + (y_k^2 - c_k^2)^2\right)} \quad (2.6)$$

where  $i$  can be either 0 or 1,  $c_k^1$  and  $c_k^2$  are the information and parity bits, and,  $y_k^1$  and  $y_k^2$  are the noisy received signals.

Initial values for the forward and backward state metrics, assuming no trellis termination is performed, are set as:

$$\alpha_0(S_0) = \begin{cases} 1 & S = 0 \\ 0 & \text{other wise} \end{cases}$$

$$\beta_N(S_N) = \begin{cases} \frac{1}{4} & \text{for every } s \end{cases}$$

The a-posteriori probabilities for the information bits are computed as:

$$P(u_k = 1 | y_k) = \sum_{u_k=1} (\alpha_{k-1}(S_{k-1}) * \gamma_k^1(S_{k-1}, S_k) * \beta_k(S_k)) \quad (2.7)$$

$$P(u_k = 0 | y_k) = \sum_{u_k=0} (\alpha_{k-1}(S_{k-1}) * \gamma_k^0(S_{k-1}, S_k) * \beta_k(S_k)) \quad (2.8)$$

And the LLRs for every data bit is computed via

$$L(u_k) = \frac{p(u_k = 1|y_k)}{p(u_k = 0|y_k)} \quad (2.9)$$

After a sufficient number of iterations, the decision on the transmitted bit is done using

$$u_k = \begin{cases} 0 & L(u_k) < 1 \\ 1 & L(u_k) > 1 \end{cases}$$

#### 2.4. Semi-Random Interleaver (S-R Interleaver)

The semirandom interleaver is the one between a random interleaver and an “algebraic” interleaver. The construction of S-Random interleaver is explained as below:

Stage 1. Pick a random integer  $i \in [0, L - 1]$ .

Stage 2. Choose a positive number (integer)  $S < \sqrt{\frac{L}{2}}$ .

Stage 3. Pick another integer  $j \in [0, L - 1]$  such that  $|i-j| < S$ , and this comparison should be satisfied between  $i$  and  $S-1$  previously chosen integers ( $j$ ).

Stage 4. Go to Stage 1 until all the integers are selected from the vector  $[0, L - 1]$ .

## 2.5. Space -Time Block Codes (STBC)

Space-time block codes (STBC) [24] are a higher version of Alamouti codes [25]. The previous codes are orthogonal. By the number of transmit antenna elements, Space-time block codes can be obtained a full transmit diversity. In another expression, Alamouti's space-time code is less complex version than space-time block codes (STBC), on the transmitter side and receiver side, the encoding and decoding parts in the Alamouti space-time code are the same. The information is made as a matrix. This matrix has columns and rows. The columns of matrix are equal to the transmit antennas' number and the rows of matrix are equal to the time slots' number which is needed to send the information. At the destination part, the received signals are first combined after that passed the data to the maximum likelihood (ML) detector where important procedures are made.

Space-time block codes (STBC) are invented to gain the maximum diversity order for the antenna elements' number which is provided (transmit and receive antenna elements), the aim is to focus on getting a normal linear decoding algorithm. The previous reason is made space-time block codes (STBC) a very common and most widely scheme which is used in wireless communication systems.

Training-based methods [26] are simulated and given a very good performance results on the channel estimation area research at the destination. Pure training-based schemes are possible to take an advantage when reliable and an accurate MIMO channel system is needed to achieve. But, when bandwidth efficiency is needed, training-based schemes can be a disadvantage. The reason behind the disadvantage is that the pure training-based schemes decrease the bandwidth efficiency frequently because of using a long training sequence which is necessarily required for having a reliable MIMO channel system. A lot of wireless communication networks are still in used pilot sequences at the destination side which is aimed to estimate the channel parameters, due to the computing complexity of semi-blind and blind methods.

### 2.5.1. Alamouti scheme

Alamouti scheme is developed to be a special case of the Space Time Coding technique. This scheme is explained in mathematical way for the case that the number of transmitter antenna elements is two and the number of receiver antenna element is one. In this research, the scheme which is implemented has a two-branch transmit diversity. By using two transmit antenna elements and one receive antenna element, the scheme is given the same diversity order when is compared with maximal ratio receiver combining (MRC) [27] in the case that the number of transmit antenna element is one and the number of receive antenna element is two antennas. To give diversity order of  $2M$ , the scheme can easily become generalized to two transmit antenna elements and  $M$  receive antenna elements. By increasing the number of transmit or receive antenna element the system will become powerful. At the transmitter side, the modulator is received a block of two symbols which is taken from the source data. After the previous procedures, Alamouti space-time encoder takes the two modulated symbols, in this case called  $s_1$  and  $s_2$  creates encoding matrix  $S$  where the symbols  $s_1$  and  $s_2$  are located to two transmit antenna elements in two transmit time slots. The encoding matrix is given by:

$$S = \begin{matrix} Tx_1 & Tx_2 \\ \begin{bmatrix} s_1 & s_2 \\ -s_2^* & s_1^* \end{bmatrix} & \begin{matrix} t_0 \\ t_1 \end{matrix} \end{matrix} \quad (2.10)$$

The fading coefficients are given as  $h_1(t)$  and  $h_2(t)$  and assumed constant across the two consecutive symbol transmission periods and they can be shown as follow:

$$h_1(t) = h_1(t+T) = h_1 = |h_1|.e^{j\theta_1} \quad (2.11)$$

$$h_2(t) = h_2(t+T) = h_2 = |h_2|.e^{j\theta_2} \quad (2.12)$$



The receiver receives  $r_1$  and  $r_2$  are given as a two received signals through a two sequential symbol periods for time  $t$  and  $t+T$ . The signals which is received can be shown as:

$$\begin{bmatrix} r_1 \\ r_2 \end{bmatrix} = \begin{bmatrix} s_1 & s_2 \\ -s_2^* & s_1^* \end{bmatrix} \begin{bmatrix} h_1 \\ h_2 \end{bmatrix} + \begin{bmatrix} n_1 \\ n_2 \end{bmatrix} = \begin{bmatrix} h_1 s_1 + h_2 s_2 + n_1 \\ -h_1 s_2^* + h_2 s_1^* + n_2 \end{bmatrix} \quad (2.13)$$

The maximum likelihood (ML) decoder is taken a signals' pair  $(\hat{s}_1, \hat{s}_2)$  from the signal constellation, which aimed to minimize the distance metric through all possible values of  $\hat{s}_1$  and  $\hat{s}_2$ .

$$d_2(r_1, h_1 \hat{s}_1 + h_2 \hat{s}_2) + d_2(r_2, -h_1 \hat{s}_2^* + h_2 \hat{s}_1^*) = |r_1 - h_1 \hat{s}_1 - h_2 \hat{s}_2|^2 + |r_2 + h_1 \hat{s}_2^* - h_2 \hat{s}_1^*|^2 \quad (2.14)$$

The maximum likelihood detector is received the following two combined signals which is processed in the combiner that is shown in Fig. 8.

$$\begin{bmatrix} \overline{S_1} \\ \overline{S_2} \end{bmatrix} = \begin{bmatrix} h_1^* & h_2 \\ h_2^* & -h_1 \end{bmatrix} \begin{bmatrix} r_1 \\ r_2 \end{bmatrix} = \begin{bmatrix} h_1^* r_1 + h_2 r_2^* \\ h_2^* r_1 + h_1 r_2^* \end{bmatrix} \quad (2.15)$$

The Alamouti scheme system's encoder and decoder are shown in Fig. 8. Before send the information to the destination, the information is modulated and given to the space-time encoder. As part of the multiple input multiple output (MIMO) technology, the space-time encoder is included of two transmit antennas [28]. Through two separate antennas, the information is transmitted. There is a separate channel for every transmitting and receiving antenna pair (represented by different channel coefficients). The design of the system is related to these coefficients of channels which is played an important part in the system. The system's complexity is increased when the antennas' number is increased at both sides of the channel.

In the destination site, the received signal is given to the channel estimator through received antenna element. The maximum likelihood detector is taken together both of information from the combiner and channel's estimated coefficients as an input. After the maximum likelihood detector is worked, the detected signal is given to the demodulator. And the demodulator is fed the processing data which is transported.

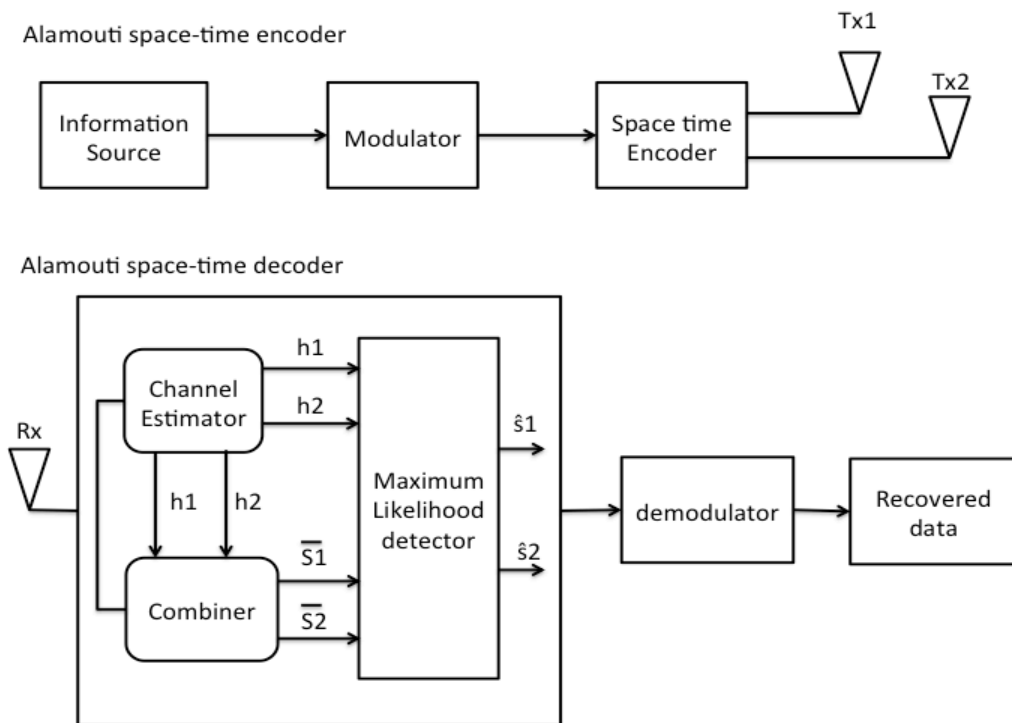

**Figure 8** Alamouti space-time encoder and decoder for 2-Tx and 1-Rx

The space-time block codes (STBC) are the higher version of the Alamouti scheme. i.e, the space-time block codes are also increased the system performance when the antennas' number is increased in the Alamouti scheme. As an example of the STBC's, a case of two transmitted antennas and two receive antenna elements is also explained here.

The encoding part is the same as in the previous case the difference in this case is the fading coefficients denoted by  $h_1(t)$ ,  $h_2(t)$ ,  $h_3(t)$  and  $h_4(t)$  are assumed constant across the four sequential symbol transportation periods and these symbols possible to be defined as:

$$h_1(t) = h_1(t+T) = h_1 = |h_1|.e^{j\theta_1} \quad (2.16)$$

$$h_2(t) = h_2(t+T) = h_2 = |h_2|.e^{j\theta_2} \quad (2.17)$$

$$h_3(t) = h_3(t+T) = h_3 = |h_3|.e^{j\theta_3} \quad (2.18)$$

$$h_4(t) = h_4(t+T) = h_4 = |h_4|.e^{j\theta_4} \quad (2.19)$$

In Figure 9 fading coefficients over four channels from Tx to Rx are shown. The receiver receives  $r_1, r_2, r_3$  and  $r_4$  represent the four signals which is received through the four sequential symbol periods for time  $t$  and  $t+T$ . The signals which is received can be shown as:

$$r_1 = (h_0 .S_1)+(h_1 .S_2)+n_1 \quad (2.20)$$

$$r_2 = -(h_0 .S_2^*)+(h_1 .S_1^*)+n_2 \quad (2.21)$$

$$r_3 = (h_2 .S_1)+(h_3 .S_2)+n_3 \quad (2.22)$$

$$r_4 = -(h_2 .S_2^*)+(h_3 .S_1^*)+n_4 \quad (2.23)$$

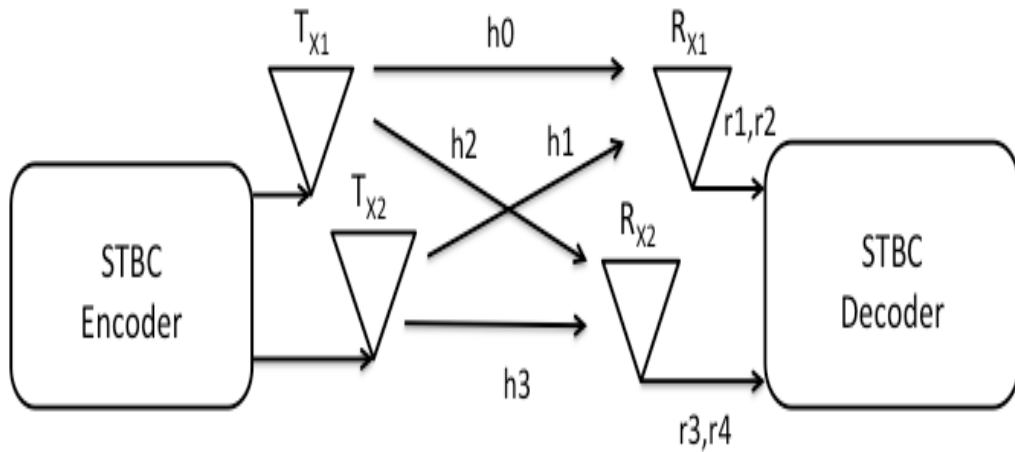

**Figure 9** Fading coefficients for 2-Tx and 2-Rx

A pair of signals ( $\hat{s}_1, \hat{s}_2$ ) is chosen by the maximum likelihood (ML) decoder from the signal constellation. The aim of the previous process is to minimize the distance metric through all possible values of  $\hat{s}_1$  and  $\hat{s}_2$  and find the probabilities for all of them as below

$$P(\hat{s}_1) = P(s_1) \cdot (|(r_1 \cdot h_0) + (r_2^* \cdot h_1) + (r_3 \cdot h_2) + (r_4^* \cdot h_3) - X_{S_k}|^2 + (|h_0|^2 + |h_1|^2 + |h_2|^2 + |h_3|^2)) \quad (2.24)$$

$$P(\hat{s}_2) = P(s_2) \cdot (|(r_1 \cdot h_1) - (r_2^* \cdot h_0) + (r_3 \cdot h_3) - (r_4^* \cdot h_2) - X_{S_k}|^2 + (|h_0|^2 + |h_1|^2 + |h_2|^2 + |h_3|^2)) \quad (2.25)$$

where  $X_{S_k}$  represent complex symbols in this case 4-PSK is used in all systems for this reason  $X_{S_k}$  will take these value  $\{1, -1, j, -j\}$  and  $P(s_1), P(s_2)$  is the probabilities for complex symbols which are fed from other component if the system is iterative one if not and for initial value  $P(s_k)=1/4$ .

The encoder part and decoder part of the Alamouti scheme system for the case that have 2-Tx and 2-Rx are shown in Fig. 10. Here the data is modulated then given to the space-time encoder. And the final processing is transmitted to the destination. The space-time encoder is having two transmit antenna elements and the space-time decoder is having also two receive antenna elements as part of the multiple input multiple output (MIMO) technology. In this case the data is transmitted over two separate transmit antenna elements in the transmitter into two separate receive antenna elements at the destination. Every transporting and receiving antenna pair has a separate channel (i.e. in this case there are four separate channels), clarify the channel coefficients is different from each other. The most important thing that plays a major role in the design of the system is the multi diversity of channel coefficients. As the antennas' number becomes larger at both side of the channel, the complexity of the system also increases.

In the receiver side, the signals which is received, are given to the channel estimator. The channels' coefficients, which is estimated together with the data from combiner, are fed as the input to the maximum likelihood (ML) detector. The signals which is processed, are then given to the demodulator. The demodulator is fed the processing data which is sent.

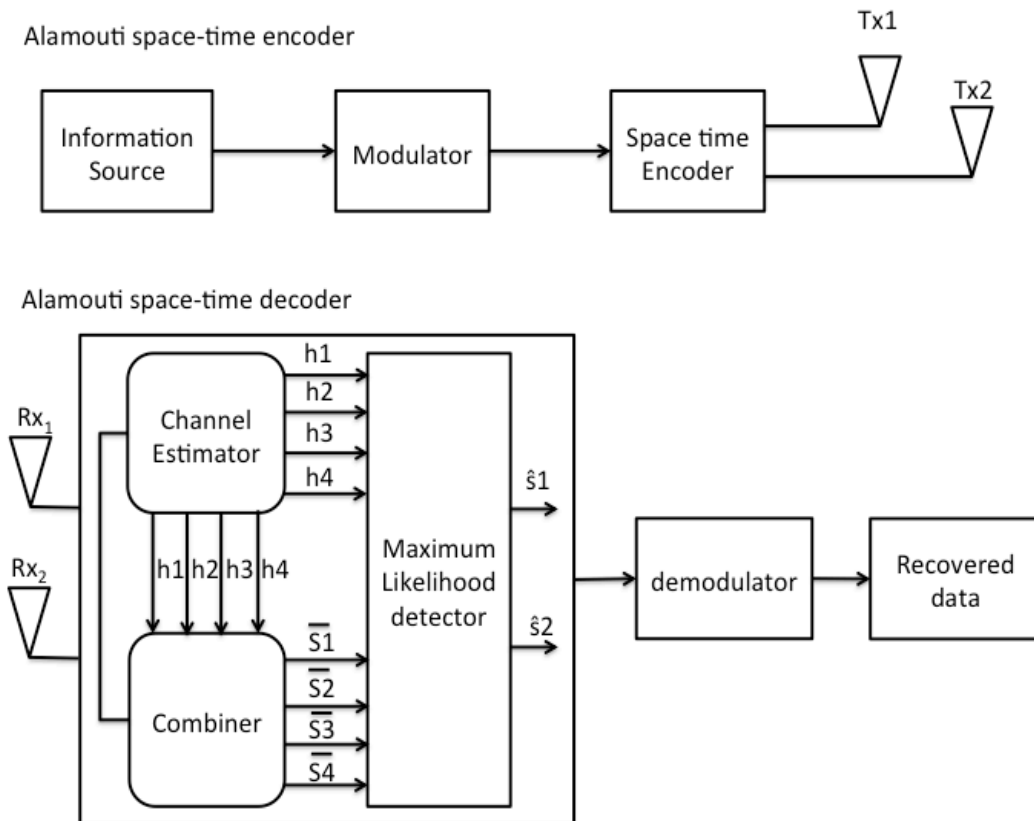

**Figure 10** Alamouti space-time encoder and decoder for 2-Tx and 2-Rx

## CHAPTER 3

### JOINT TRELLIS CODED QUANTIZATION WITH SPACE TIME BLOCK CODING

#### 3.1. Classical System Strategy

In this structure we propose a joint structure involving trellis coded quantization (TCQ) and space-time block coding (STBC). The encoded symbol is transmitted through Rayleigh channels as it is shown in Fig. 11. In the TCQ encoder, which is explained in chapter 2 (2.1), data is quantized and encoded to binary bits  $B_k$ . As it is explained before, the first output bit represents the survivor path which is founded by Viterbi algorithm and the second output bit is the quantization bit. The quantization bit is totally depended on the scalar quantizer as it is shown in Fig. 4. If the input values bigger than 0.5 the second output-bit is 1 otherwise it is 0. After encoding by TCQ the bit stream is passed through S-R interleaver and moved to 4-PSK modulator. The bit stream is converted into complex symbols  $S_k$  and sent to space-time block coder (STBC). Final processing in the transmitter is the encoding of the complex symbols by Alamouti scheme which is special case of STBC (as explained in Chapter-2 in Section 2.5.1). In this system two transmit antenna elements (Tx1 and Tx2) are used to transmit the complex symbols through Rayleigh channel and two receive antenna elements (Rx1 and Rx2) at the destination are also used to receive the signals.

The receiver part is shown in Fig. 11. The signals are received through two receive antennas and decoded by STBC (explained in 2.5.1) and passed the complex-symbol probabilities  $P(\hat{s}_k)$  to the convertor. The probabilities are received by the convertor and the converted bit probabilities  $P(B_k)$  are sent to inverse S-Random interleaver. After that, the bits probabilities are re-ordered by inverse S-Random interleaver and passed to TCQ decoder to find and estimate the original data (real values).

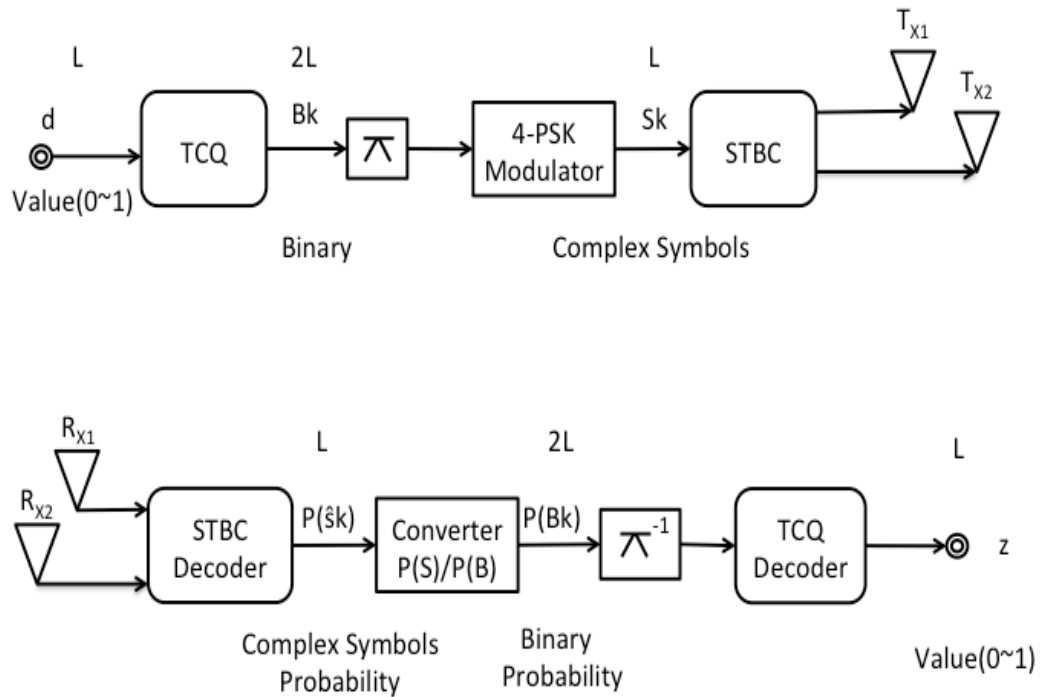
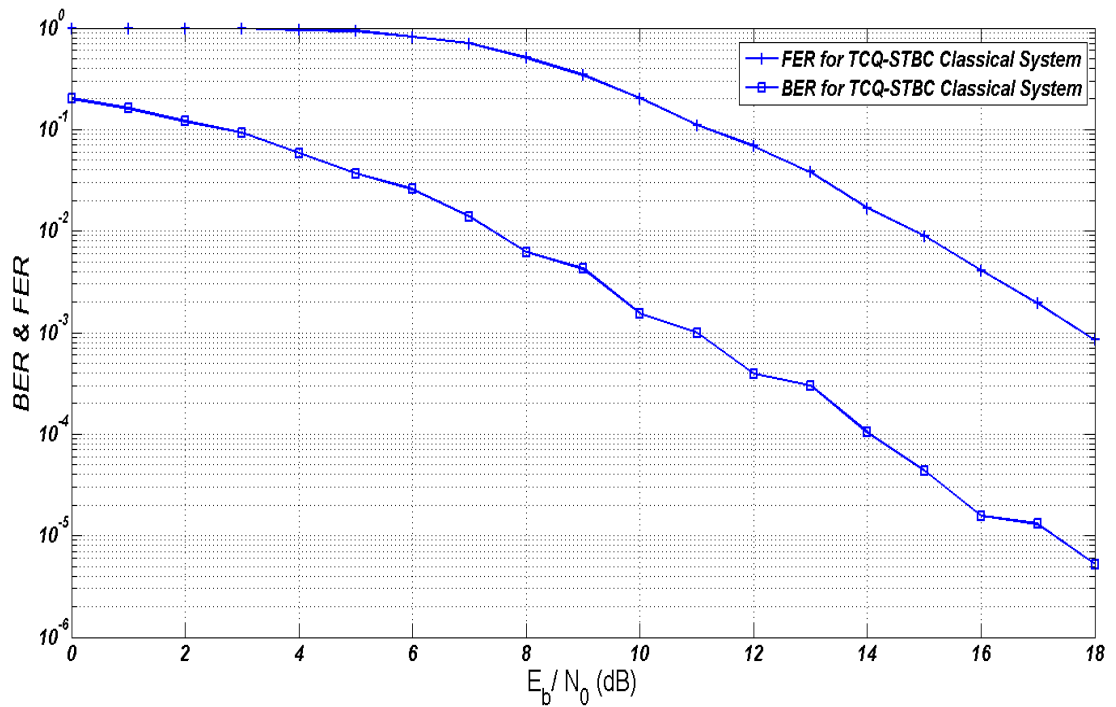

**Figure 11** Encoder and decoder forms for *Classical System*,  $L$  frame length

In Figure 12 Bit Error Rate (BER) and Frame Error Rate (FER) simulation results for the *Classical System* are shown. The information frame length  $L$  is chosen as 1024, real values between 0 and 1. The system rate is equal to  $1/2$ . S-Random interleaver is used in all the systems with  $S=20$ . All the channels that are used are half-duplex and Rayleigh distributed. Perfect channel estimation is assumed at the receiver side.

In Figure 13 the distortion for the *Classical System* with respect to Signal to Noise Ratio (SNR) is depicted. Frame number, which is transmitted from the source to the destination, is equal to 1000 for each SNR value.

All the results are obtained via computer simulation and the software is written in C++ language.



**Figure 12** *Classical System* Bit Error Rate (BER) and Frame Error Rate (FER) results



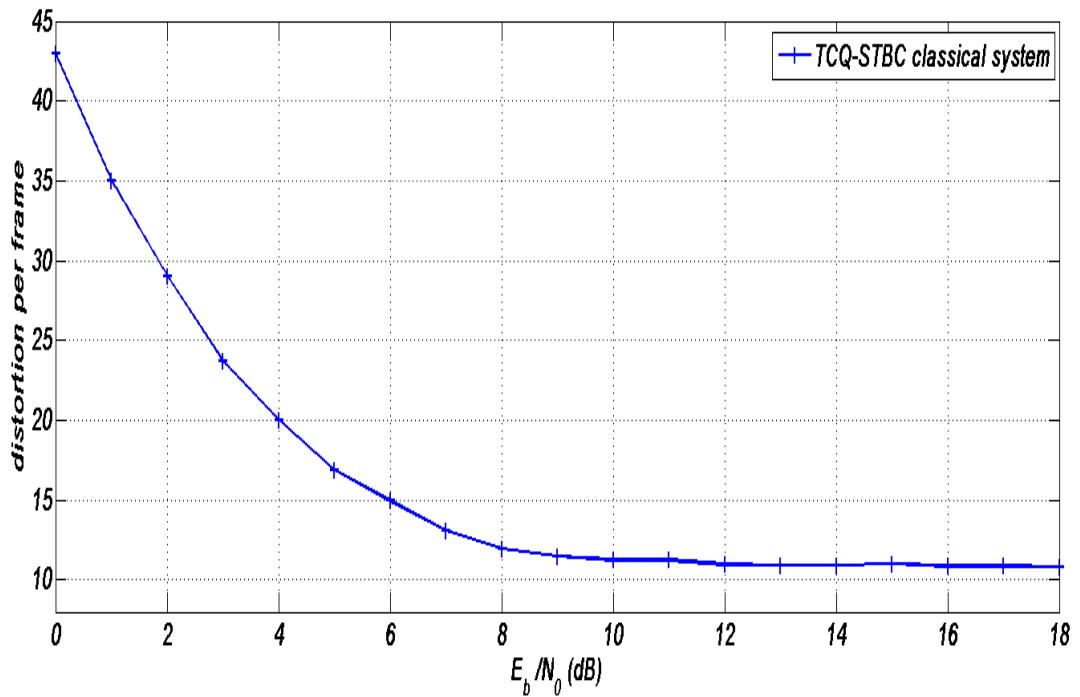

**Figure 13** *Classical System* distortion results

### 3.2. Triple Component System Structure (TCQ-RSC-STBC)

This system is designed to increase the system performance by taking the advantage of iterative decoding operation at the receiver. The  $RSC(1, 5/7)_{\text{octal}}$  encoder (explained in 2.2) is added to the system after TCQ encoder as it is shown in Fig. 14. The input data  $d$  (real valued) are encoded by TCQ encoder and bit stream  $B^1k$  is obtained and fed to the RSC encoder whose output produces the bit-stream  $B^2k$ . The bit stream  $B^2k$  is interleaved by S-R interleaver and modulated (4-PSK modulator), producing complex symbols  $S_k$  which are passed to the space time block coder (STBC). Complex symbols  $S_k$  are encoded by space-time block coder (STBC) where Alamouti codes are employed. The encoded symbols are transmitted through Rayleigh channels via two transmit antennas  $T_x$ . At the destination two receiver antennas are employed.

The aim of this updating is to make iterative decoding between STBC and RSC decoders. In this scheme, the system gained a powerful performance as it is shown in Fig. 15; the curve for bit error rate (BER) for this system is better than the curve of *Classical System*. And also in the Fig. 16, the frame error rates (FER) are depicted and compared to *Classical System*.

In the RSC decoder, MAP algorithm is used to find the bit probabilities and the obtained probabilities are fed into the STBC decoder as a-priori probabilities. After the iterative decoding is finished the probabilities are passed to TCQ decoder to find and decode the original data  $Z$ . Distortion between  $Z$  and  $d$  is computed. The distortion equation is presented in (2.1) and the result is shown in Fig. 17 where the obtained result is compared to the distortion of *Classical System* and seen that a significant improvement is obtained with the proposed method. The number of frames, which is transmitted from the source to the destination, for every signal to noise ratio (SNR) equals to 1000 frames.

The input frame length  $L$ , which is used in the simulation, contains 1024 numbers to be quantized. S-R interleaver is also used in this system with  $S=20$  and the number of iterations equal 8.

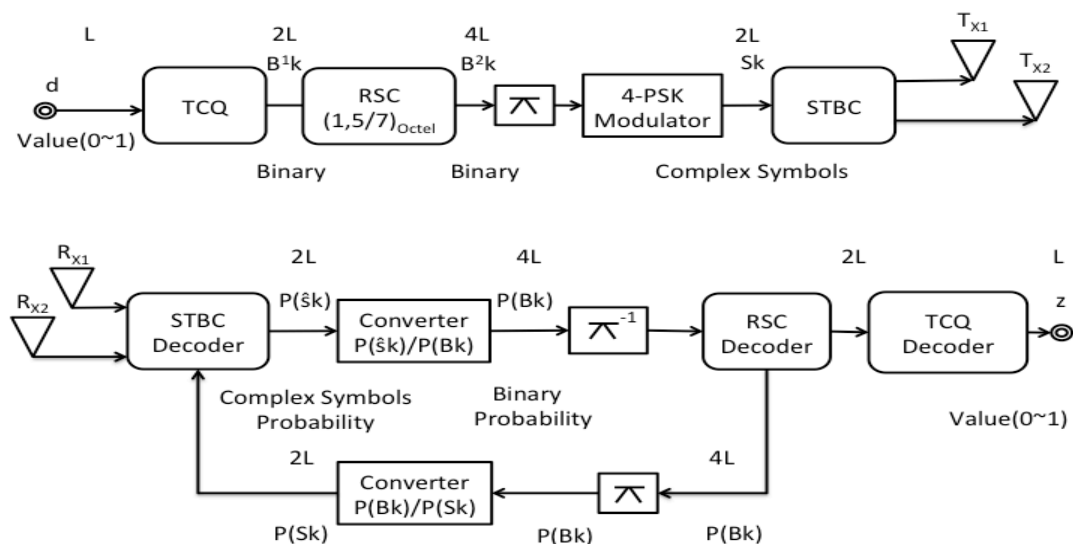

**Figure 14** Encoder and decoder structures for *Triple Components System*,  $L$  is the frame length

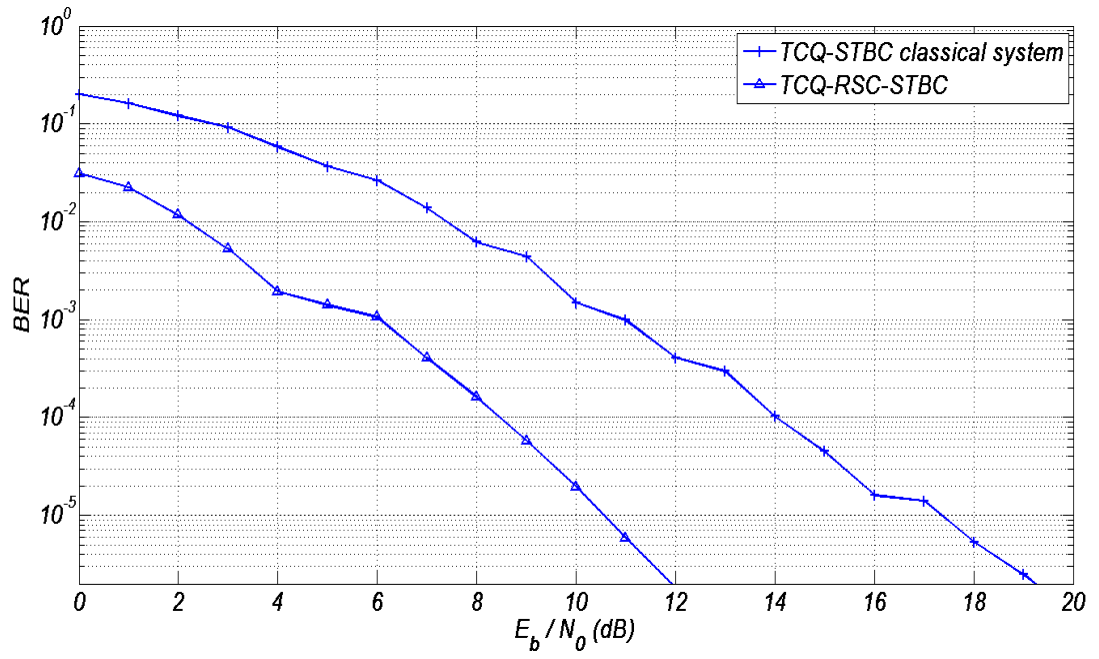

**Figure 15** Triple Components System Bit Error Rate (BER) results

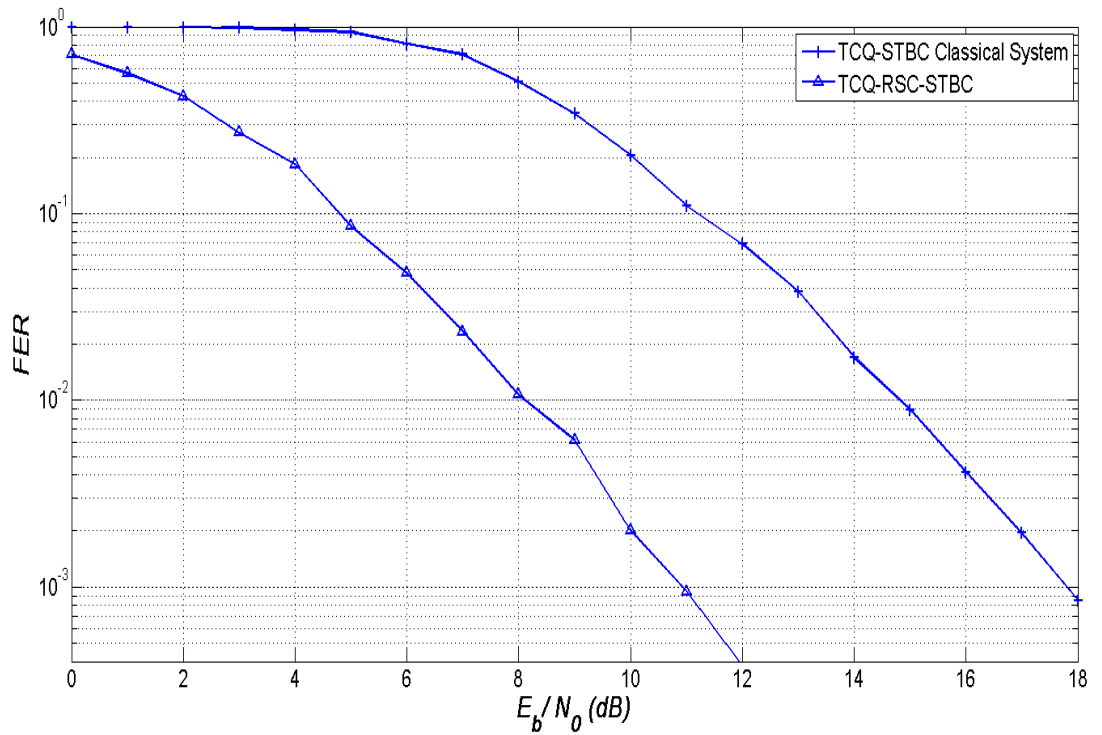

**Figure 16** Triple Components System Frame Error Rate (FER) results

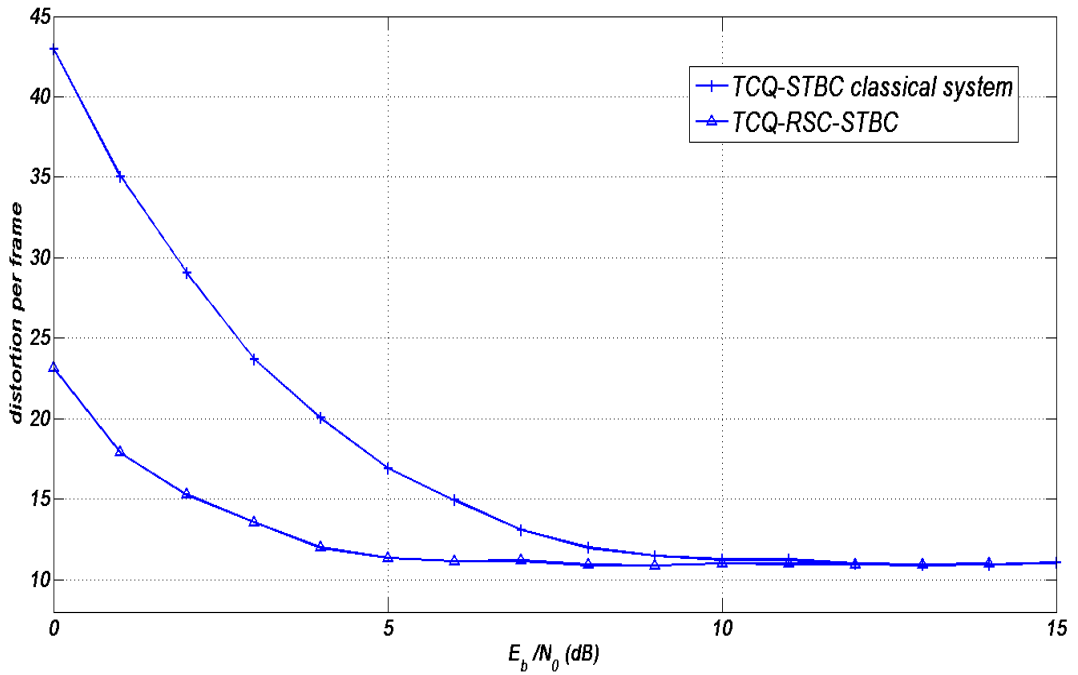

**Figure 17** Triple Components System distortion results

### 3.3. Dual Component System Structure (TCQ-STBC Iterative System)

In this system a new structure for trellis coded quantization (TCQ) is developed suitable for iterative decoding. The proposed system employs RSC  $(1, 5/7)_{\text{octal}}$  trellis structure and quantizer levels are assigned to the state transitions as shown in Fig. 19. Viterbi algorithm is applied during the encoding operation.

In this new TCQ the quantizer bits are replaced by the complementary bit of RSC $(1, 5/7)_{\text{octal}}$  as is shown in part-a of Fig. 19. It is obvious from the Fig. that the output for each transition (each real values representation) from one state to another contains two bits. Using the trellis structure of RSC $(1, 5/7)_{\text{octal}}$  it is possible to employ MAP algorithm for iterative decoding in the TCQ decoder, and sent the probabilities from TCQ decoder to the space-time block coding (STBC) decoder as a-priori probabilities to start a new decoding cycle (iterative) as is shown in Fig. 18. For the proposed method, the structure of the quantizer used in the encoder and decoder is as shown in part-b of Fig. 19.

The quantizer is extended from Q0 to Q7 (instead of Q0 to Q4 and repeated again) and re-ordered in the trellis diagram for the new TCQ (shown in part-a of Figure 19).

By joining the new TCQ and STCB the system gained a powerful performance, when it is compared to the *Classical System* (i.e. this two systems have the same rate which is  $1/2$ ), and has less performance when it is compared to the *Triple Component System Structure*.

In Figure 20 the performance comparison between the *Classical System*, *Triple Components System* and the *Dual Components System* in terms of bit error rate (BER) is depicted. And in Fig. 21 frame error rate (FER) results are shown.

For the computer simulations the frame length of input data  $L$  is chosen to be equal to 1024 in all systems. And  $S=20$  for S-R interleaver. The 4-phase-shift keying (4-PSK) is used in all the systems for modulation. All the systems in the simulations employs two transmit and two receive antenna elements over fading channels. And perfect-channel estimation is considered for all systems. The type of space-time block coding (STBC) used for encoding and decoding is Alamouti scheme.

The distortions for all the systems are shown in Fig. 22. In all systems the number of frames, which are transmitted from source to destination, is chosen to be 1000 for each SNR.

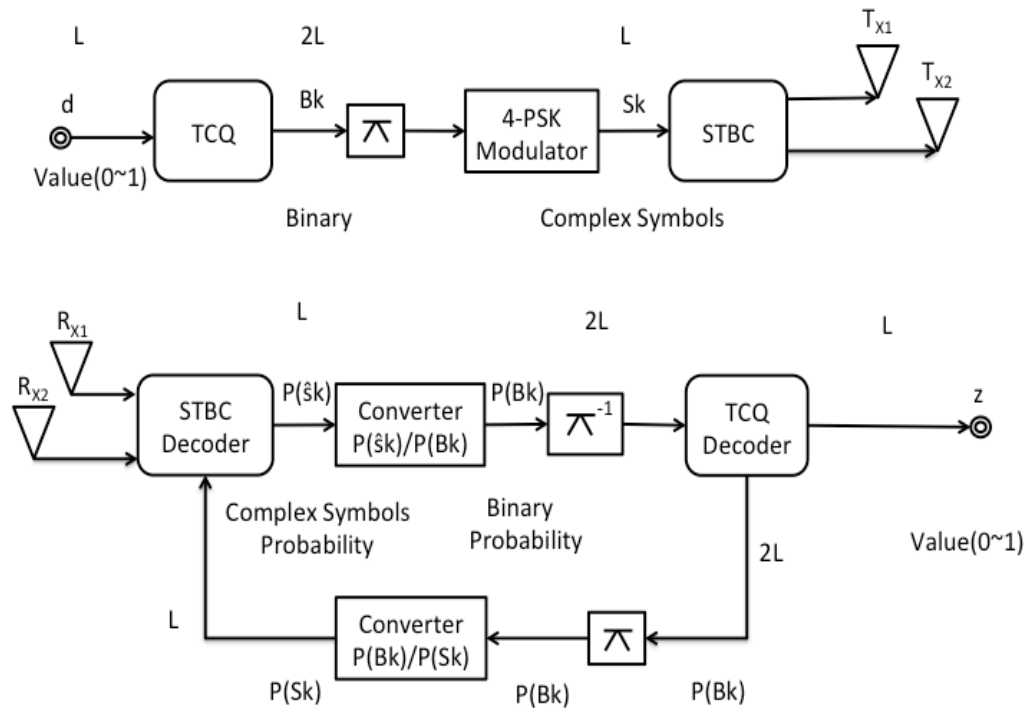

**Figure 18** Encoder and decoder forms for *Dual Components System*,  $L$  frame length

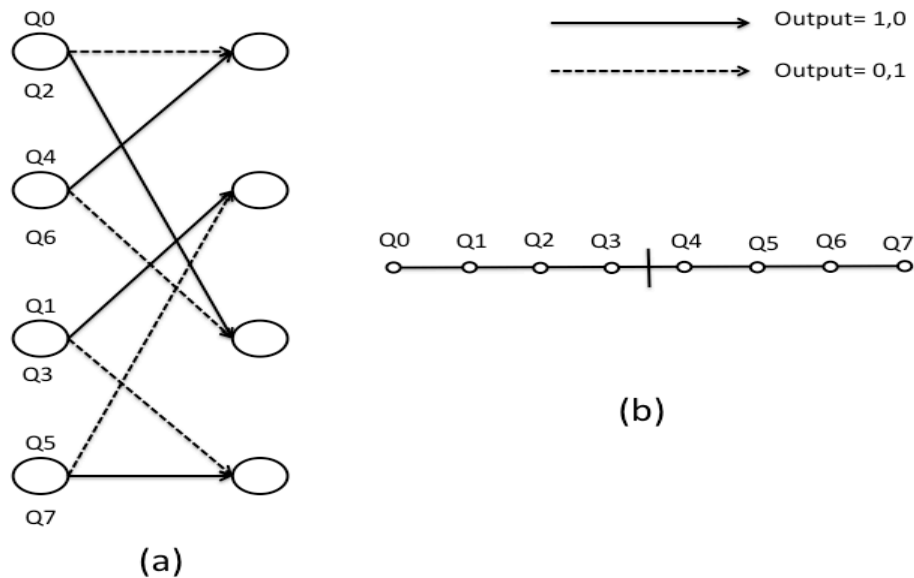

**Figure 19** *Dual Component System* (a) a 4-state trellis with subset labeling, (b) Codebook partitioning for 2 bits/sample TCQ

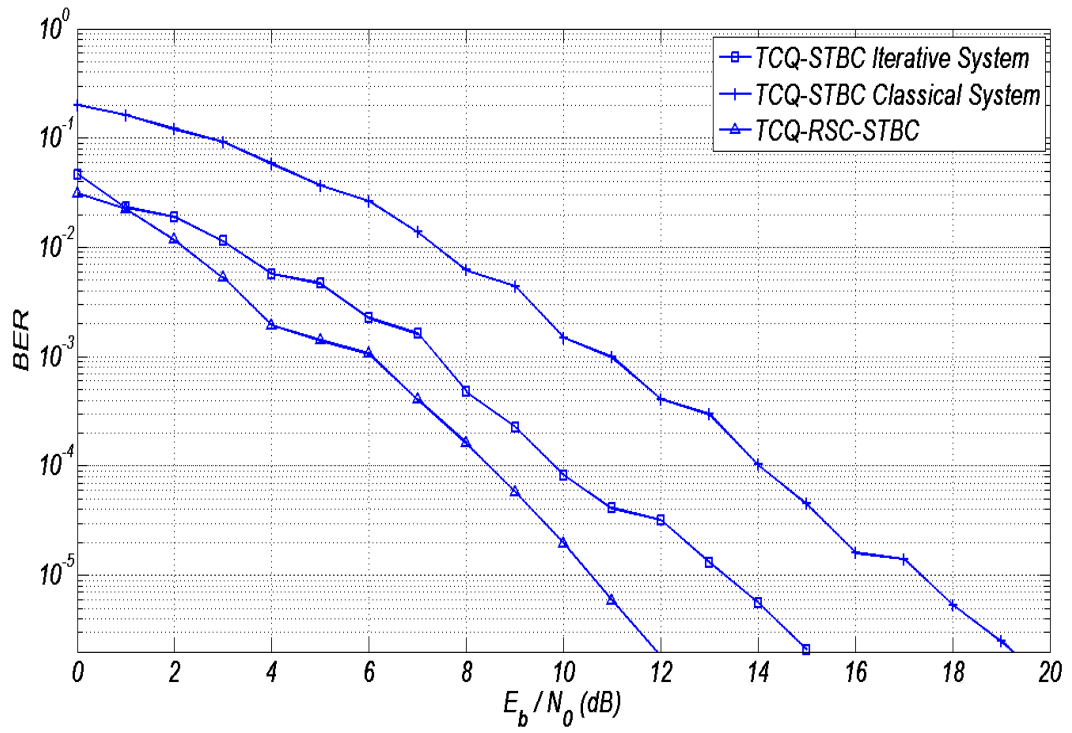

**Figure 20** Dual Component System Bit Error Rate (BER) results

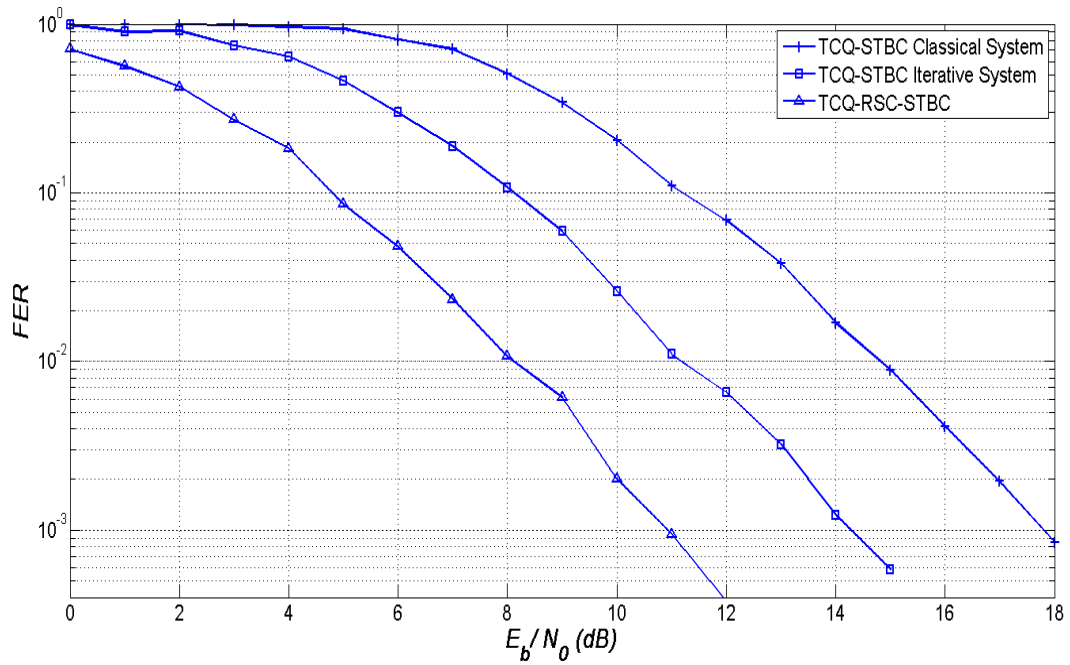

**Figure 21** Dual Component System Frame Error Rate (FER) results

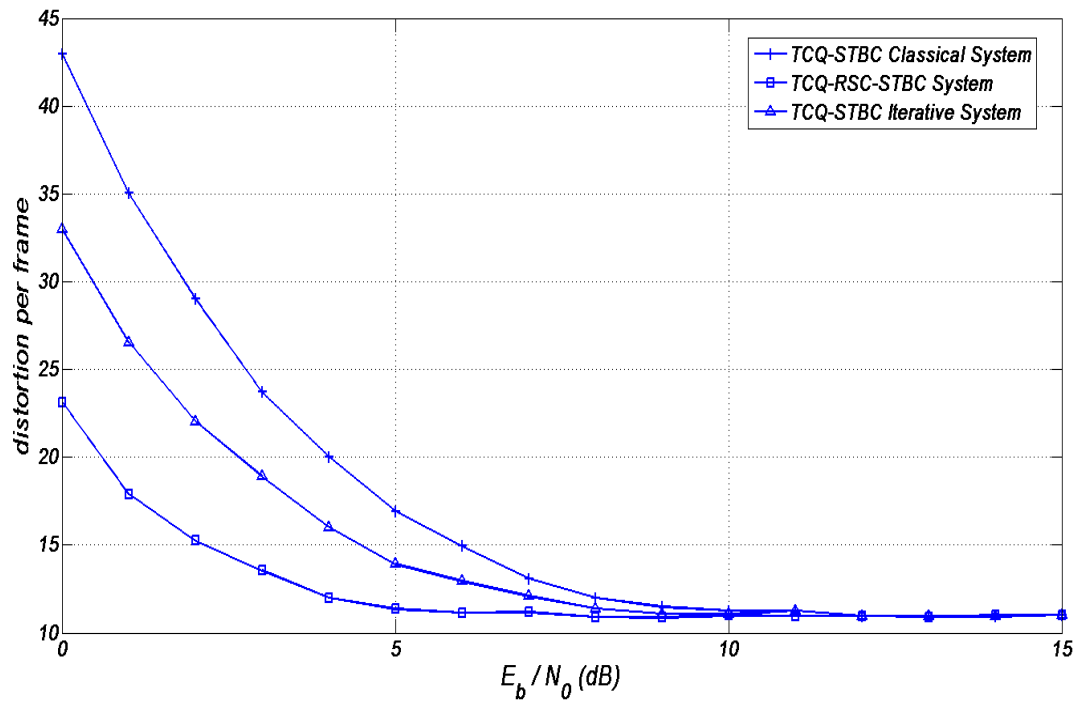

**Figure 22** *Dual Component System distortion results*

The advantage and disadvantage for the previous structures are compared in Table 2 in terms of system performance, code rate, and hardware complexity.



**Table 2** Comparisons Among *Classical System*, *Triple Components System* and *Dual Components System*

<div style="text-align: right;">Systems Features</div> <div style="text-align: left;">Ideas</div>	Performance	System Rate	Hardware Complexity
<i>Classical System</i>	Good	1/2	Normal
<i>Triple Components System</i>	Very good	1/4	Higher Hardware Complexity than the Other Systems
<i>Dual Components System</i>	Better than <i>Classical System</i> and less than <i>Triple Components System</i>	1/2	Higher Hardware Complexity than the <i>Classical System</i> and less than <i>Triple Component System</i>

## CHAPTER 4

### CONCLUSION AND FUTURE WORK

This thesis gives a basic overview of the TCQ and MIMO technology. A basic introduction to Space-Time Block Coding (STBC) is supplied by presenting Alamouti's scheme. The Alamouti scheme is joined with TCQ (*Classical System*) and simulated for 4-PSK modulation in Rayleigh channels (fading channels). Furthermore, the Bit Error Rate (BER), Frame Error Rate (FER) and distortion performance results are presented for the *Classical System*.

The proposed joint structure involving Alamouti code, TCQ and RSC  $(1,5/7)_{\text{Octal}}$  (*Triple Component system*) is simulated in Rayleigh channel for 4-PSK modulation and the BER, FER and distortion results are obtained and compared to the *Classical System*. The second scheme (*Triple Component system*) is designed to improve the system performance. This system shows significant performance improvement in terms of BER, FER, and Distortion criteria than the *Classical System*.

Final scheme (*Dual Component system*) is developed to take the advantage of both previous schemes (*Classical System*, *Triple Components system*). This system takes the advantage of iterative decoding facility from the second scheme (*Triple Component system*), which shows better performance. And the third scheme (*Dual Component system*) takes the advantage of the first scheme (*Classical System*) which use the same frame length (Rate of the System is equal to  $1/2$ ). That means the third scheme is less costly and has less processing time when compared to the second scheme (*Triple Component system*).

For future work, nonuniform quantizers employing trellis coding logic, i.e., non-uniform trellis coded quantizers, can be considered. These type of quantizers do not have fixed quantization interleavers and have better efficiency in terms of bit use per symbol quantized. It is obvious that future communication systems will all employ trellis based communication structures due to their superior performance. For this reason the modification of quantizers into trellis based structures is essential for these communication units to be integrated with other communication units so that joint iterative processing is possible at the receiver part for better performance.

## REFERENCES

1. **Viterbi A. J. and Omura J. K., (1974)**, “*Trellis Encoding of Memoryless Discrete Time Sources with a Fidelity Criterion*”, IEEE Transactions on Information Theory, vol. 20, no. 3, pp. 325–332.
2. **Marcellin M. W. and Fisher T. R., (1990)**, “*Trellis Coded Quantization of Memoryless and Gauss-Markov Sources*”, IEEE Transactions on Communications, vol. 38, no. 1, pp. 82–93.
3. **Ungerboeck. G., (1982)**, “*Channel Coding with Multi Level/Phase Signals*”, IEEE Transactions on Information Theory, vol. 28, no. 1, pp. 55–67.
4. **Fisher T. R., Marcellin M. W., and Wang M., (1991)**, “*Trellis-Coded Vector Quantization*”, IEEE Transactions on Information Theory, vol. 37, no. 6, pp. 1551–1566.
5. **Wang H. S. and Moayeri N., (1992)**, “*Trellis Coded Vector Quantization*”, IEEE Transactions on Communications, vol. 40, no. 8, pp. 1273–1276.
6. **Taubman D. S. and Marcellin M. W., (2002)**, “*JPEG2000 Image Compression Fundamentals*”, Standard and Practice. Boston/Dordrecht/London: Kluwer Academic Publishers.
7. **Bilgin A., Sementilli P. J., and Marcellin M. W., (1999)**, “*Progressive Image Coding Using Trellis Coded Quantization*”, IEEE Transactions on Image Processing, vol. 8, no. 11, pp. 1638–1643.
8. **Wang X. and Orchard M. T., (1999)**, “*On Successively Refinable Trellis-Coded Quantization*”, IEEE Asilomar Conference on Signals, Systems, and Computers, vol. 2, 24-27, pp. 1203–1207.

9. **Wang X. and Orchard M. T., (2000)**, “*Multiple Description Coding Using Trellis Coded Quantization*”, IEEE International Conference on Image Processing, vol. 1, no. 10-13, pp. 391–394.
  
10. **Pearlman W. and Chekima A., (1984)**, “*Source Coding Bounds Using Quantizer Reproduction Levels*”, IEEE Transactions on Information Theory, vol. 30, no. 3, pp. 559– 567.
  
11. **Eyüboğlu M. V. and Forney G. D., (1993)**, “*Lattice and Trellis Quantization with Lattice- and Trellis-Bounded Codebooks – High-Rate Theory for Memoryless Sources*”, IEEE Transactions on Information Theory, vol. 39, no. 1, pp. 46–59.
  
12. **Yang L. and Fischer T. R., (1998)**, “*A New Trellis Source Code for Memoryless Sources*”, IEEE Transactions on Information Theory, vol. 44, no. 7, pp. 3056–3063.
  
13. **Laroia R. and Farvardin N., (1994)**, “*Trellis-Based Scalar-Vector Quantizer for Memoryless Sources*”, IEEE Transactions on Information Theory, vol. 40, no. 3, pp. 860–870.
  
14. **Marcellin M. W., (1994)**, “*On Entropy-Constrained Trellis Coded Quantization*”, IEEE Transactions on Communications, vol. 42, no. 1, pp. 14–16.
  
15. **Finamore W. A. and Pearlman W. A., (1980)**, “*Optimal Encoding of Discretetime Continuous-Amplitude Memoryless Sources with Finite Output Alphabets*”, IEEE Transactions on Information Theory, vol. 26, no. 2, pp. 144–155.
  
16. **Van der Vleuten R. J. and Weber J. H., (1995)**, “*Construction and Evaluation of Trellis-Coded Quantizers for Memoryless Sources*”, IEEE Transactions on Information Theory, vol. 41, no. 3, pp. 853–859.
  
17. **Eriksson T., Anderson J. B., and Goertz N., (2007)**, “*Linear Congruential Trellis Source Codes: Design and Analysis*”, IEEE Transactions on Communications, vol. 55, no. 9, pp. 1693–1701.
  
18. **Bliss D. W., Forsythe K. W., and Amanda M. C., (2005)**, “*MIMO Wireless Communication*”, Lincoln Laboratory Journal, vol.15, no.1, pp. 97-123.

19. **Ungerboeck G., (1982)**, “*Channel Coding with Multilevel/Phase Signals*”, IEEE Transactions on Information Theory, vol. 28, pp. 55-67.
20. **Ungerboeck G., (1987)**, “*Trellis-Coded Modulation with Redundant Signal Sets, Parts I And II*”, IEEE Communication Magazine, vol. 25, pp. 5–21.
21. **Marcellin M. W. and Fischer T. R., (1990)**, “*Trellis Coded Quantization of Memoryless and Gauss-Markov Sources*”, IEEE Transactions on Communications, vol. 38, no. 1, pp. 82–93.
22. **Forney G. D., (1973)**, “*Jr. The Viterbi Algorithm*”, IEEE Communication, vol. 61, no. 3, pp. 268–278.
23. **William E. R., (2001)**, “*Concatenated Convolutional Codes and Iterative Decoding*”, University Arizona.
24. **Tarokh V., Seshadri N., and Calderbank A., (1999)**, “*Space-Time Block Codes from Orthogonal Designs*”, IEEE Transactions on Information Theory, vol. 45, pp. 1456–1467.
25. **Alamouti S., (1998)**, “*A Simple Transmit Diversity Technique for Wireless Communications*”, IEEE Journal on Selected Areas in Communications, vol. 16, pp. 1451–1458.
26. **Fragouli C., Al-Dhahir N., and Turin W., (2003)**, “*Training-Based Channel Estimation for Multiple-Antenna Broadband Transmissions*”, IEEE Transactions on Wireless Communications, vol. 2, no. 2, pp. 384–391.
27. **Marcelo M. C., Garcia-Luna-Aceves J. J., (2006)**, “*Analytical Modelling of Ad-Hoc Networks That Utilize Space Time Coding*”, 4th International Symposium on Ad-Hoc and Wireless Networks, IEEE, pp. 1–11.
28. **Gesbert D., Shafi M., Shiu D., Smith P. J., and Ayman N., (2003)**, “*From Theory to Practice: An Overview of MIMO Space-Time Coded Wireless Systems*”, IEEE Journal on Selected Areas in Communications, vol. 21, no. 3, pp. 281–302.

## APPENDICES A

### CURRICULUM VITAE

#### PERSONAL INFORMATION

**Surname, Name:** AL-SAMMARRIE, Samir H.Salih

**Date and Place of Birth:** 1 July 1954, Baghdad / Iraq

**Country of Origin:** Iraq

**Marital Status:** Married

**Phone 1:** +90 536 071 44 76

**Phone 2:** +964 770 297 72 27

**Email 1:** [samir\\_alsam@yahoo.com](mailto:samir_alsam@yahoo.com)

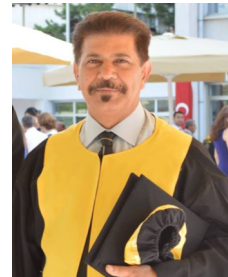

#### EDUCATION

Degree	Institution and the location	Year of Graduation
M.Sc.	Çankaya University, Electronic and Communication Engineering / Ankara, Turkey	2015
B.Sc.	University of Teqnoloji, Electronic Engineering / Baghdad, Iraq	1980
High School	Mohemet soliman / Baghdad, Iraq	1976

## **WORK EXPERIENCE**

<b>Year</b>	<b>Place</b>	<b>Enrolment</b>
Six months in 1981	Testing and Maintenance of Electronic Devices, Matra Company Normandi, France	Training
Three months in 1983	Testing and Maintenance of Electronic Devices, Airospecial Company Landvisiuo, France	Training
Three months in 1988	Testing and maintenance of electronic devices, Matra company Normandi, France	Training
1981-2013	Testing and Maintenance of Special Electronic Devices, Iraq	Work

## **LANGUAGES**

Arabic: Native

English: Advanced

Turkish: Pre-Intermediate

Franch: Pre-Intermediate

## **HOBBIES**

Running, Football, Tennis, Cycling, Chess, Puzzle.