



**THE USE OF CONVOLUTIONAL PRODUCT CODES IN COOPERATIVE
COMMUNICATION SYSTEMS**

ALI SAMEER HADI

NOVEMBER 2014

**THE USE OF CONVOLUTIONAL PRODUCT CODES IN COOPERATIVE
COMMUNICATION SYSTEMS**

**A THESIS SUBMITTED TO
THE GRADUATE SCHOOL OF NATURAL AND APPLIED
SCIENCES OF
ÇANKAYA UNIVERSITY**

**BY
ALI SAMEER HADI**

**IN PARTIAL FULFILLMENT OF THE REQUIREMENTS FOR THE
DEGREE OF
MASTER OF SCIENCE
IN
THE DEPARTMENT OF
ELECTRONIC AND COMMUNICATION ENGINEERING**

NOVEMBER 2014

Title of the Thesis : **The Use of Convolutional Product Codes in Cooperative Communication Systems**

Submitted by **Ali Sameer HADI**

Approval of the Graduate School of Natural and Applied Sciences, Çankaya University.

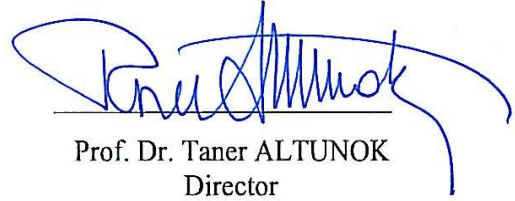
Prof. Dr. Taner ALTUNOK
Director

I certify that this thesis satisfies all the requirements as a thesis for the degree of Master of Science.

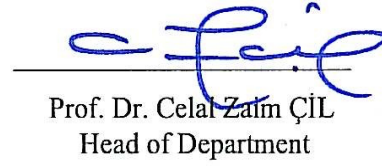
Prof. Dr. Celal Zaim ÇİL
Head of Department

This is to certify that we have read this thesis and that in our opinion it is fully adequate, in scope and quality, as a thesis for the degree of Master of Science.

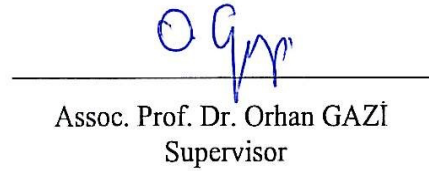
Assoc. Prof. Dr. Orhan GAZİ
Supervisor

Examination Date: 07.11.2014

Examining Committee Members

Assoc. Prof. Dr. Orhan GAZİ (Çankaya Univ.)

Assist. Prof. Dr. Reza HASSANPOUR (Çankaya Univ.)

Dr. Mehmet YÜCEER (TÜRKSAT)

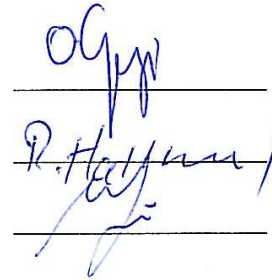

STATEMENT OF NON-PLAGIARISM PAGE

I hereby declare that all information in this document has been obtained and presented in accordance with academic rules and ethical conduct. I also declare that, as required by these rules and conduct, I have fully cited and referenced all material and results that are not original to this work.

Name, Last Name: Ali Sameer, HADI

Signature : 

Date : 07.11.2014

ABSTRACT

THE USE OF CONVOLUTIONAL PRODUCT CODES IN COOPERATIVE COMMUNICATION SYSTEMS

HADI, Ali Sameer

M.Sc., Department of Electronic and Communication Engineering

Supervisor: Assoc. Prof. Dr. Orhan GAZI

November 2014, 50 pages

In this thesis work, the performances of cooperative communication systems employing convolutional product codes (CPCs) and serially concatenated convolution codes (SCCCs) are inspected in detail and compared to each other. Different combining methods at destination are proposed. One of these methods is based on the combination of bit probabilities on the other hand other method focuses combining the signals considering their signal to noise ratios (SNRs). The effect of relay number on the system performance is inspected. Reduced complexity cooperative communication systems utilizing convolutional product codes are considered. The proposed systems are all iteratively parallel decodable and have low latency.

Keywords: Cooperative Communication Systems, Convolutional Product Codes, Iterative Decoding, Concatenated Codes and Serially Concatenated Convolutional Codes.

ÖZ

İŞBİRLİKÇİ HABERLEŞME SİSTEMLERİNDE KONVOLÜSYONEL ÜRÜN KODU KULLANIMI

HADI, Ali Sameer

Yüksek Lisans, Elektronik ve Haberleşme Mühendisliği Anabilim Dalı

Tez Yöneticisi: Doç. Dr. Orhan GAZİ

Eylül 2014, 50 sayfa

Bu tez çalışmasında konvolusyonel çarpım kodlarının işbirlikçi iletişim sistemlerine uyarlanması ve bu sistemlerdeki performanslarının incelenmesi icra edilmiştir. Elde edilen performans sonuçları seri olarak birleştirilmiş kodların işbirlikçi iletişim sistemlerine uyarlanması ile elde edilen performans sonuçları ile kıyaslanmıştır. Varış noktasında rölelerden ve kaynaktan gelen sinyalleri birleştirmek için çeşitli kaynaştırma yöntemleri kullanılmıştır. Bu yöntemlerden biri bit olasılıklarının birleştirilmesi esasına dayanırken diğeri sinyal gücünün gürültü gücüne oranı değerlerinin birleştirilmesi esasına dayanmıştır. Röle sayısının sistem performansı üzerindeki etkileri incelenmiştir. Daha düşük gecikmeli konvolusyonel çarpım kodları kullanan işbirlikçi iletişim sistemlerinin tasarımı ile ilgili çalışmalar yapılmıştır.

Anahtar Kelimeler: İşbirlikçi İletişim Sistemleri, Konvolusyonel Çarpım Kodları, Yinelemeli Çözüm, Birleşik Kodlar ve Seri Olarak Birleştirilmiş Kodlar.

ACKNOWLEDGEMENTS

I would like to thank all the former and present colleagues and friends at the Department of Electronic and Communication Engineering for the contribution of the nice and friendly atmosphere here. Specially, I would like to express my deepest gratitude to my research supervisor Assoc Prof. Dr. Orhan GAZI for providing me with the opportunity to do this interesting work and giving me invaluable expertise throughout the work. His inspiring guidance, deep knowledge and patience have been invaluable for me and very much appreciated.

Last but not least, I would like to express my most sincere gratitude and respect to my parents (Eng. Samir AL-SAMMARIE & Eng. Maiysoon ABDULAMEER), fiancée (Sama AL-ANI), brothers and sisters for the help and spiritual encouragement, and for their patience, sacrifice and understanding. Without their help it would not have been possible to complete the thesis.

Many thanks also go to my other friends, thanks all of you for your friendship.

TABLE OF CONTENTS

STATEMENT OF NON PLAGIARISM.....	iii
ABSTRACT.....	iv
ÖZ.....	v
ACKNOWLEDGEMENTS.....	vi
TABLE OF CONTENTS.....	vii
LIST OF FIGURES.....	x
LIST OF TABLES.....	xii
LIST OF ABBREVIATIONS.....	xiii

CHAPTERS:

1. INTRODUCTION.....	1
1.1. Fundamental Concepts in Cooperative Communications.....	3
1.2. Background Information on Cooperative Communications	3
1.3. Relaying Protocols: Processing Modes at Relays.....	4
1.3.1. Decode-and-forward: regenerative relay.....	4
1.3.2. Amplify and forward: non-regenerative relay.....	5
1.3.3. Compress and forward and estimate and forward.....	6
1.3.4. Coded cooperation.....	6
1.4. Relaying Combining Strategy for Cooperative Communications.	6
1.5. One Way and Two Way Relays.....	7
1.6. Multi hop Relay Networks.....	8
1.7. Objectives.....	9
1.8. Organization of the Thesis.....	9
2. CONCATENATED CODES.....	10
2.1. Concatenation of Codes.....	10
2.2. Recursive Systematic Convolutional Codes (RSC).....	11

viii

2.3.	Trellis Termination.....	13
2.4.	Semirandom Interleaver (S-R Interleaver)	14
2.5.	Parallel Concatenated Convolutional Code (PCCC)	14
2.5.1.	PCCC encoder and decoder.....	14
2.5.2.	The MAP algorithm.....	18
2.5.3.	The Log-MAP algorithm and Max-Log-MAP algorithm.....	19
2.6.	Serial Concatenated Convolutional Code (SCCC)	21
2.6.1.	SCCC encoder.....	21
2.6.2.	SCCC decoder.....	22
2.7.	Convolutional Product Codes (CPC)	23
3.	The USE OF CPCs IN COOPERATIVE COMMUNICATION SYSTEMS.....	25
3.1.	The Cooperation Channel Code Form.....	25
3.1.1.	Maximal ratio combining (MRC) method.....	26
3.1.2.	Individual decoding method (IDM)	27
3.2.	SCCC in Cooperative Communication.....	28
3.2.1.	Full encoding in relays (Classical Method)	28
3.2.2.	<i>Soft Decoding with Half Hard Decision in Relays</i>	30
3.2.3.	<i>Soft Decoding with Full Hard Decision in Relays</i>	32
3.3.	Using CPCs in Cooperative Communication.....	33
4.	SIMULATION RESULTS.....	36
4.1.	General Information About the Results.....	36
4.2.	PCCC Simulation Results.....	36
4.3.	SCCC Simulation Results.....	37
4.4.	CPC Simulation Results.....	38
4.5.	SCCC in Cooperative Channel Coding.....	40
4.5.1.	Full encoding case.....	40

4.5.2.	Simulations for <i>Soft Decoding with Half Hard Decision</i> <i>in Relays</i>	41
4.5.3.	Without encoding in the relays.....	42
4.6.	Using Individual Decoding Method (IDM) for Cooperative Communication Systems Employing SCCCs.....	44
4.6.1.	Decoding with and without sharing the a-priori information.....	44
4.6.2.	Sharing the a-priori between the signals over fading channels.....	45
4.7.	CPC in Cooperative Channel Coding.....	47
5.	CONCLUSION AND FUTURE WORK.....	49
5.1.	Conclusion.....	49
5.2.	Future Work.....	50
	REFERENCES.....	R1
	APPENDICES.....	A1
A.	CURRICULUM VITAE.....	A1

LIST OF FIGURES

FIGURES

Figure 1	Cooperative communications system with one relay.....	4
Figure 2	Basic model of a two way relay system.....	8
Figure 3	Serial concatenated code.....	10
Figure 4	Parallel concatenated code.....	11
Figure 5	Non-Systematic convolutional encoder with $r = 1/2$	12
Figure 6	The RSC encoder structure, $r=1/2$ and $K=3$	12
Figure 7	State diagram for RSC encoder.....	13
Figure 8	PCCC encoder structure, L corresponding to the length.....	15
Figure 9	Iterative PCCC decoding structure.....	16
Figure 10	SCCC encoder diagram with RSC compound code and S-R Interleaver.....	21
Figure 11	SCCC decoder diagram.....	22
Figure 12	CPC encoder and decoder diagram.....	24
Figure 13	Base structure of the cooperation channel code.....	26
Figure 14	Decoding and encoding operation at the relays.....	29
Figure 15	Relay structure of <i>Soft Decoding with Half Hard Decision in Relays</i>	31
Figure 16	Relay structure of <i>Soft Decoding with Full Hard Decision in Relays</i>	33
Figure 17	CPC in cooperative communication.....	34

FIGURES

Figure 18	PCCC Bit Error Rate (BER) and Frame Error Rate (FER) simulation results.....	37
Figure 19	SCCC Bit Error Rate (BER) and Frame Error Rate (FER) simulation results.....	38
Figure 20	CPC Bit Error Rate (BER) and Frame Error Rate (FER) simulation results with m=4 rows.....	39
Figure 21	CPC Bit Error Rate (BER) and Frame Error Rate (FER) simulation results with m=8 rows.....	39
Figure 22	SCCC BER performance for relay communication systems, Full Encoding Decoding operation are performed in relays.....	40
Figure 23	Comparison between <i>Soft Decoding with Half Hard Decision in Relays</i> and <i>Classical Method</i> using MRC, Bit Error Rate (BER) simulation results are depicted.....	41
Figure 24	SCCC in cooperative communication with 3-Relays comparison among MRC and IDM methods, Bit Error Rate (BER) simulation results are depicted.....	43
Figure 25	SCCC in cooperative communication with 4-Relays Using MRC and IDM methods, Bit Error Rate (BER) simulation results are displayed.....	44
Figure 26	SCCC in cooperative communication using IDM method, <i>Soft Decoding with Full Encoding in Relays</i> , With and Without Sharing the A-priori, Bit Error Rate (BER) simulation results...	45
Figure 27	SCCC in cooperative communication using IDM method, <i>Soft Decoding with Full Encoding in Relays</i> , over fading channels, Bit Error Rate (BER) simulation results.....	46
Figure 28	SCCC in cooperative communication using IDM method, <i>Soft Decoding with Full Encoding in Relays</i> , over fading channel, Frame Error Rate (FER) simulation results.....	47
Figure 29	Bit Error Rate (BER) simulation results for SCCC, CPC-4 rows and CPC-8 rows. MRC is used at the destination.....	48

LIST OF TABLES

TABLES

Table 1	Comparison Between <i>Classical Method</i> , <i>Half Hard Decision</i> , <i>Full Hard Decision</i> and CPC in Cooperative Communication	35
----------------	--------------------------------------------------------------------------------------------------------------------------------------------	----

LIST OF ABBREVIATIONS

ECC	Error Control Coding
SNR	Signal To Noise Ratio
MAP	Maximum A Posteriori
CPC	Convolutional Product Code
PCCC	Parallel Concatenated Convolutional Code
SCCC	Serial Concatenated Convolutional Code
BW	Band Width
AWGN	Additive White Gaussian Noise
APP	A Posteriori Probability
LLR	Long-Likelihood Ratio
RSC	Recursive Systematic Convolutional
B-PSK	Binary Phase Shift Key
MIMO	Multiple Input Multiple Output
SPK	Single Parity Check
SISO	Soft Input Soft Output
DF	Decode-and- Forward
AF	Amplify-and-Forward
HDAF	Hybrid Decode Amplify Forward
CF	Compress-and-Forward
EF	Estimate-and Forward
CSI	Channel State Information
MMSE	Minimum Mean Square Error
MRC	Maximum Ratio Combining
IDM	Individual Decoding Method
HHDE	Soft Decoding with Half Hard Decision Encoding in Relays
FHDE	Soft Decoding with Full Hard Decision Encoding in Relays
ML	Maximum Likelihood
DSSC	Distributed Switch-and-Stay Combining
BRS	Best Relay Selection

CHAPTER 1

INTRODUCTION

Wireless communications has gained much popularity in the last century and many new products for wireless communication systems are released with the spread of services such as mobile multimedia, mobile video applications, and mobile streaming on-demand. People are seeking methods for higher data rates in the third-generation (3G) mobile cellular systems and this tendency grows more for 4G systems.

The main idea of using cooperation is that of resource sharing within diverse nodes in a cooperation network. The reason over the exploration of user cooperation is able to share power and computation with neighbouring relay nodes. And, that may lead to the saving total resources. Mesh networks gives a huge application area for user cooperation strategies to be performed.

Half-duplex relaying has been considered as a practical form of relaying that has possibility of different applications in near future.

Multiple Input Multiple Output (MIMO) systems, where the use of multiple antennas provided at the transceiver of the wireless link raise the data rate and reliability of wireless networks [1–6]. As one of the most important research themes of wireless communications, space-time coding has been evolved to reach the information theoretical limit of MIMO channels. Besides, using multiple antennas also enhances the spatial diversity gain compared to a single antenna system. However, MIMO systems accuracy depends on the high spreading propagation environment of wireless communications. Performance of MIMO systems is restricted by both the spatial fading correlation of antennas and rank deficiency of the channel. Spatial fading correlation between the antennas which is co-located at one side minimizes

the diversity gain, while rank deficiency occurs due to double spread or pinhole effects of multiple antenna channels. These reasons cause reducing the spatial multiplexing gain in MIMO systems [7–10].

The three-terminal wireless system has been suggested to take advantage of MIMO's. If two terminals want to communicate with each other and the link among them is too weak, then the third terminal will perform as a relay to help the direct communication. With this setup, the correlation effect caused by multiple co-located antennas can be reduced. Moreover, the destination can join the signals from source and relay terminals to earn spatial diversity gain. It has been proved that such cooperative communication is a powerful technique to increase the capacity and reliability of the communication systems, and finally extends the transmission coverage area [11].

Different from non-real-time data such as file-transfer, multimedia applications have a strict delay bonds including real-time delivery. In the video streaming scenario, for instance, even a correctly decoded packet at the direction can be considered as out-dated if its arrival time is later than some predefined bonds. Furthermore, for multimedia services, e.g., image and video, some sections of the encoded bit-stream require higher priority of saving than others. The corrupting high priority data can remarkably decrease the performance of the whole image or video. These properties form the multimedia transferring over time alternative fading channels a huge challenge. Recently, it has been proved that using relays is a promising way to increase the performance of multimedia transmission.

Briefly, this introduction shows the province of cooperative communications and its applications to mobile multimedia as well as supplies the reader a general view on the assistance of the thesis. What will come in this chapter is the introducing of cooperative communications. First of all, providing a short review of major work in this area and then going on with the background of cooperative communications. There are some main concepts of relaying like relaying protocols, relaying combining and strategies, which are further discussed. In addition, other substitution aspects expanded from conventional cooperative communications, e.g., two-way relay networks and multi-hop relay communications, are discussed.

1.1 Fundamental Concepts in Cooperative Communications

One of the earliest studies in cooperative communication is done in [12] in 1970's, where the ability of relay channels was studied for the issue of information transferring through three terminals. Then the channel ability of relay networks over non-faded channel has been tested in [13]. The relaying concept has obtained perfect attention in recent years and studied for fading channels in [14–23]. The relay networks through Rayleigh fading channels have been searched in [14–16]. The diversity-multiplexing trade-off of DF and AF relays has been studied in [17, 18]. Some distributed space-time codes for relay networks have been suggested in [17, 21]. User cooperation, which is the popularization of relay networks to multiple sources, has been investigated in [19, 20]. Capacity studies for relaying/cooperation have been inspected in [22, 23]. Although the issues of relaying and cooperation have been thoughtful for a long time in many aspects such as communications, signal processing, networking, and information theory, it still attracts the research community. Recently, cooperative communication has been included in WiMAX standard and is prospected to dispersal into many other commercial standards [24].

1.2 Background Information on Cooperative Communications

The concept of cooperative communications is to profiteer the broadcast nature of wireless networks where the contiguous nodes overhear the source's signals and relay the information to the destination. As can be seen from Fig. 1, after receiving the signals resulting from the source, a third-party terminal called relays forward their overhearing information to the destination so as to raise the capacity and/or upgrade reliability of the direct communication. The end-to-end transmission is obviously divided into two separate steps in the time area: Broadcasting and relaying phase. In the broadcasting phase, i.e., broadcasting channel as seen from the source's point of view, all the receiving terminals including the relays and destination work in the same slot time of frequency as opposed to the second stage. In the relaying phase, i.e., multiple access channels as seen from the destination's viewpoint, the transmitting terminals (relay nodes) may work in different channels to avoid co-

channel involvement.

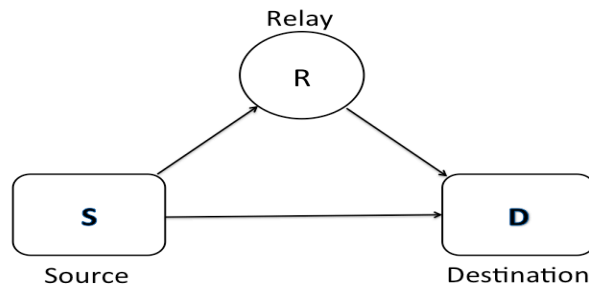

Figure 1 Cooperative communications system with one relay

1.3 Relaying Protocols: Processing Modes at Relays

After the critical aspect of cooperative communications time to write about the relay processing of the source's signals. This aspect is called relaying protocol or processing mode at relays. In general, relaying protocols are categorized in two classes: decode and- forward (DF) and amplify-and-forward (AF). A hybrid scheme combining DF and AF called hybrid decode amplify forward (HDAF), which takes the advantage of both conventional modes. Besides these two important relaying protocols, other techniques such as compress-and-forward (CF), estimate-and forward (EF), and coded cooperation are used in cooperative communication.

1.3.1 Decode-and-forward: regenerative relay

This relaying protocol is one of the earliest methods of classical cooperative communications. Using the regenerative way, the relays decipher the source's message and re-encode it before sending to the destination. In this approach the relays are helpful in communications if the signal from the source is correctly decoded [25, 26]. This can be understood by a cyclic redundancy check (CRC) code. With this tight supposition on the perfect ability of decoding by CRC, the relay can be rated as adaptive DF. But, in practice, it is not always possible for the relay to recover the data perfectly if the source's signal received is not good. By relaxing the

above supposition, another model of DF relays, namely fixed DF, has been extensively mentioned in [27–30]. Under fixed DF mode, the relay always sends the decoded message to the destination in any case of the goodness of received signals. It has been proved that the instantaneous received signal-to-noise ratio (SNR) is nearly approached as the minimum SNR between two hops. Furthermore, the conventional adaptive DF protocol is restricted because of the decision time is fixed a priori. When the channel goodness of the source-to-relay connection is powerful, the relay is going to be fit to decode very fast. As a consequence, the delaying until half-time before the relay can transfer that will lead to waste some of resource. The dynamic DF protocol, mentioned in [31, 32] where the decision time is randomly changing that can get disadvantage to the adaptive DF scheme.

1.3.2 Amplify and forward: non-regenerative relay

In non-regenerative system, the signal is amplified and transmitted, no decoding operation is performed. The relay multiplies the noisy signal with the amplifying factor under a certain limitation, e.g., power limitation, and then transfers the processing signal to the destination. As the relay simply retransfers the received signal from the source without any decoding manipulation, the non-regenerative method minimizes the hardware complexity of relay compared to its equivalent of DF.

This method has been suggested first by Laneman et al [18]. The noisy signal is amplified by the relay; and the cooperation has been made at the destination by joining two independently faded signals resulting from source and relay. The second order diversity is investigated of this system is investigated in [18, 33]. The factor of the amplifying gain leads to further subcategories of AF relays. If the relay has the full knowledge of the channel state information (CSI), the amplifying gain can be diversified and its name is CSI-assisted AF relay or variable-gain AF relay. In contrast, the semi-blind AF relay or fixed gain AF relay requires only the statistical property for the channel between sources to relay. The previous outperforms the latter in terms of the error-rate performance with the raised complexity [34]. Hence, there is a trade-off between the two versions of AF relays.

1.3.3 Compress and forward and estimate and forward

Other relaying techniques without requirement of decoding at the relay are CF [35] and EF [36, 37]. The key idea of CF is that the relay quantizes and compresses the received signal using lossy source coding methods and transmits it. Then, the destination receives the message from the source and its quantized/compressed version from the relay. In EF mode, the relay forwards an analog estimate of the transmitted signals. The estimation can be performed by entropy constrained scalar quantization of the received signal [36] or by an unconstrained minimum mean square error (MMSE) scheme [37]. It has been shown that the performance of CF and EF in terms of achievable rates is better than DF when the relay is close to the destination and vice versa.

1.3.4 Coded cooperation

Coded cooperation is different from above relaying strategies. It integrates channel coding into cooperation [38–40]. Each user's data is divided into two segments, i.e., a codeword is divided into two parts. For the first phase, each user transmits the first part of its own codeword and attempts to decode the other received from the corresponding communication partner. If the signal is decoded successfully, which is specified by the CRC, the user will create the rest part of its partner's code word and transfer it to the destination. Otherwise, the user transfers its own second part. It is essential to bear in mind that the user and its matching communication partner work over orthogonal channels. In general, several channel coding schemes can be used for coded cooperation like block or convolutional code or a combination of both.

1.4 Relaying Combining Strategy for Cooperative Communications

Maximum ratio combining (MRC) is a very widely used technique to combine all the received signals from source and relays based on the supposition that the destination has the knowledge of CSI. A new version of MRC for relay channels has been suggested in [27], names as cooperative-MRC (C-MRC). This new approach has

been seen to achieve the full variety gain regardless of the constellation used. However, use of MRC or C-MRC at the destination requires the full knowledge of CSI for all links, which is difficult to accomplish in practical scenarios. To fulfil the full variety while keeping the complexity acceptable, a distributed switch-and-stay combining (DSSC) has been investigated in [41-43].

The destination compares the received signals in quality, i.e., received instantaneous SNR, with the predetermined threshold and makes the decision to switch section between source and relay. This scheme works similarly as incremental relaying without applying MRC among two sections. Best relay selection (BRS) has been counted as one of the simplest relaying linking strategies achieving the full diversity [25, 26, 28–30, 44, 45]. The BRS technique can be divided into relay where the relay holding the maximum of the minimum SNR between two hops. These hops are chosen the best relay where the relay has the largest global received SNR. Similarly, as in C-MRC, again the destination is suggested to have the good CSI for making the decision to choose the best relay to make it reliable. A simpler version of BRS, called partial relay selection (PRS), has been suggested to take the place of the previous proposition [46–53]. In contrast, only the CSI of the second hop is taken for relay selection. Although, this scheme displays a weak role compared to its equivalent BRS, its low complexity is created and attractive for practical achievement.

1.5 One Way and Two Way Relays

Half-duplex relay network connections waste 50% of the throughput with respect to full-duplex (Dual-hop), this means that the relay cannot transfer and receive at the same time. To get over this obstacle, a dual-hop (or bidirectional) relay network is proposed in [56], where two relay nodes, S1 and S2, transfer at the same time to the relay node R in the first hop and in the second hop the relay node R forwards its received signals to both stations S1 and S2. With this way, this waste of throughput can be signally repaid. As a result, two-way relay networks have obtained good noticing in the research community as shown in Fig. 2 (e.g., see [56–60]).

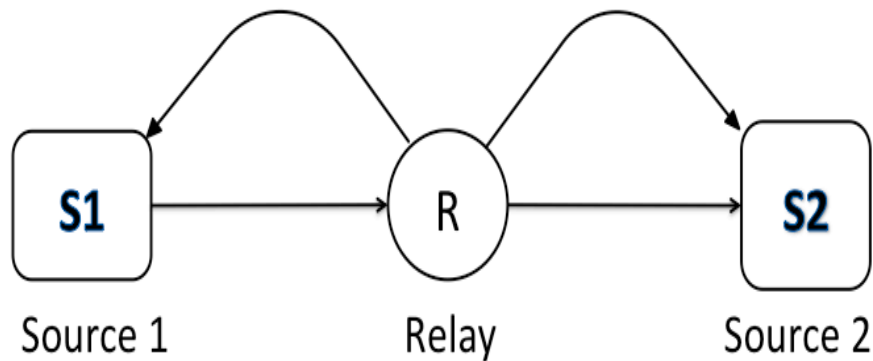

Figure 2 Basic model of a two way relay system

1.6 Multi hop Relay Networks

The multi hop communication in relay networks is a very significant approach to develop the transferring coverage of cellular and ad hoc networks [61–66].

In multi-hop relay networks, there are more than one relay between transmitter and receiver. Multi-hop transmission can obviously decrease the transfer power compared to direct communication. In addition, because of transfer power bonds; multi-hop transmission also leads to remarkable coverage expanding by dividing a total end-to-end transferring into a group of shorter ways. On the other hand, due to the restrict effect of fading and shadowing, the shortage of line-of-sight can strictly degrade. Using multi-hop transmission can get over these dead-end spots issues and thus another benefit of multi-hop relaying has been mentioned, especially for countryside with low traffic density population. As the consequence, the multi-hop technique is a hopefully one to meet the desirable target of modern wireless systems with respect to providing seamless communications [67].

1.7 Objectives

The aim of studying cooperation channel codes is to decrease the latency in the relay nodes especially and in the entire system generally, with respect to have a powerful system performance. In addition, proving that the cooperation channel codes can be implemented and used successfully in wireless communication systems. We suggest several ideas to decrease the system latency, as we will explain it in Chapter three. However, such a subject is a huge field; we will concentrate our study on using SCCC and CPC in cooperation channel networks and present the system manner when the number of relay nodes is increasing.

1.8 Organization of the Thesis

This thesis contains five chapters. All the important information about the cooperative channel code systems, methods used in channel coding to detect and correct the errors and numerical analysis of these fields can be founded for different geometries.

Chapter 1 is an introduction, a brief review on fundamental research work of cooperative communications, basic background on cooperative communications, review some types of relays and the purposes of this thesis.

Chapter 2 describes and shows the equation and structures for that are used in Parallel Concatenated Convolutional Code (PCCC), Serial Concatenated Convolutional Code (SCCC) and Convolutional Product Code (CPC) which can be used in cooperative systems.

In Chapter 3, SCCC and CPC are used in cooperative communication systems and we proposed some methods to decrease the latency in the relay nodes and increase the system performance.

In Chapter 4, simulation results are presented.

Chapter 5 includes the conclusion part and future works.

CHAPTER 2

CONCATENATED CODES

2.1 Concatenation of Codes

A concatenated code consists of at least two component codes connected in such a way to create a better code. Concatenation can be achieved via two methods which are called serial and parallel concatenation. In Fig. 3 serial concatenation procedure is described.

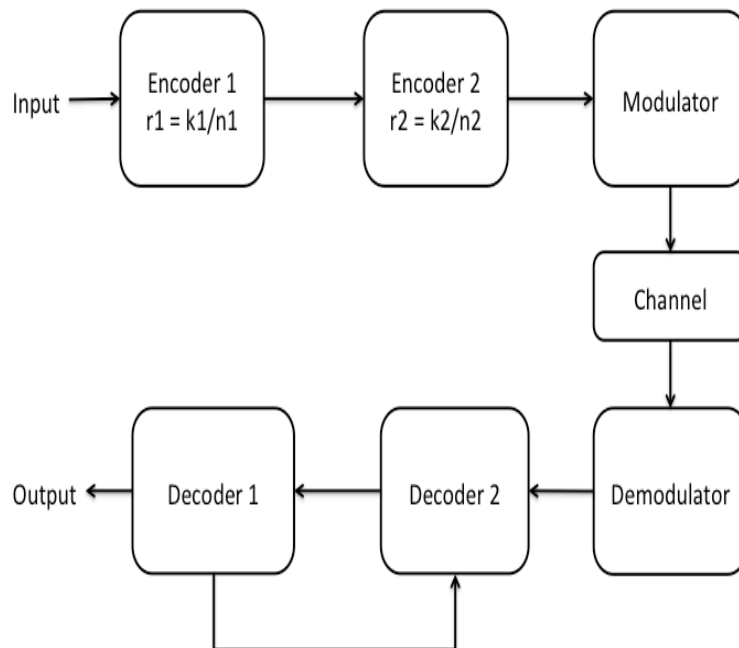

Figure 3 Serial concatenated code

Referring to Fig. 3, the overall code rate for serial concatenation can be written as

$$r_{total} = \frac{k_1 k_2}{n_1 n_2} \quad (2.1)$$

In Fig. 4 parallel concatenation procedure is illustrated.

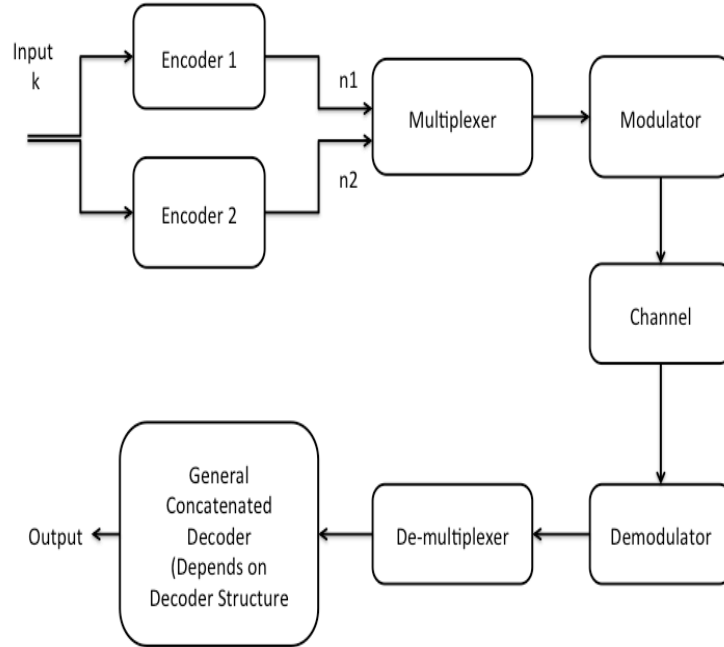

Figure 4 Parallel concatenated code.

The overall code rate for parallel concatenation is

$$r_{total} = \frac{k}{n_1 + n_2} \quad (2.2)$$

2.2 Recursive Systematic Convolutional Code (RSC)

The recursive systematic convolutional (RSC) encoder is obtained from the non-recursive non-systematic convolutional encoder by feeding back one of its encoded outputs to its input. Figure 5 shows a non-systematic convolutional encoder.

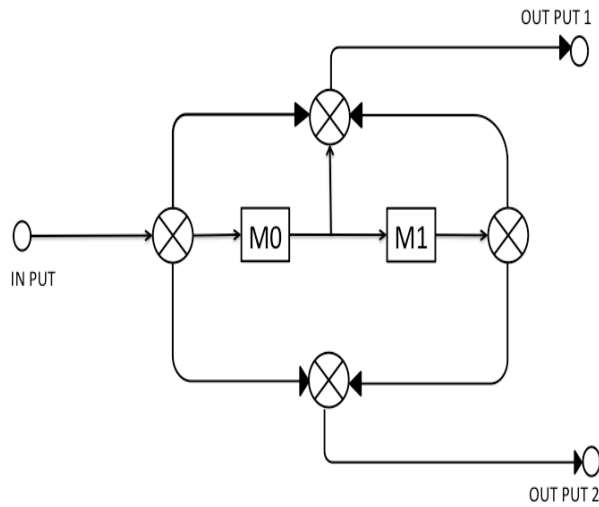

Figure 5 Non-Systematic convolutional encoder with $r = \frac{1}{2}$

The non-systematic convolutional encoder is illustrated by the dynamo series $g_1 = [111]$ and $g_2 = [101]$ and can be equivalently combined into one matrix expression as $G = [g_1, g_2]$. The RSC encoder of this non-systematic convolutional encoder is indicated by $G = [1, g_2 / g_1]$ where the numerator term (referred to as g_1) describes the feedback path directly to the input. In Fig. 6 the structure of RSC encoder is described.

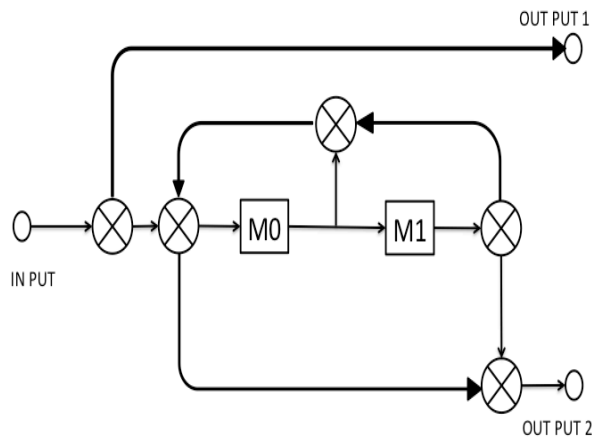

Figure 6 The RSC encoder structure, $r=1/2$ and $K=3$

It is known that the perfect codes could be gained by synchronizing the feedback of the RSC encoder to a primal polynomial which creates extreme-extended series.

2.3 Trellis Termination

For the trellis termination of non-recursive convolutional encoder information sequences are padded by $m=K-1$ zero. These extra bits lead the convolutional encoder to go to the all-zero state (trellis termination). But, this way is not thinkable for the RSC encoder due to the feedback. The trellis termination bits for RSCs are decided regarding the last state of the trellis diagram. The trellis termination bits of the lower component code of RSC are different from that of the first component code if different RSC encoder or interleaver is used. In the Fig. 7, the state diagram, it is seen that zero state can be reached from any state with a maximum of two transitions. To achieve trellis termination, it is sufficient to end any data stream by two termination bits which results in four bits (two data bits and two parity bits) after encoding operation.

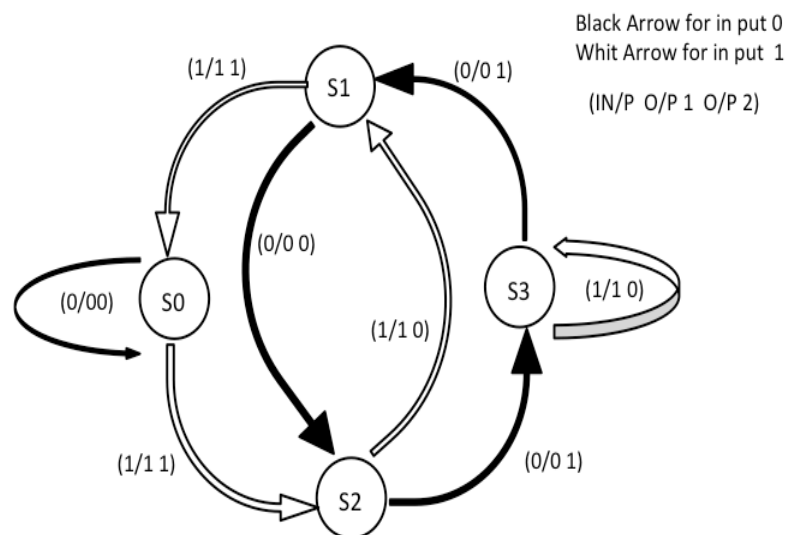

Figure 7 State diagram for RSC encoder

2.4 Semirandom Interleaver (S-Random Interleaver)

The semirandom interleaver is the one between a random interleaver and an “algebraic” interleaver. The construction of S-Random interleaver is explained as below:

Stage 1. Pick a random integer $i \in [0, L - 1]$.

Stage 2. Choose a positive number (integer) $S < \sqrt{\frac{L}{2}}$.

Stage 3. Pick another integer $j \in [0, L - 1]$ such that $|i-j| < S$, and this comparison should be satisfied between i and $S-1$ previously chosen integers (j).

Stage 4. Go to Stage 1 until all the integers are selected from the vector $[0, L - 1]$.

2.5 Parallel Concatenated Convolutional Code (PCCC)

2.5.1 PCCC encoder and decoder

A general structure of PCCC encoder employing two Recursive Systematic Convolutional (RSC) encoders is shown in Fig. 8. RSC encoders produce excessive information which is parity bits. The information and parity bit streams are multiplexed and transmitted. An interleaver is employed in front of the one of the component encoders.

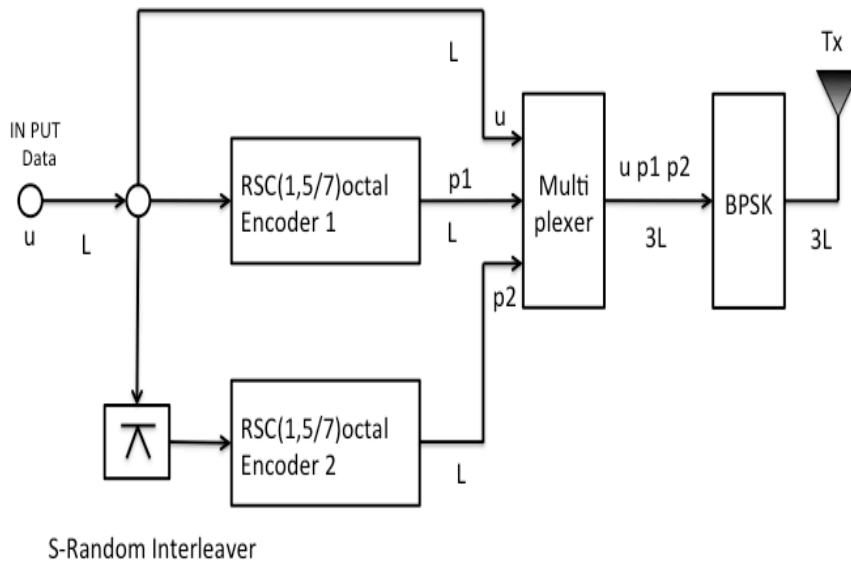

Figure 8 PCCC encoder structure, L is the information frame length

The interleaver is the major section of PCCC encoder. Interleaver reduces the correlation between codewords produced by component encoders. This situation is the opposite of non-recursive counterparts; RCS encoders can only be terminated by certain terminating data sequences. Researchers investigated the role of the interleavers in code performance and found that good interleaver design is essential for the good performance of the concatenated code [68].

The performance improvement due to the use of a well-designed interleaver is named as the interleaver gain [69].

The interleaver also affects the PCCC decoder performance by decreasing the correlations degree between the soft-output of every decoder, which turns into the external data to the next decoder (Decoder1 & Decoder2 in Fig. 9). As the correlations degree reduces between dual softs data, the performance of PCCC decoder increases [70].

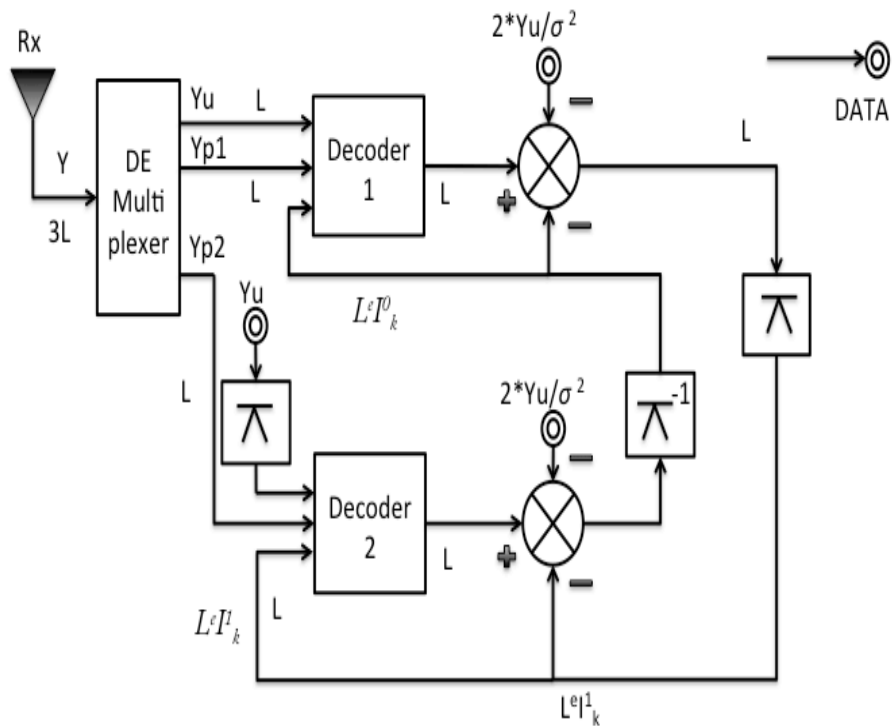

Figure 9 Iterative PCCC decoding structure

In PCCC decoding system (see Fig. 9), two decoders work iteratively and exchange information at every iteration. These decoders produce and exchange soft outputs-. A decoder like this is named as a Soft-Input Soft- Output (SISO) decoder [71].

Every decoder does not work only by input itself, but also it works with the second decoder's imperfectly decoded output, which looks like the process basis of PCCC engines. This operation between the process of the PCCC decoders and the PCCC engine is called "Turbo codes" [72].

PCCC decoding procedure could be described as follows: Encoded data series X_k is transferred through an Additive White Gaussian Noise (AWGN) channel, and a noisy received sequence Y_k is obtained. Every decoder is find the Log-Likelihood Ratio (LLR) for the k -th information bit u_k , as

$$L(u_k) = \log \left[\frac{P(u_k=1|Y)}{P(u_k=0|Y)} \right] \quad (2.3)$$

LLR can be decomposed into 3 independent terms, as

$$L(u_k) = L_{apri} + L_c(u_k) + L_e(u_k) \quad (2.4)$$

where $L_{apri}(u_k)$ is the a-priori data of u_k , $L_c(X_k)$ is the channel area, and $L_e(u_k)$ is the external data exchanged between the essential decoders. External data from a decoder become the a-priori data for the next decoder at the following decoding stage.

L_{e12} and L_{e21} in Fig. 9 shows the external data from decoder 1 to decoder 2 and decoder 2 to decoder 1 continuously. For the decoding of PCCCs SOVA and MAP algorithm can be used for the calculation of LLRs. The SOVA seeks for the most probably path through the encoder trellis. In contrast, the MAP algorithm seeks for the most probably information sequence. The MAP algorithm is a very complicated algorithm compared to SOVA. The performance of SOVA and MAP are mostly the same at high SNR. But, MAP algorithm is better than SOVA by 0.5 dB or more in the low Signal-to-Noise Ratios [71]. In the next part of this chapter the MAP algorithm and its clarified editions Log-MAP and Max-Log-MAP algorithms are explained.

2.5.2 The MAP algorithm

The MAP algorithm is a popular algorithm used in iterative decoding of concatenated codes. It has huge amount of mathematical computation which makes its application difficult for practical systems. The Log-MAP and Max-Log-MAP algorithms are modified version of the MAP algorithm [73] for ease of implementation.

MAP algorithm computes LLRs for each data bit as

$$L(u_k) = \ln \left[\frac{\sum_{S_k} \sum_{S_{k-1}} \gamma^1(S_{k-1}, S_k) * \alpha(S_{k-1}) * \beta(S_k)}{\sum_{S_k} \sum_{S_{k-1}} \gamma^0(S_{k-1}, S_k) * \alpha(S_{k-1}) * \beta(S_k)} \right] \quad (2.5)$$

where α is the forward state probability, β is the backward state probability, γ is the branch metric, S_k denoted the state at time instant k , and S_{k-1} is the trellis state at time instant $k-1$. Recursive computation of forward state metrics can be done using: $\alpha_k(S_k) = \sum_{S_{k-1}} \gamma_k^i(S_{k-1}, S_k) * \alpha_{k-1}(S_{k-1})$ (2.6)

Similarly, the backward state metrics are recursively computed as follows:

$$\beta_{k-1}(S_{k-1}) = \sum_{S_k} \beta_k(S_k) * \gamma_k^i(S_{k-1}, S_k) \quad (2.7)$$

Branch metrics are computed for every allowable state transitions as

$$\gamma_k(S_{k-1}, S_k) = P(u_k) * P(y_k | c_k) \quad (2.8)$$

where the initial values for a-priori probabilities are $P(u_k=1)=1/2$ and $P(u_k=0)=1/2$, and

$$\gamma_k^i(S_{k-1}, S_k) = P(u_k) * \left(\frac{1}{2 * \pi * \sigma^2} \right) * e^{((\frac{-1}{2 * \sigma^2}) * ((y_k^1 - c_k^1)^2 + (y_k^2 - c_k^2)^2))} \quad (2.9)$$

where i can be either 0 or 1, c_k^1 and c_k^2 are the information and parity bits, and, y_k^1 and y_k^2 are the noisy received signals.

Initial values for the forward and backward state metrics are set as:

$$\alpha_0(S_0) = \begin{cases} 1 & S = 0 \\ 0 & \text{other wise} \end{cases}$$

$$\beta_N(S_N) = \begin{cases} \frac{1}{4} & \text{for every } S \end{cases}$$

The a-posteriori probabilities for the information bits are computed as:

$$P(u_k = 1|y_k) = \sum_{u_k=1} (\alpha_{k-1}(S_{k-1}) * \gamma_k^1(S_{k-1}, S_k) * \beta_k(S_k)) \quad (2.10)$$

$$P(u_k = 0|y_k) = \sum_{u_k=0} (\alpha_{k-1}(S_{k-1}) * \gamma_k^0(S_{k-1}, S_k) * \beta_k(S_k)) \quad (2.11)$$

And the LLRs for every data bit is computed via

$$L(u_k) = \frac{p(u_k = 1|y_k)}{p(u_k = 0|y_k)} \quad (2.12)$$

After a sufficient number of iterations, the decision on the transmitted bit is done using

$$u_k = \begin{cases} 0 & L(u_k) < 1 \\ 1 & L(u_k) > 1 \end{cases}$$

2.5.3 The Log-MAP and Max-Log-MAP algorithm

For practical implementation of the MAP algorithm two versions of it which are Log-MAP and Max-Log-MAP are suggested by researchers. The suggested algorithms avoid overflow cases which appears in the computation of forward and backward state metrics. Lets start with the following property

$$\text{Max}^*(X, Y) \cong \log(e^x + e^y) = \text{Max}(x, y) + \log(1 + e^{-|y-x|}) \quad (2.13)$$

In logarithmic domain and using the Max* operation the (2.6) and (2.7) are written as

$$\alpha_k(S_k) = \ln(\sum_{S'} e^{(\gamma_k^i(S_{k-1}, S_k) + \alpha_{k-1}(S_{k-1}))}) \quad (2.14)$$

$$\bar{\alpha}_k(S_k) = \text{Max}^*(\bar{\gamma}_k^i(S_{k-1}, S_k) + \bar{\alpha}_{k-1}(S_{k-1})) \quad (2.15)$$

$$\beta_{k-1}(S_{k-1}) = \ln \left(\sum_S e^{(\gamma_k^i(S_{k-1}, S_k) + \beta_k(S_k))} \right) \quad (2.16)$$

$$\bar{\beta}_{k-1}(S_{k-1}) = \text{Max}^*(\bar{\gamma}_k^i(S_{k-1}, S_k) + \bar{\beta}_k(S_k)) \quad (2.17)$$

Initial value for forwards and backwards probability in logarithmic domain are computed as:

$$\alpha_0(S) = \begin{cases} \ln(1) & S0 \\ \ln(0) & \text{other wise} \end{cases}, \quad \beta_N(S) = \left\{ \ln\left(\frac{1}{4}\right) \text{forevery } S \right.$$

The branch metric in logarithmic domain can be simplified to:

$$\gamma_k^i(S_{k-1}, S_k) = ((c_k^i * L^e I_k^j)/2) + \left[\frac{(y_k^1 * c_k^1) + (y_k^2 * c_k^2)}{\sigma^2} \right] \quad (2.18)$$

where i refer to binary number (0,1), j refer to number of decoder (0,1)

From (2.5) the Likelihood equation in logarithmic domain is

$$L(u_k) = \text{Max}_1^*(\bar{\gamma}_k^1(S_{k-1}, S_k) + \bar{\alpha}_{k-1}(S_{k-1}) + \bar{\beta}_k(S_k)) - \text{Max}_0^*(\bar{\gamma}_k^0(S_{k-1}, S_k) + \bar{\alpha}_{k-1}(S_{k-1}) + \bar{\beta}_k(S_k)) \quad (2.19)$$

The simulation results for PCCC code system are shown in Fig. 19 where Bit Error Rate (BER) and Frame Error Rate (FER) curves are plotted w.r.t. SNR.

2.6 Serial Concatenated Convolutional Code (SCCC)

2.6.1 SCCC encoder

A Serial Concatenated Convolutional Code (SCCC) is obtained using two convolutional encoders placed sequentially and using an interleaver in between. The SCCC encoder diagram is depicted in Fig. 10. The first encoder is desired to be a RSC code, while the second encoder does not need to be recursive systematic convolutional code. However, the first and second encoders are usually chosen from RSCs. For this reason we will use the same RSC with generation polynomial $(1, 5/7)_{\text{octal}}$ for both encoders. The code rate for the SCCC encoder is $R = R_F R_S$ where R_F & R_S are the code rates of the outer and inner convolutional encoders.

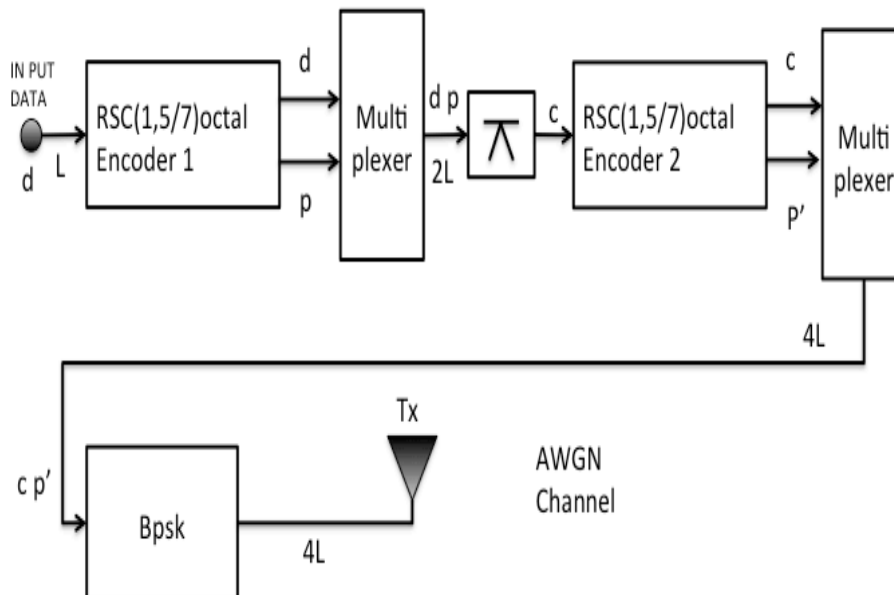

Figure 10 SCCC encoder diagram with RSC component codes and S-R Interleaver

2.6.2 SCCC decoder

Figure 11 shows the Serial Concatenated Convolutional Code (SCCC) decoder diagram. The component SISO decoders exchange soft information in every iteration. After a sufficient number of iterations which is usually chosen as 8, decision is made by decoder-1.

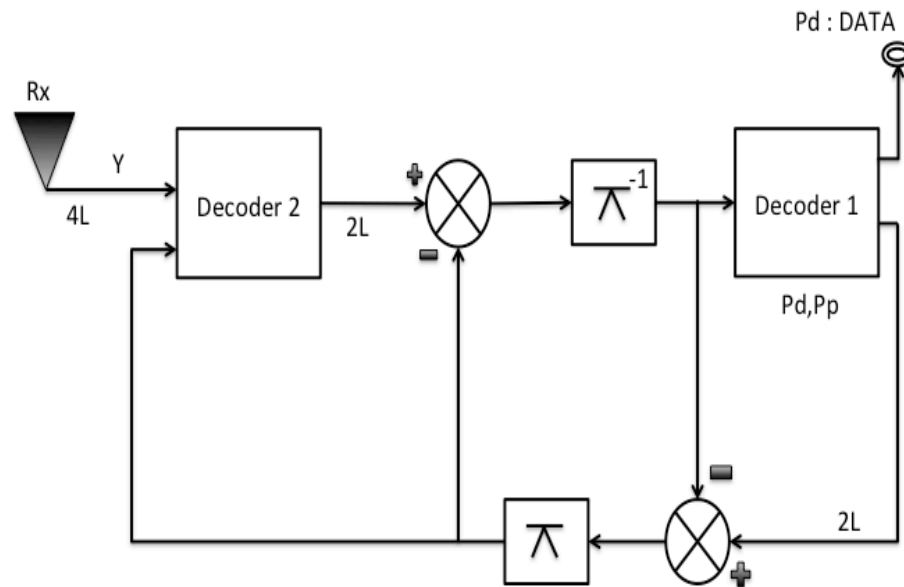

Figure 11 SCCC decoder diagram

The aim of iterative decoder is to iteratively estimate of the a-posteriori probabilities (APPs) $P_r(u_k | y)$ where ever u_k is the k^{th} information bit, $k=1,2,\dots,N$, and y is the noisy received signal at the destination, $y = c + n$. In this equation the codeword sequence consist of BPSK modulated symbols, i.e., the set $[-1, +1]$, n is the noise AWGN samples. Likelihood ratios for the bits u_k are computed as:

$$L(u_k) = \frac{p(u_k=1|y_k)}{p(u_k=0|y_k)} \quad (2.20)$$

And the decision is made using:

$$u_k = \begin{cases} 0 & L(u_k) < 1 \\ 1 & L(u_k) > 1 \end{cases}$$

The simulation result of SCCC code system is shown in Fig. 19 where Bit Error Rate (BER) and Frame Error Rate (FER) performance curves are drawn. The information sequence length L is equal to 1024 bits and the frame length is equal to 4096 bits. The interleaver, which is used in the simulation called S-Random Interleaver and the number of iterative in the decoding part, is equal to 8.

2.7 Convolutional Product Codes (CPC)

The encoder and decoder block diagrams of the Convolutional Product Codes (CPC) are shown in Fig. 12. The Convolutional Product Code (CPC) is derived from Serial Concatenated Convolutional Code (SCCC). The main idea of CPC is to divide the information frame into sub-frames and share the decoding load to more than one processor at the receiver side. In the encoder part, the information frame d_i is divided into sub frames (1,2,3... m) and each sub frame is encoded separately resulting in the codeword c_i . After that, parallel to serial conversion operation is performed resulting in the sequence X_i . The sequence X_i is interleaved by S-Random interleaver producing m_i . S-Random interleaver shows better performance for the system than many other interleavers. The frame m_i is converted to the same number of sub frames m again and each sub frame also is encoded separately producing n_i . After that, n_i is converted into one frame, which is Y_i . The sequence Y_i is modulated and transmitted through the channel to the destination.

For the decoding operation Max-Log-MAP Algorithm is used in CPC system. After the frame Y_i is received by the decoder part, the frame Y_i is divided into sub frames and each sub frame is decoded by Max-Log-MAP Algorithm separately. The produced bit probabilities are de-multiplexed and passed through an inverse S-Random interleaver. Next, inverse interlaved probability vector is feeded to inner decoder cluster for a-priori information after serial to parallel conversion operation. These operations are repeated for a sufficiently number of times and then the decision on the probabilities is made.

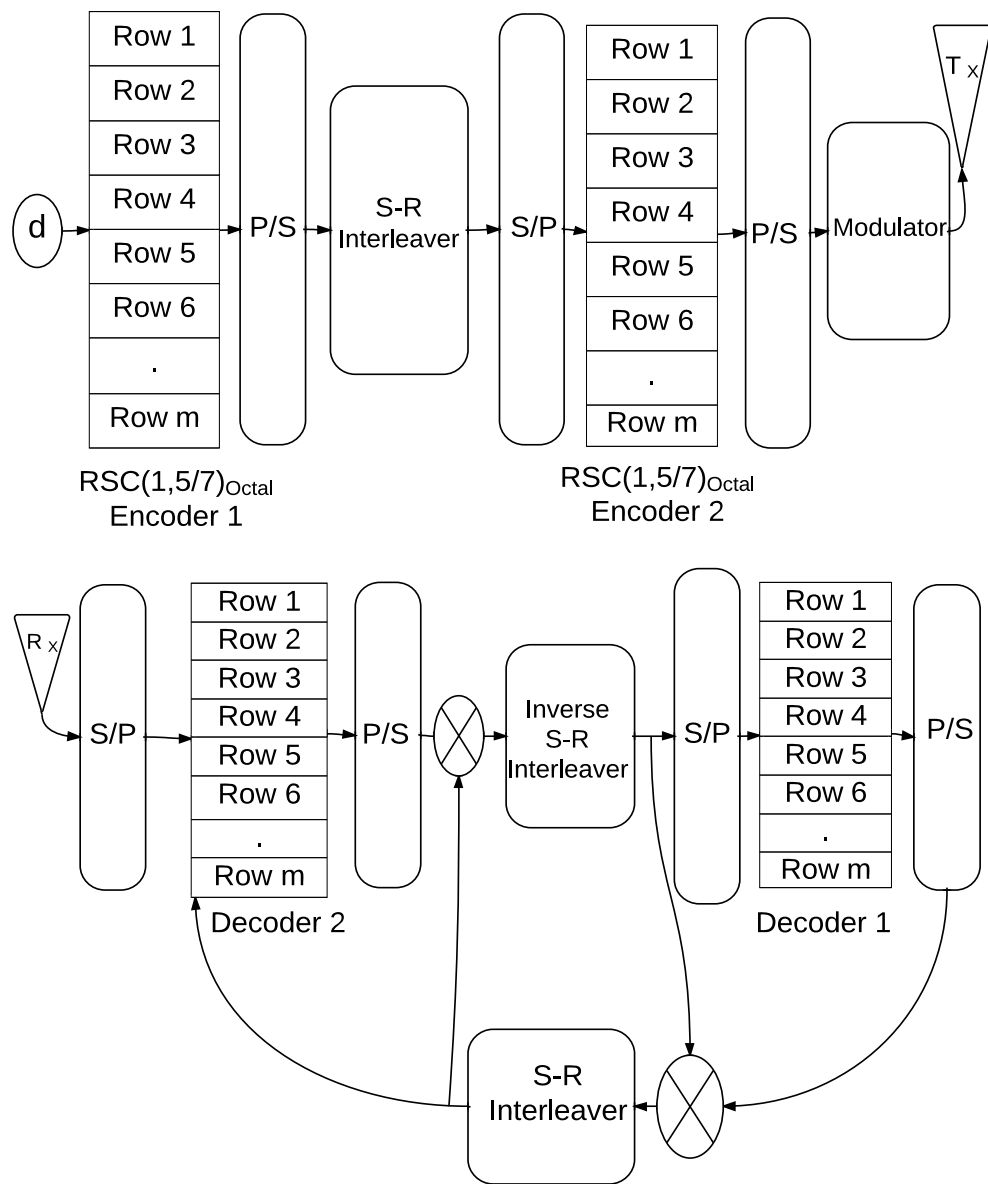

Figure 12 CPC encoder and decoder diagram

The simulation results for CPC code is shown in Fig. 20 for which the number of rows equal to $m=4$. And in Fig. 21 simulation results for the number of rows $m=8$ are plotted.

CHAPTER 3

The USE OF CPCs IN COOPERATIVE COMMUNICATION SYSTEMS

3.1 The Cooperation Channel Code Form

The cooperative communication system is shown in Fig. 13, where source S sends frames to the destination D with the cooperation of M Relay nodes, R_k , $k = 1, 2, \dots, M$. We assume that the number of CPC codes is equal to m and denoted by C_i . It is assumed that the source send information vectors consisting of bits denoted by a_i . In this thesis, two concatenated codes which are SCCC and CPC are used in cooperative communication systems. The vector C_i is sent to destination D and to all relay nodes R_k . After the transmission of signals to the destination D and the entire relay nodes R_k , noisy signals are available at the destination indicated by the vectors Y_i . The vectors Y_i are received by relay nodes. We propose methods for cooperative communication systems employing CPCs to increase the performance and/or decrease the latency. One of these proposals is the classical one, which is explained as follows. The Relay (node) R_k receives and decodes the vector Y_i and re-encodes the data and sends it to the destination D as show in Fig. 13. All the packets received from relays and source are combined by the destination D. All the packets combined and are decoded at destination D.

There are a few methods to combine the packets. In this thesis, Maximum Raito Combining (MRC) Method and Individual Decoding Method (IDM) are used.

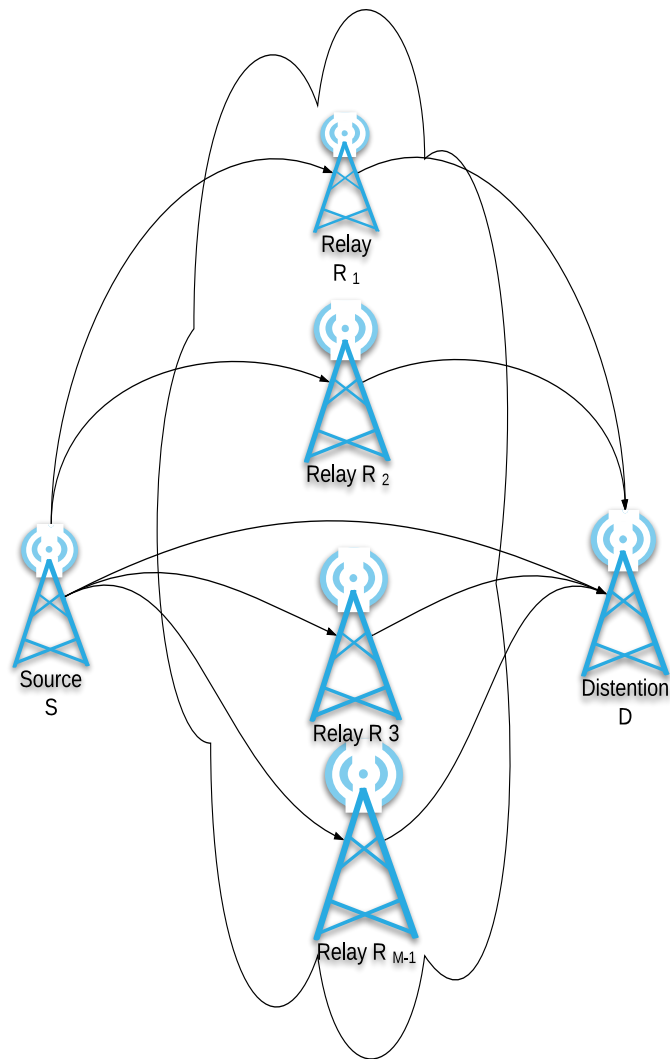

Figure 13 Base structure of the cooperation channel code

3.1.1 Maximal ratio combining (MRC) method

Maximal-ratio combining is a method in which the signals received from every different channels are combined in a way regarding their SNRs. It is also named as ratio-squared combining and pre-detection combining. In maximal ratio combining (MRC), the signals from the entire MR sections are measured according to their specific SNRs and then combined. Maximum Ratio Combining (MRC) method is widely used in MIMO systems. It can also be used in cooperative communication systems where destination receives all the signals coming from the relays and source and combines them.

3.1.2 Individual decoding method (IDM)

This method shows a significant improvement and better performance at the same time. In addition, this method takes more time to decode the signals increasing the latency at the destination D. The main idea of this method is to process each signal received from the relay nodes R_k and the source S separately. When decoding is complete, the data probabilities (a-priori probabilities) are stored for all bits. Moreover, it is possible to give each signal a percentage, which means to give some signals reliability more than other. For the cooperative coded system with two relay nodes R_2 , there are three signals available at the receiver side (two from relay nodes R_2 and one from the source S). More attention can be paid to the signal coming from the source S to the destination D by employing a scaling factor used to scale every a-priori probability for the bits transmitted from the source. For instance, during the probability combination method the probabilities obtained from S-D path can be scaled by 50 per cent and the other two about 50 per cent, each one has 25 per cent. In this case, the a-priori probabilities for S-D path are multiplied by 0.5 and for the other two probabilities (R-D paths) each one are multiplied by 0.25. Eventually, all the data probabilities are added together for every bit. During the separately decoding process, there are two strategies at the destination D. First is the sharing the a-priori probabilities between the signals. For example, the first signal arrival is the signal coming from the source S to the destination D directly (S-D path). This signal is decoded the a-priori probabilities of this signal is fed as a-posteriori probabilities to the next signal arrival to the destination D. Then the a-priori probability for the second arrival signal is fed as a-posteriori probabilities for the third signal and this procedure goes on until the last received signal. This means, the number of processing depends on the number of relay nodes. This strategy is called “*Sharing the A-priori*”. In the second approach, decoding of each signal is totally separated from each other without sharing the a-priori between signals. So, this strategy is called “*Without Sharing the A-priori*”.

3.2 SCCC in Cooperative Communication

3.2.1 Full encoding in relays (Classical Method)

This is the classical design in the relays as is shown in Fig. 14. The received signals at the relays are decoded and re-encoded. The decoders employ Max-Log-Map Algorithm for the decoding operation. The decoding operation is illustrated in Fig. 14. Before the decoder-1 receives the information, the information is passed through an inverse interleaver. Then the information is fed the decoder 1. The decoder 1 employs Max-Log-Map Algorithm and feeds the data and the parity bits probabilities to the decoder-2 through the interleaver. This operation is done several times (iterations). When the iterations are done, the hard decision is made on the data bits probabilities. After making the hard decision on data bits probabilities, the bits are transferred to the encoder part and re-encoded. The encoded bits are modulated by Binary Phase Shift Key (B-PSK) and transmitted to the destination D.

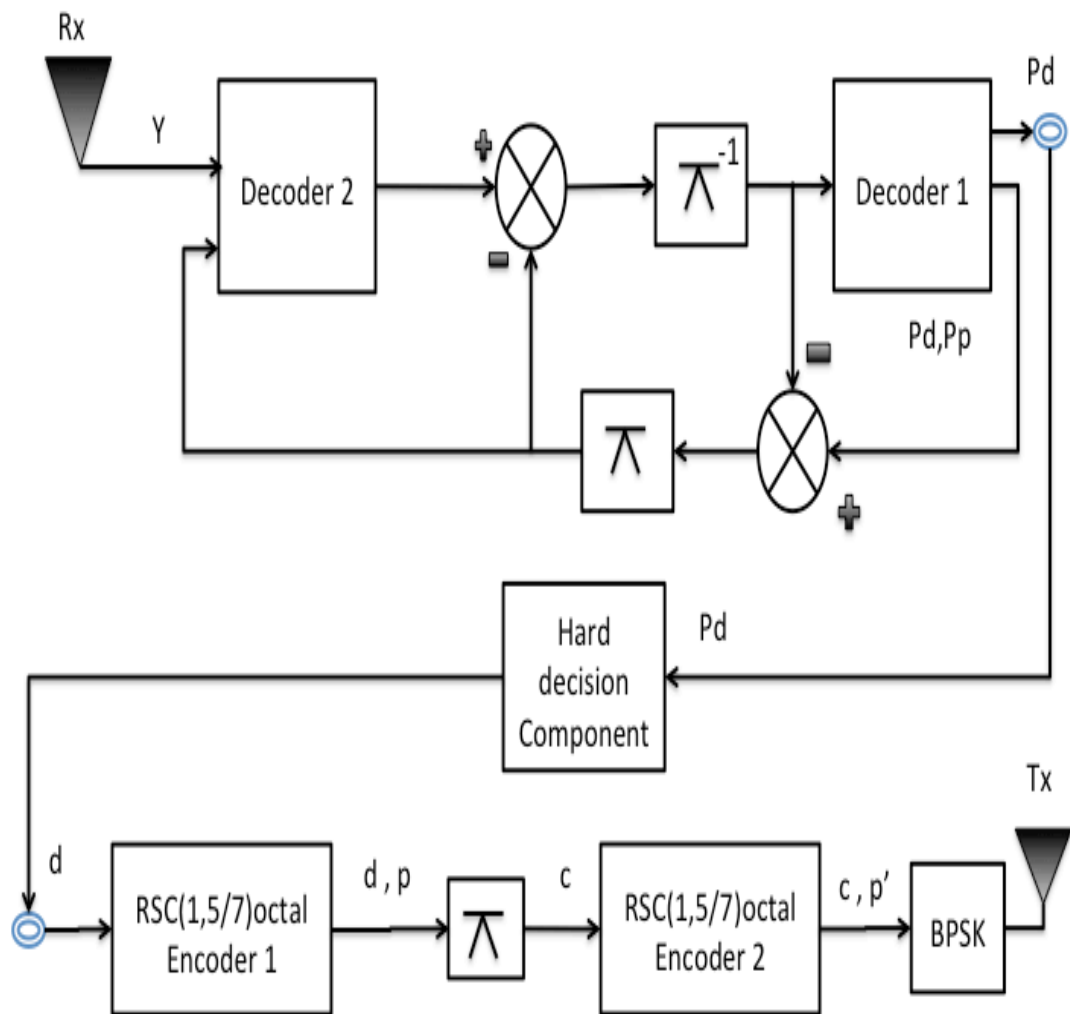

Figure 14 Decoding and encoding operation at the relays

3.2.2 Soft Decoding with Half Hard Decision in Relays

In this design (HHDE), the hardware complexity in the relays is less as shown in Fig. 15. This means, the latency is less and at the same time the system performance is better as shown via computer simulations in Fig. 23. The relay receives the frame, which is sent from the source S and passes to the decoder part. The decoder-2 employs Max-Log-Map Algorithm and gives the information to the decoder-1 as a-posteriori probabilities after passing through an interleaver. The decoder-1 uses Max-Log-Map Algorithm for decoding and the obtained data bits probabilities and the parity bits probabilities are given to the decoder-2 after passing through an interleaver. These operations are repeated several times

When the iterations are complete, the hard decision is made on the data bits probabilities and the parity bits probabilities. After the hard decision is made on the data bits probabilities and the parity bits probabilities, these bits are transferred directly to the interleaver and then the relay node encodes these bits by the same component code (for example we use RSC $(1, 5/7)_{\text{octal}}$ Encoder) and the encoded bits are modulated by Binary Phase Shift Key (B-PSK) modulator, and then are sent to the destination D. The difference between this method and the one in the previous sections is that after decision is made encoding is only performed once.

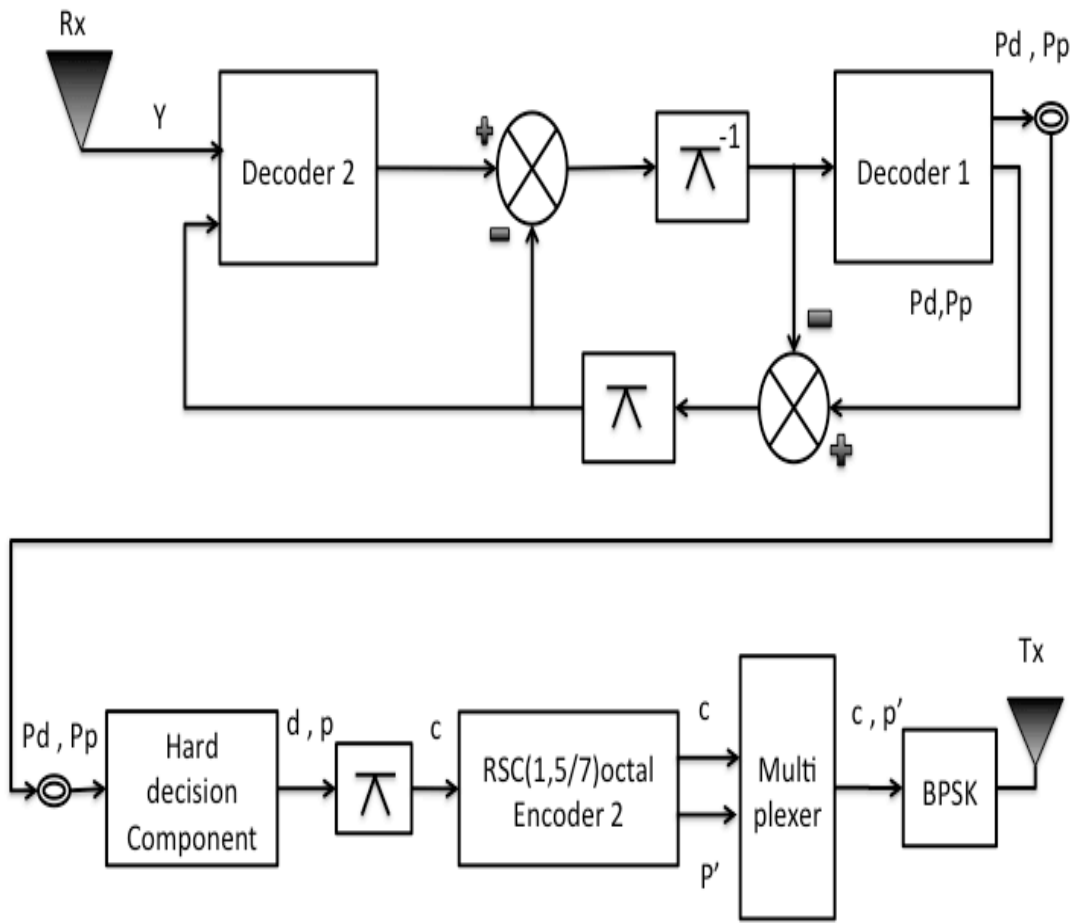

Figure 15 Relay structure of *Soft Decoding with Half Hard Decision in Relays*

3.2.3 Soft Decoding with Full Hard Decision in Relays

The communication system for this approach is depicted in Fig. 16. The performance of this approach is better than the classical one (First strategy or the Full Encoder in Relays), but less than the second strategy. This means the performance level of this strategy is between the *Classical Method* and the second strategy (HHDE). This system is simulated in computer for three relays and results are shown in Fig. 24. The situations which contains of four relays is simulated and present the result in Fig. 25. The relay receives the packets sent from the source S and passes them to the decoder part. The Max-Log-Map Algorithm is employed at the decoder and the decoded information form decoder-2 is given to the decoder-1 as a-posteriori probabilities. Before the decoder-1 received the information, the data is passed through an inverse interleaver. Then the information is fed the decoder-1. The decoder-1 also employs Max-Log-Map Algorithm and generated data bits probabilities and the parity bits probabilities are passed to the decoder-2 through an interleaver. This operation is repeated for a sufficient number of iterations. When the iterations are done, the hard decision is made on the data and parity bits probabilities, which are processed by the decoder-2. After the hard decision which is made on the data bits probabilities and the parity bits probabilities, the decoded bits are transferred directly to the Binary Phase Shift Key (B-PSK) modulator without encoding operation and then are resent to the destination D. The conclusion for this strategy is that the computational complexity is less at the destination since re-encoding operation is not performed. This means, there is less processing time (latency) at the destination nodes.

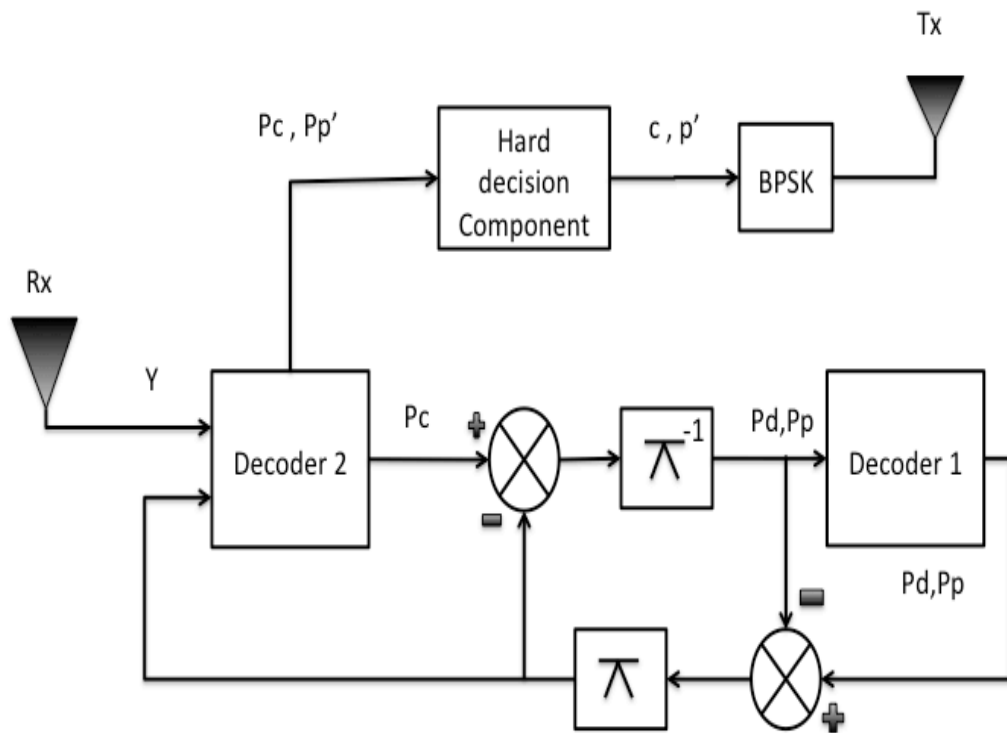

Figure 16 Relay structure of *Soft Decoding with Full Hard Decision in Relays*

3.3 Using CPCs in Cooperative Communication

This idea has the lowest latency. At the same time, it is more complex than others (Hardware Complexity). The main idea of the CPC strategy is to divide the sequence into sub-frames and all the frames are processed (Decoding and/or Encoding) at the same time. This means the latency is divided by the number of sub-frames, as it is shown in Fig. 12. Figure 17 shows the use of CPC strategy in the cooperative communication system. The relay receives the data packets and passes it to the decoder part. The decoders perform the decoding processing, as it was explained in Chapter-2 (2.7 Convolutional Product Codes (CPC)), and use the same number of rows, as used in the source S. After all the iterations are finished, the hard decision is made on the data bits. Then, the bits are passed to the encoder part for re-encoding,

as it was explained in CPC method (Chapter Two), with the same number of rows that are used in the source S. After re-encoding operations, the information frames are sent to BPSK modulator and transmitted to the destination D. This idea is being simulated in computer with different cases where different numbers of relay nodes are considered. Figure 29 is shown the CPCs in the cooperation channel codes system performance and the comparison between the CPCs and SCCCs (Classical strategy) in cooperation channel codes system.

Table 1 is being shown the advantages and the disadvantages for every strategy, and the comparison between classical strategy, CPC in the cooperation channel code system, FHDE strategy and HHDE strategy.

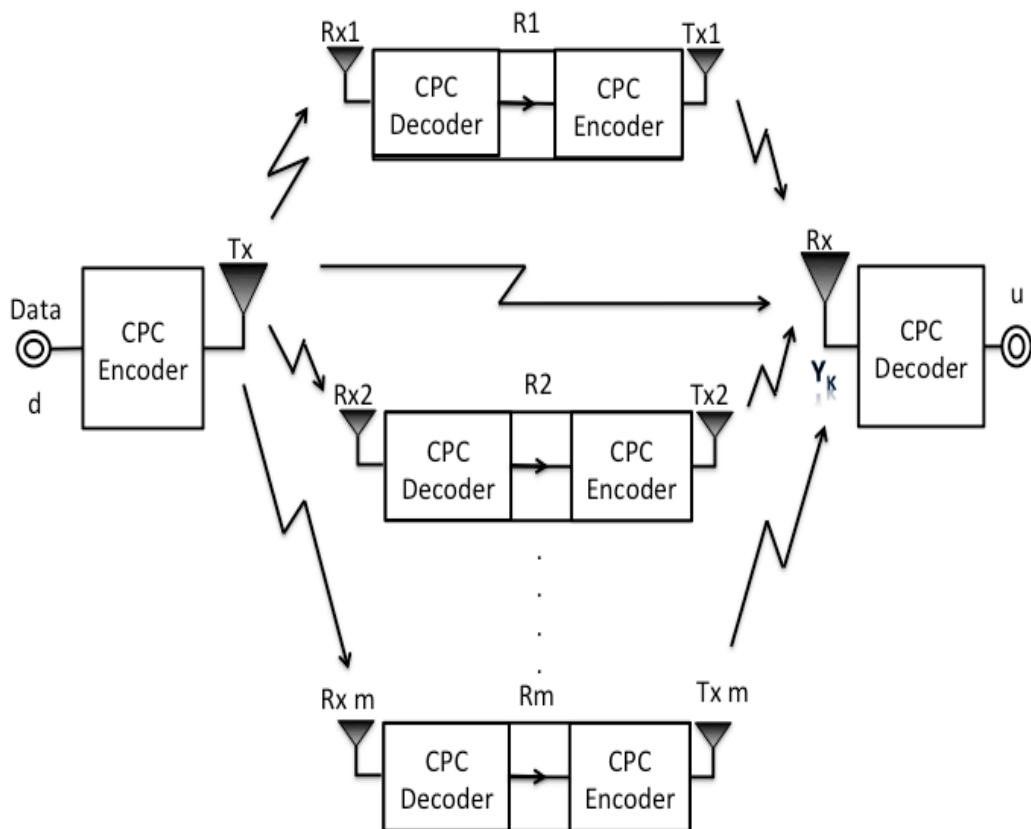

Figure 17 CPC in cooperative communication

Table 1 Comparison Between *Classical Method, Half Hard Decision, Full Hard Decision Encoding* and CPC in Cooperative Communication

Systems Features Ideas	Performance	Latency	Complexity
Full Encoder	Good	Normal	Normal
HHDE	Very good	Less than SCCC	Less than SCCC
FHDE	Better than SCCC and less than Half hard decision	Less than the previous two	Less than the previous two
CPC	Almost the same with SCCC	Lower than all the previous ideas	Higher than SCCC

CHAPTER 4

SIMULATION RESULTS

4.1 General Information About the Results

For our simulations the information frame length is chosen as 1024 bits. We used recursive systematic convolutional code (RSC) $(1, 5/7)_{\text{oct}}$ as component codes for all the concatenated structures. The encoder circuit of the RSC used in our studies is shown in Fig. 6. S-Random interleaver is used in all the systems with $S=20$. Log-MAP Algorithm method is used to decode the received streams at the receiver part (at the relay nodes and at the destination D). The cooperating nodes (relays) lie between the source S and the destination D. All the channels that are used are half-duplex. The number of iterations for the decoding process is chosen as 8. B-PSK modulation is used for all the simulations.

All the results that are obtained via computer simulation softwares written in C++ language.

4.2 PCCC Simulation Results

PCCC (Turbo) code of rate $R = 1/3$ with S-Random interleaver is simulated with frame length equal to 1024 bits. The encoded frame is transmitted through an Additive White Gaussian Noise (AWGN) channel. Bit Error Rate (BER) and Frame Error Rate (FER) performance curves are depicted in Fig. 18 with and without using trellis termination. From the Fig. 18, it is obvious that the system with trellis termination has better performance.

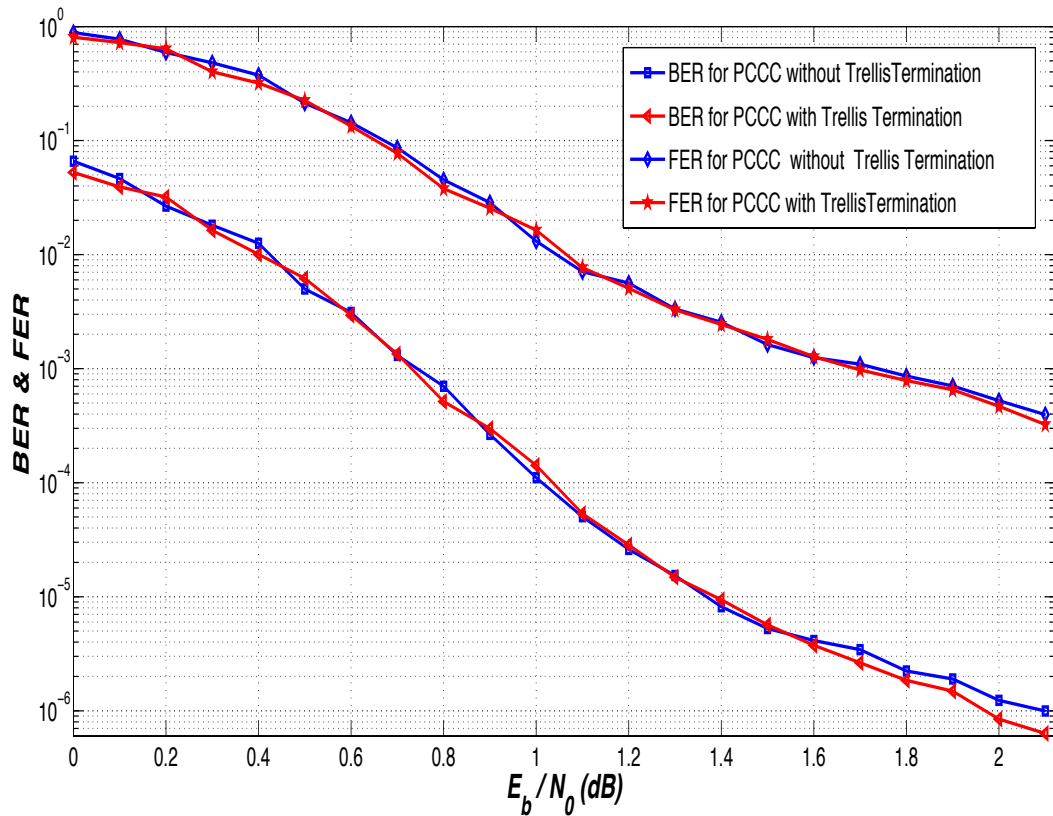

Figure 18 PCCC Bit Error Rate (BER) and Frame Error Rate (FER) simulation results

4.3 SCCC Simulation Results

Figure 19 shows the computer simulation results for serial concatenated convolutional code (SCCC) system employing iterative decoding algorithm. Simulation results for both Bit Error Rate (BER) and codeword or Frame Error Rate (FER) are presented. The code rate is $R=1/4$, S-Random Interleaver with length 2048 bits is used. The data frames are transmitted over an Additive White Gaussian Noise (AWGN) channel.

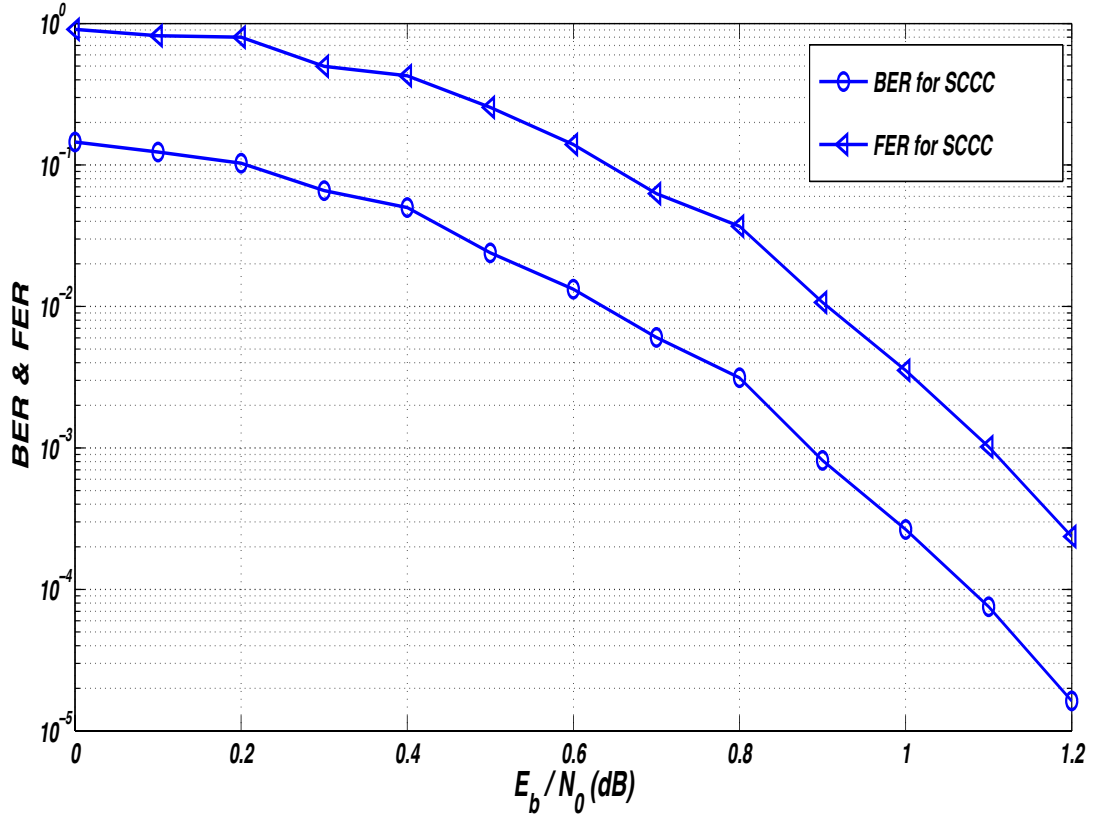

Figure 19 SCCC Bit Error Rate (BER) and Frame Error Rate (FER) simulation results

4.4 CPC Simulation Results

Figure 20 and 21 present the computer simulation results for CPC systems which are processed using the iterative decoding algorithms. Simulation results for both Bit Error Rate (BER) and codeword or Frame Error Rate (FER) are presented. The code rate is $R=1/4$. The number of CPC rows number is equal to $m=4$, which reduces the decoding latency by a factor of $1/4$ when compared to SCCC system where parallel processing is not employed. In Figure 22 simulation result of CPC for $m=8$ are presented. In this case, the decoding latency is decreased by a factor of $1/8$ when compared to SCCC (i.e., if decoding latency for (SCCC equals to t , the CPC system time with $m=8$ will have $t/8$ as decoding latency). S-Random interleaver whose length is 2048 is used in the CPC system. The frames are transmitted over an Additive White Gaussian Noise (AWGN) channel with peer-to-peer strategy.

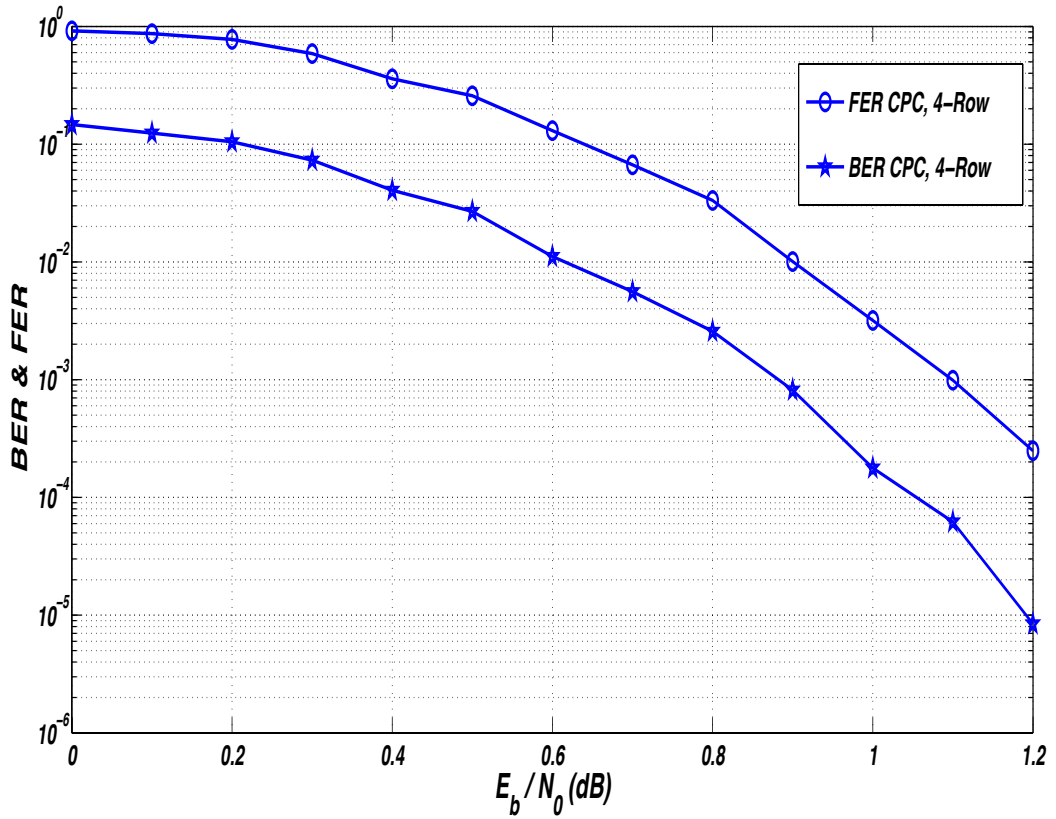

Figure 20 CPC Bit Error Rate (BER) and Frame Error Rate (FER) simulation results with m=4 rows

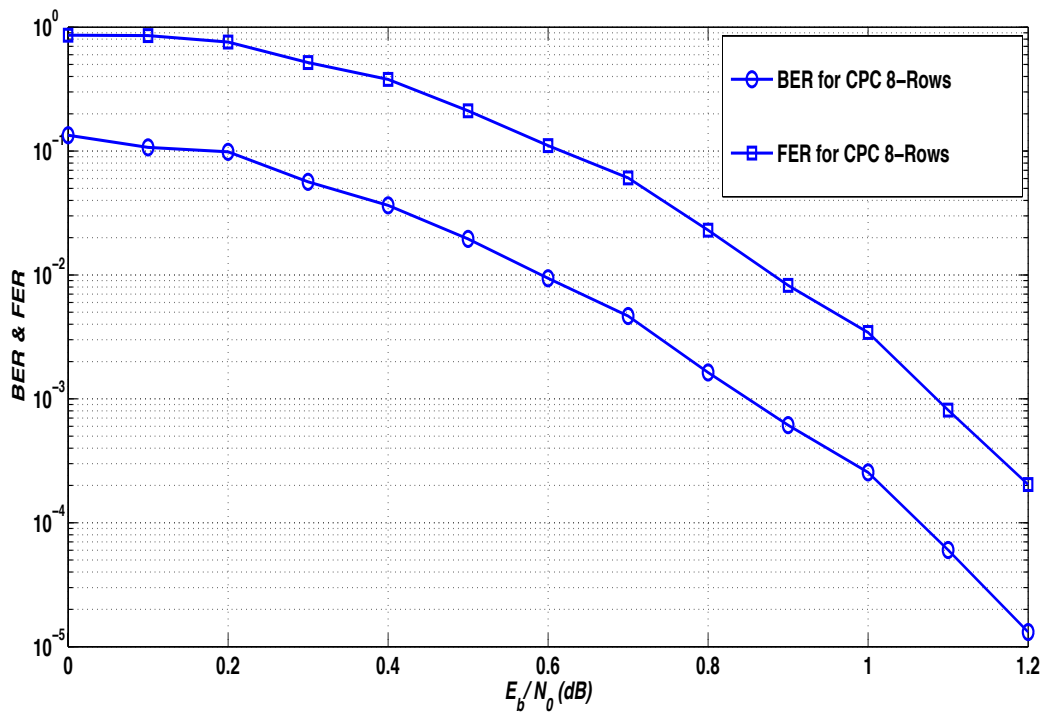

Figure 21 CPC Bit Error Rate (BER) and Frame Error Rate (FER) simulation results with m=8 rows

4.5 SCCC in Cooperative Communication

4.5.1 Full encoding case

Figure 22 shows the BER performances for the cooperative communication using serial concatenated convolution codes (SCCCs) with different cases, each case has different number of relay nodes. The cooperative cases are compared to the case without cooperation (direct transmission). As it is seen from the Fig. 22 performance improves as the number of relay nodes is increased. In these simulations, we used the classical method (Full Encoder in the Relays) in the relay nodes. In the destination D, we used the Maximum Ratio Combining (MRC) method to combine the signals, which are transmitted from the relay nodes R and from the source S and then the combination result is passed to the decoder. It is seen from the simulation results that the BER performance of the cooperative systems become better as the number of relay nodes are increased. The noisy channels over which data frames are transmitted are the Additive White Gaussian Noise (AWGN) channels.

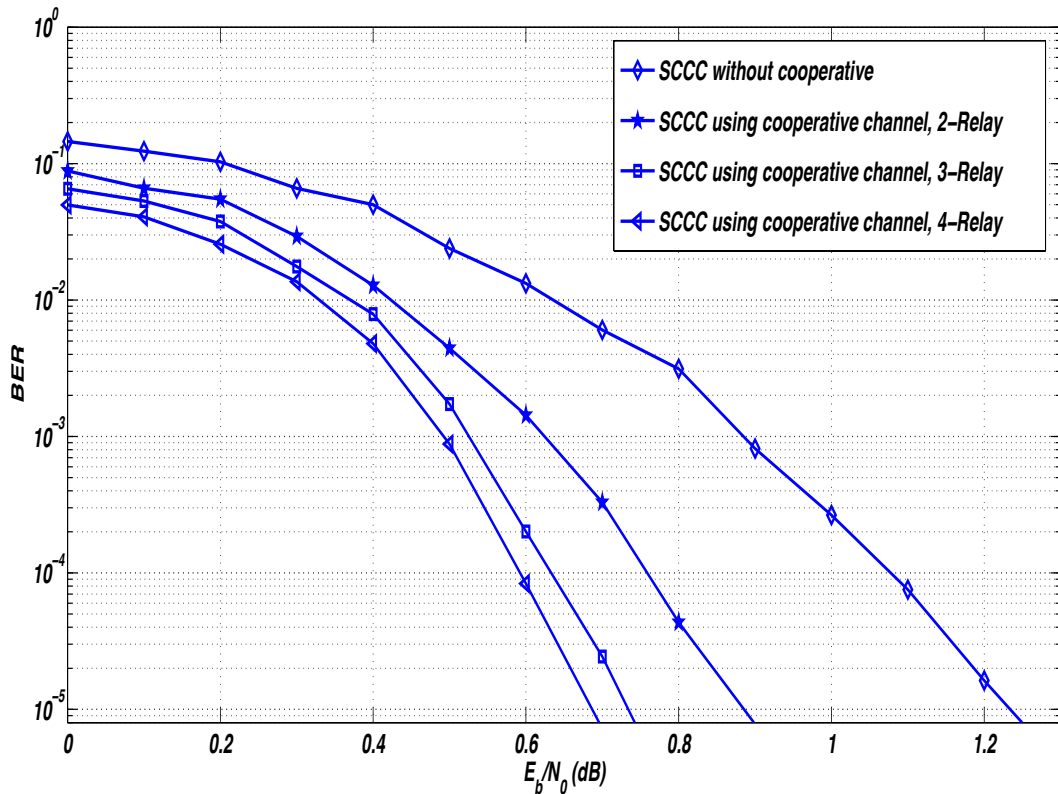

Figure 22 SCCC BER performance for relay communication systems, Full Encoding Decoding operation are performed in relays.

4.5.2 Simulations for *Soft Decoding with Half Hard Decision in Relays*

In Figure 23 the performance comparison of Soft Decoding with Half Hard Decision Encoding in Relays (HHDE) and the Classical Method (Full Encoder in the Relays) are depicted. In this Figure the BER performances of the cooperative communication systems with different cases, each case has specific number of relay nodes and non-cooperation network systems (the direct transmission without cooperation notes) are displayed. It is seen that the BER of the cooperation network for the “*Soft Decoding with Half Hard Decision Encoding in Relays*” (HHDE) is better than the direct transmission system and the classical method (Full Encoder in the Relays). In addition, our cooperation scheme 2 (HHDE) has less hardware complexity by ignoring the first encoder and passing the parity bits probabilities and the data bits probabilities from the decoder-1 to the inverse interleaver through the hard decision component. The data frames are transmitted over Additive White Gaussian Noise (AWGN) channels. And the method, which is used to collect the signals at the destination D, is Maximum Ratio Combine (MRC) method.

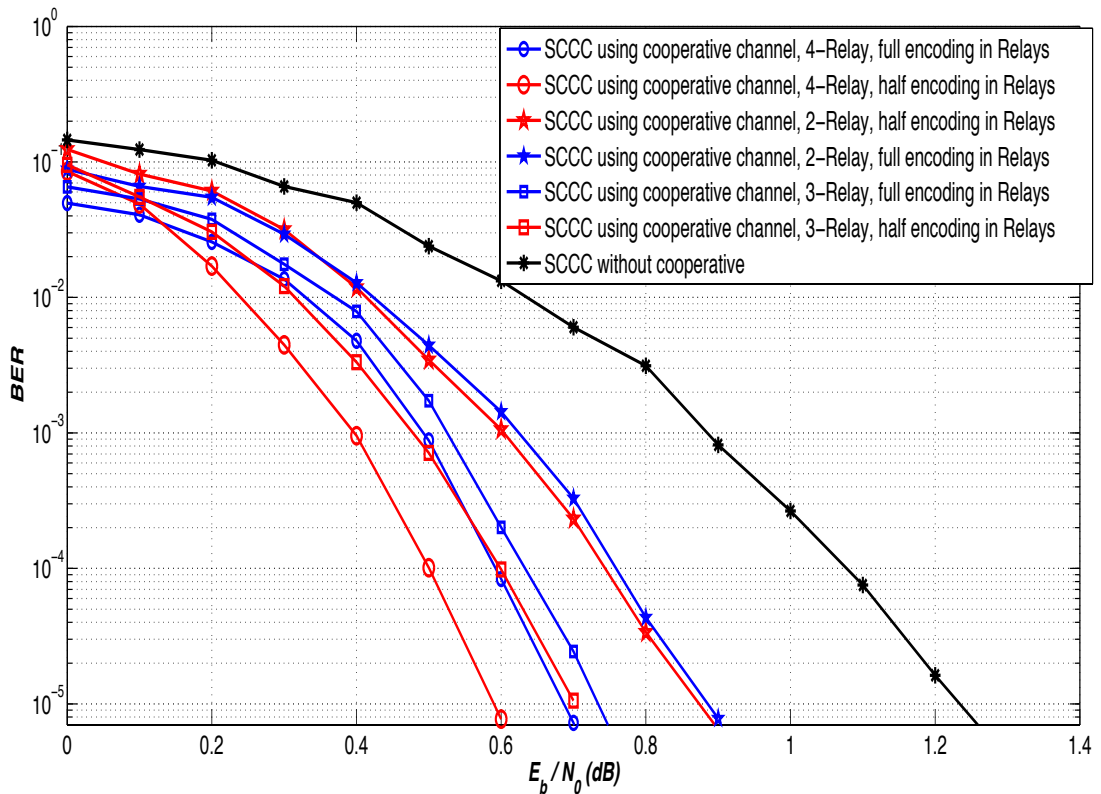

Figure 23 Comparison between *Soft Decoding with Half Hard Decision in Relays* and *Classical Method* using MRC, Bit Error Rate (BER) simulation results are depicted.

4.5.3 Without encoding in the relays

Figure 24 and 25 depict the BER performances of the cooperative communication systems over Additive White Gaussian Noise (AWGN) channels. In these two figures, we compare five systems. Serial concatenated convolutional code (SCCC) is used in all the five systems. In Figure 24, the number of the relay nodes is equal to $A_{rk}=3$ for all the five cooperation networks. In Figure 25, the number of the relay nodes is equal to $R_k=4$ for all the five cooperative systems. In the following lines we explain every curve in the graphs, one by one, starting from the less performance results to the highest performance results.

First curve (full encoding in relays) is the cooperative communication system where the *Classical Method* strategy is used for it as it is explained in 3.2.1 and simulated in 4.5.1 (Full Encoding Case) with the results in Fig. 22. We use Maximum Ratio Combine (MRC) to combine the signals at the destination D.

Second curve (Soft Decoding with Full Hard Decision Encoding, MRC) is the cooperative communication system where the FHDE strategy is used for it as it is explained in 3.2.3. It shows better than the *Classical Method* and shows worse performance than the HHDE. Also Maximum Ratio Combine (MRC) is used.

Third curve (Soft Decoding with Half Hard Decision Encoding) is the cooperative communication system where the HHDE is used. This cooperative communication system is explained in 3.2.2 and simulated in 4.5.2, and it shows the results in Fig. 23. We also used Maximum Ratio Combining (MRC) to collect the signals at the destination D.

Fourth curve (full encoding in relays, without sharing the a-priori at the destination) is the cooperative communication system where the *Classical Method* is used for. And use IDM method to collect the signals at the destination D. To be more precise, there are two methods for IDM method; one of these methods is *Without Sharing the A-priori* and this method is used in cooperative communication system.

In the fifth curve (full encoding in relays, sharing the a-priori at destination), the *Classical Method* is used at the relay nodes, as it is explained previously. And IDM method is used to combine the signals at the destination D. To be more specific, *Sharing the A-priori* method which is one of IDM's method is used in this curve.

The first curve, the second curve and the third curve are compared to each other in Table 1 (as we mentioned before in Chapter 3).

The cooperative systems in the fourth and fifth curve are designed to increase the system performance. However, the latency is increased at the destination D; i.e. the hardware in the system is more complex by adding memory device to store the a-priori probabilities for each receiving signal. Another reason for increasing the latency is that each receiving signal is decoded separately, which increases latency.

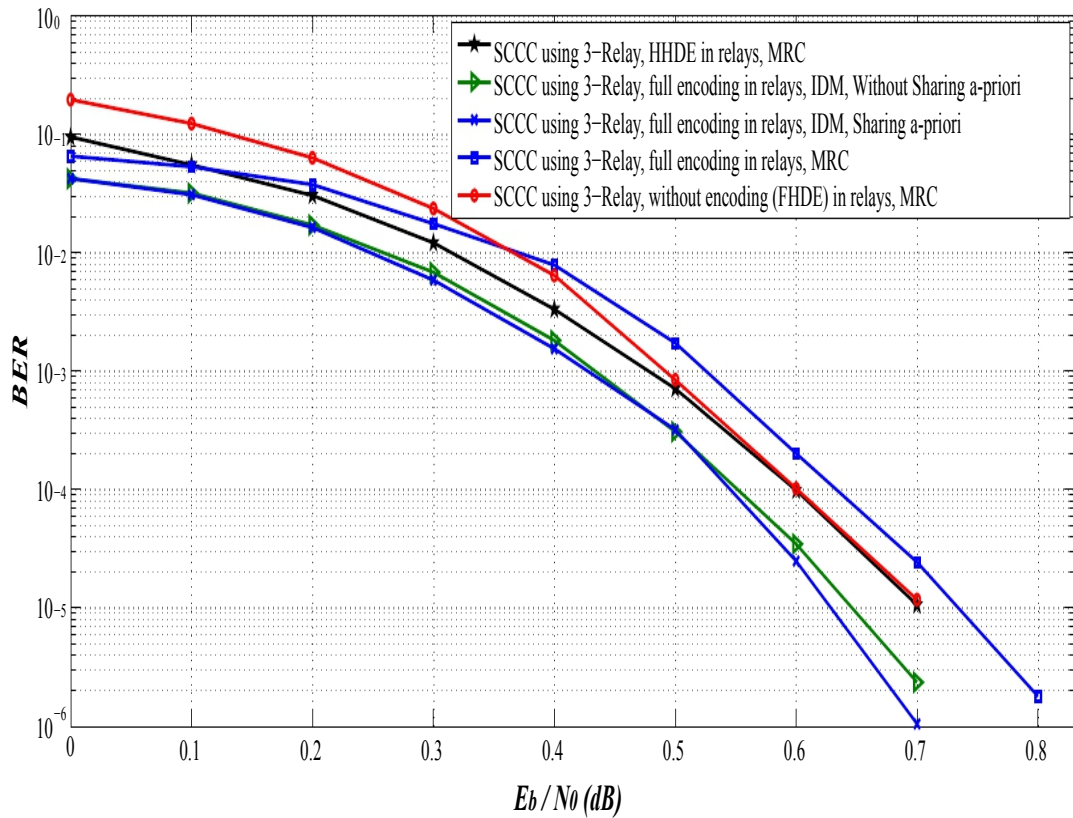

Figure 24 SCCC in cooperation channel code with 3-Relay comparison between MRC and IDM methods, Bit Error Rate (BER) simulation results are depicted.

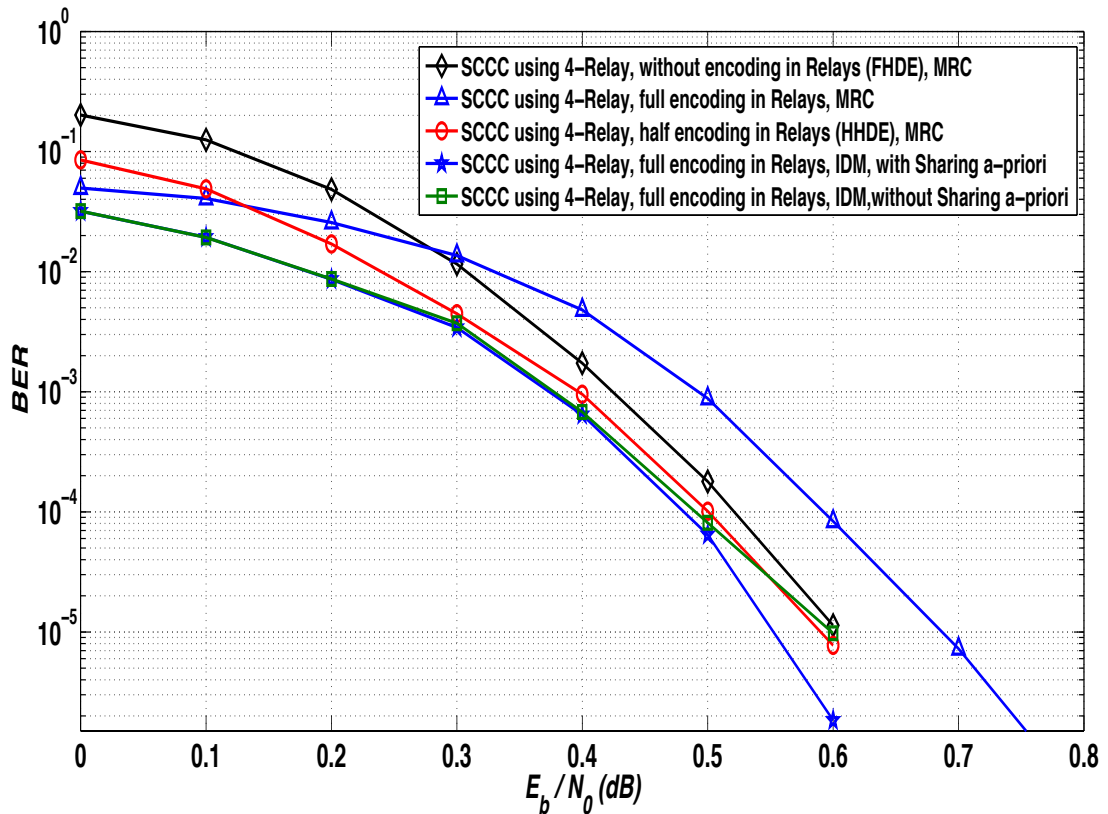

Figure 25 SCCC in cooperation channel code with 4-Relays Using MRC and IDM methods, Bit Error Rate (BER) simulation results are displayed.

4.6 Using Individual Decoding Method (IDM) for Cooperative Communication Systems Employing SCCCs

4.6.1 Decoding with and without sharing the a-priori information

Figure 26 shows Bit Error Rate (BER) performance comparison several cases, all these curves are for SCCC in cooperative communication systems for Additive White Gaussian Noise (AWGN) channels, and each curve corresponds to a different number of Relays. In these simulations, Individual Decoding Method (IDM) is used to combine the signals at the destination. In Figure 26, we compare *Sharing the A-priori* method to *Non-Sharing The A-priori* method. Different cases are simulated and; each case has different number of relay nodes comparing to the case without cooperation (direct transmission). *Sharing the A-priori* method shows a significant improvement and better performance in BER considering the *Non-Sharing the A-priori* method. In these simulations, we use the classical method (Full Encoder in the Relays) in the relay nodes.

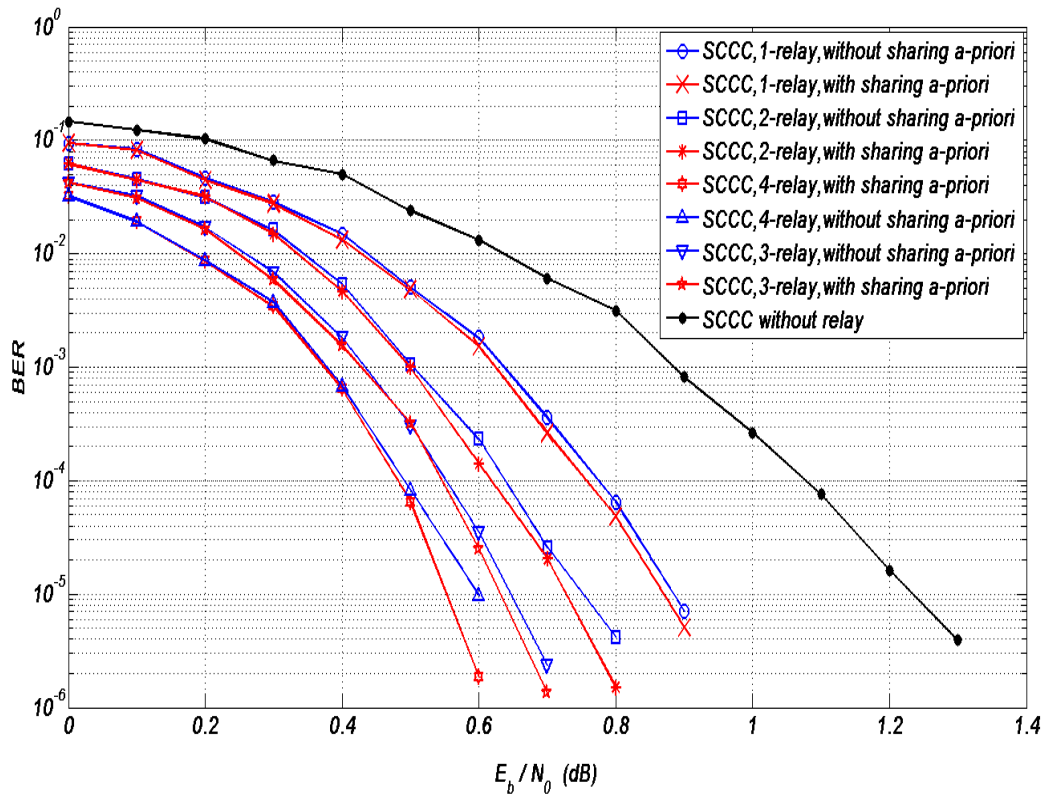

Figure 26 SCCC in cooperation channel code using IDM method, *Soft Decoding with Full Encoding in Relays*, With and Without Sharing A-priori, Bit Error Rate (BER) simulation results

4.6.2 Sharing the A-priori between the signals over fading channels

Figure 27 shows comparison of several cases of Bit Error Rate (BER) performances, as well as Fig. 28 shows Frame Error Rate (FER) performances for SCCC in cooperative communication systems over fading channels, each curve has different number of Relays. In these simulations, perfect channel estimation is assumed. Individual Decoding Method (IDM) is used to combine the signals at the destination. And we also use *Sharing The A-priori* method between the signals. Different cases are simulated; each case has different number of relay nodes comparing to the case without cooperation (direct transmission). It shows a significant improvement with increasing the relay nodes. In these simulations, we use the *Classical Method* (Full Encoder in the Relays) in the relay nodes. These previous methods, which are mentioned, gave powerful system performances in the fading field.

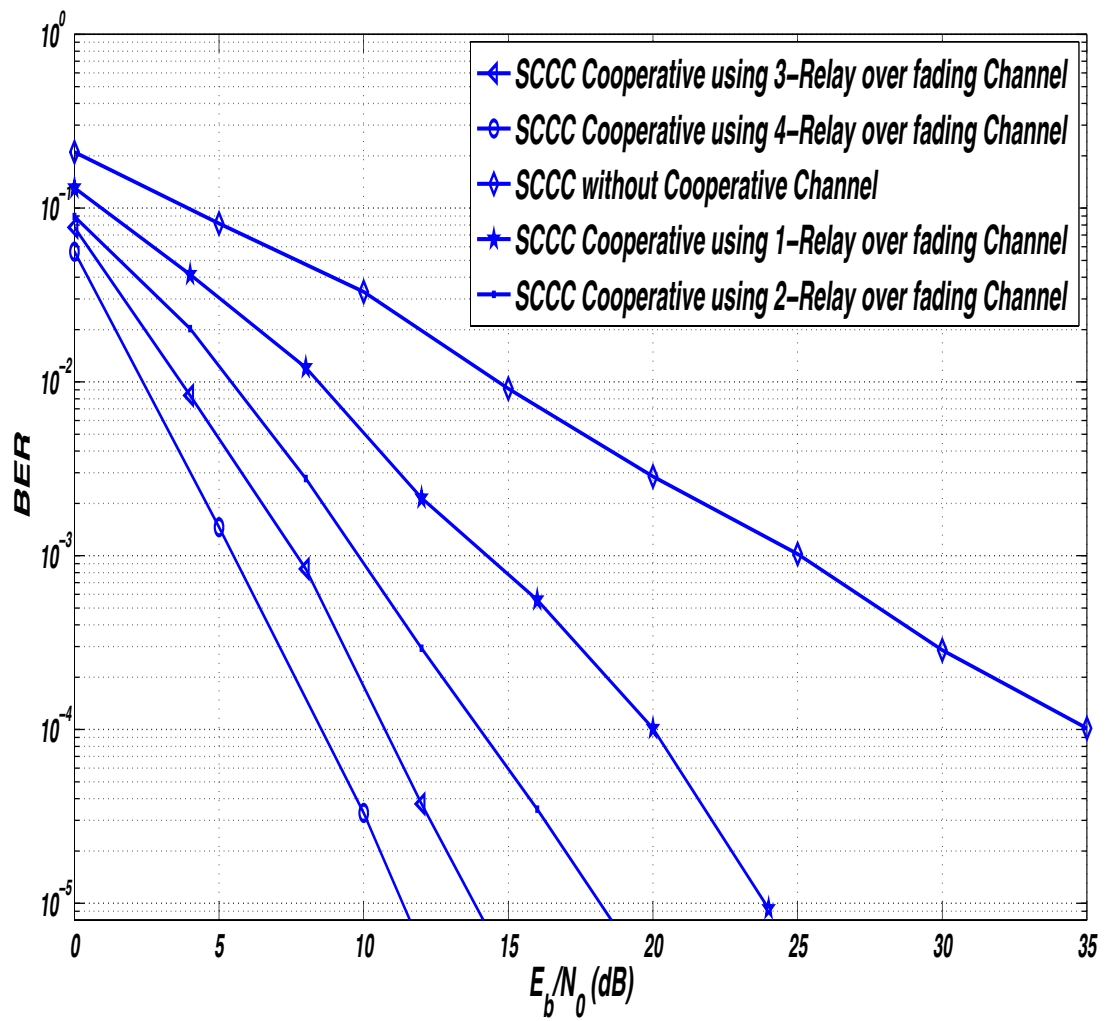

Figure 27 SCCC in cooperation channel code using IDM method, *Soft Decoding with Full Encoding in Relays*, over fading channels, Bit Error Rate (BER) simulation results

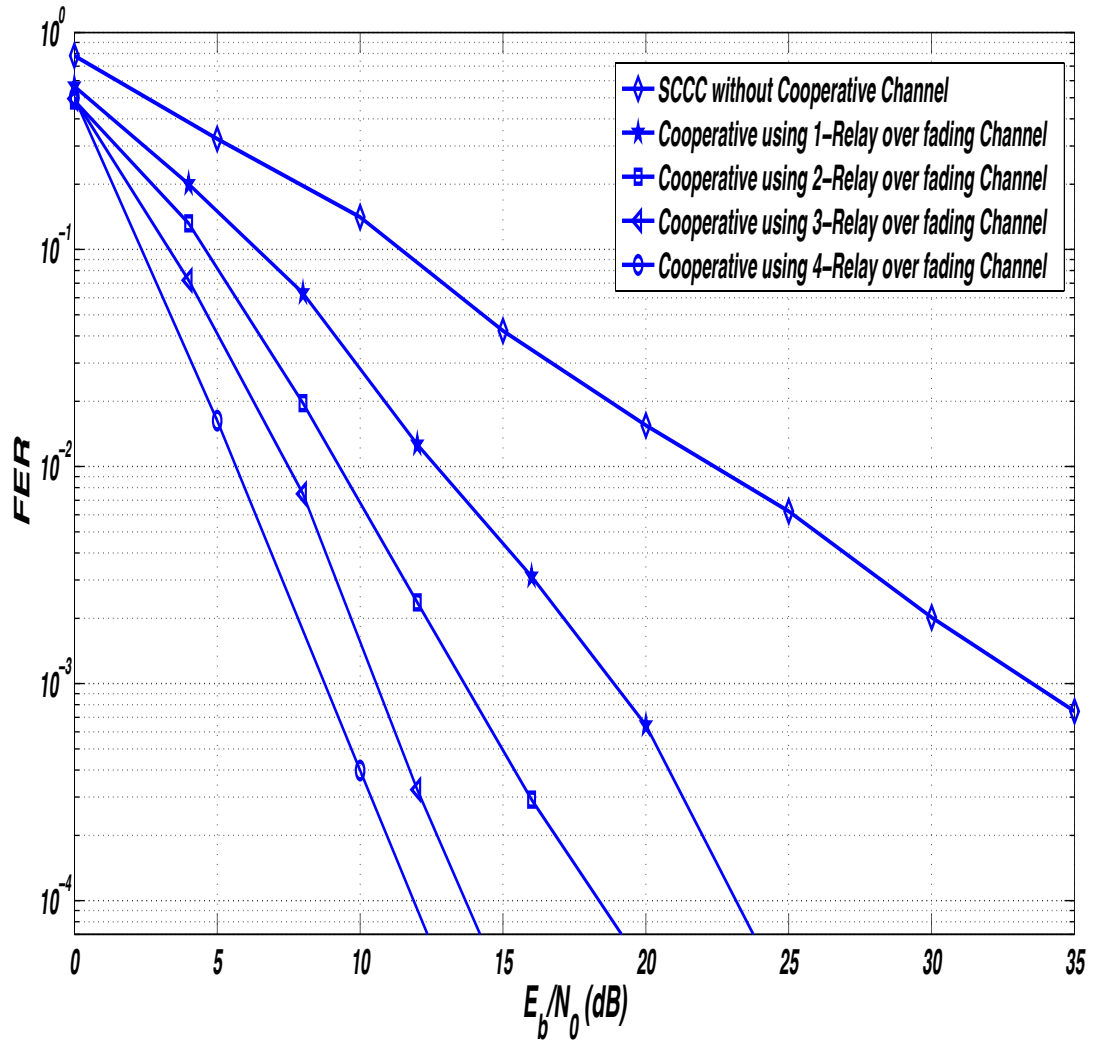

Figure 28 SCCC in cooperative communication system using IDM method, *Soft Decoding with Full Encoding in Relays*, over fading channel; Frame Error Rate (FER) simulation results are displayed

4.7 CPC in Cooperative Channel Coding

In Figure 29, we compare two methods with three cases, SCCC, CPC-4 rows, CPC-8 rows and all these cases are used in relay based systems and non-cooperative systems. Each case has different number of relay nodes. It is seen from simulation results that there is a significant improvement with increasing the number of relay nodes. It is obvious from Fig. 29 that the systems that have equal number of relay nodes show similar performance. The advantage of CPC based systems over the classical ones is the reduced latency due to parallel processing utility. In these simulations, *Classical Method* (Full Encoder in the Relays) is used in the relay

nodes. In the destination D, Maximum Ratio Combining (MRC) method is used to combine the signals. It is clear that the BER of the cooperative communication systems are much better with increasing number of the relay nodes than the direct transmission (without cooperation relay nodes). The noisy channels that are used to transmit the frames are Additive White Gaussian Noise (AWGN) channels.

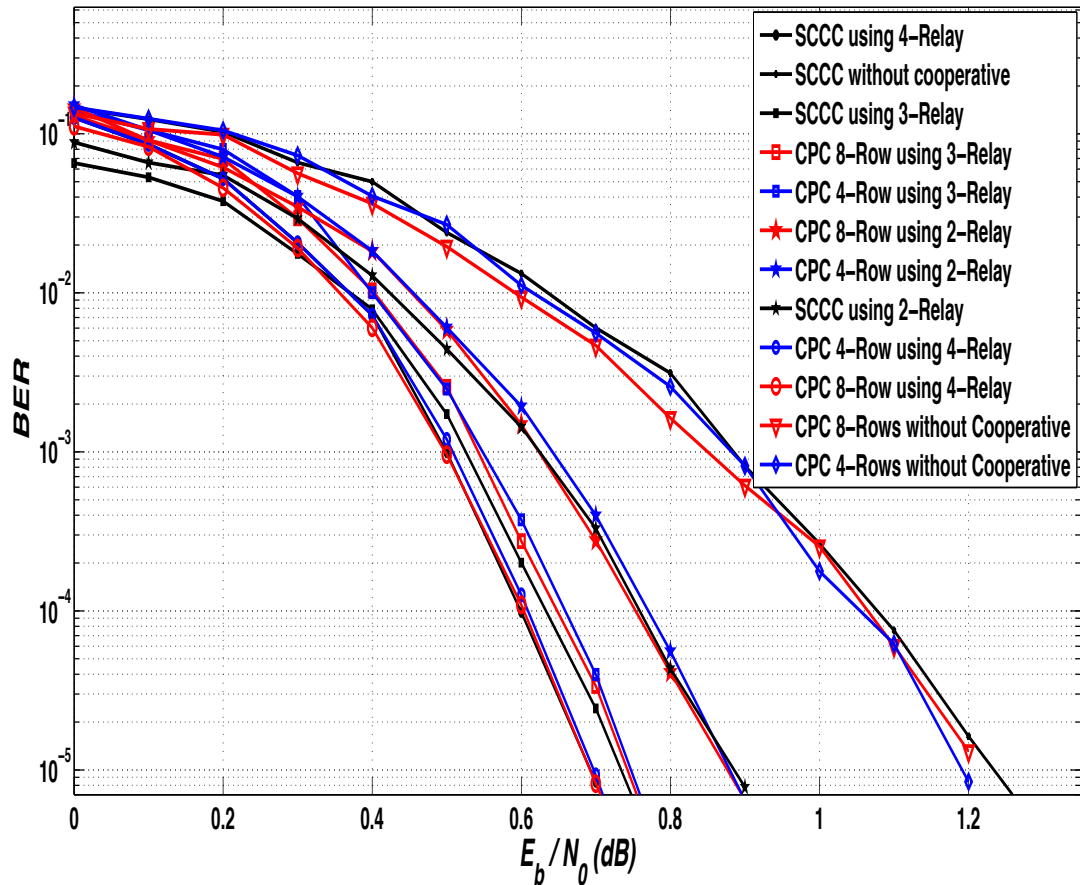

Figure 29 Bit Error Rate (BER) simulation results for SCCC, CPC-4 rows and CPC-8 rows. MRC is used at the destination

CHAPTER 5

CONCLUSION AND FUTURE WORK

5.1 Conclusion

In this thesis, we have studied the cooperative communication systems employing SCCCs and CPCS. We used more than one methods for decoding and more than one strategies in the relay nodes R_k and in the destination D. We proposed these strategies to reduce the latency and/or increase the system performance. We considered different scenarios where different number of relay nodes is considered. It is seen from simulation results that increasing the number of relay nodes can effectively mitigate error propagation and significantly improve the system performance. Cooperative coding is still a good substitute for the conventional coded schemes, especially in noisy fading channels where there are abundant dedicated relays.

The major drawback of cooperative communication is the large processing time in the relay nodes which is a serious problem especially for real time communication systems.

In this thesis study we focused on three different scenarios. One is based on the idea of decode-encode and forward. We call this approach as the classical design (“*Soft Decoding with half hard Decision Encoding in Relays*” and “*Soft Decoding with Full hard Decision Encoding in Relays*”). Since full encoding is performed at the relays this increases the decoding latency at the destination. To reduce the latency at the destination we considered partial encoding cases at the relays. In one of these partial encoding schemes decoded signal is only convolutionally encoded and transmitted.

In second partial encoding method, decoded signal is modulated and transmitted. It is seen from the simulation results that partial encoding shows better performance than full encoding schemes. This is due to the efficient use of power for transmission.

In addition a method which we call as Individual Decoding Method (IDM) is proposed to combine the signals at the destination D to increase the system performance. This method shows a significant improvement in BER for Additive White Gaussian Noise (AWGN) channels and fading channels.

For non-cooperative communication systems (without dedicated relay nodes) the latency is certainly less, but the performance is much worse. Besides, increasing the number of relay nodes increases the performance. However, use of many relay nodes brings some extra drawbacks such as hardware complexity, more processing at the destination and increment in latency. Having more cooperating relay nodes would lead to higher diversity gain, and also the probability of reliable decoding increases. The use of CPCs in cooperative communication have the benefit of low decoding latency due to parallel processing utility and easiness of the implementation when compared to its counterparts such as the SCCC in cooperative communications.

5.2 Future Work

An intelligent relay network can be considered in which relays may have the knowledge of channel states. And those relays that have good channel states among them can be divided into different groups and each group selects a head-relay at where group signals are combined and re-transmitted. In this way instead of sending weak individual signals from the relays one strong signal is sent from a group of relays. At the destination signals coming from the relay groups are classified according to their strangeness and the best ones are combined using the MRC.

REFERENCES

1. **Telatar I. E., (1999)**, “*Capacity of Multi-Antenna Gaussian Channels*”, European Transactions on Telecommunications, vol. 10, no. 6, pp. 585–595.
2. **Foschini G. J., Gans M. J., (1998)**, “*On Limits of Wireless Communications in a Fading Environment When Using Multiple Antennas*”, Wireless Personal Communication, vol. 6, no. 3, pp. 311–335.
3. **Alamouti S. M., (1998)**, “*A Simple Transmit Diversity Technique for Wireless Communications*”, IEEE Journal on Selected Areas in Communications, vol. 16, no. 8, pp. 1451–1458.
4. **Tarokh V., Jafarkhani H., Calderbank A. R., (1999)**, “*Space–Time Block Coding for Wireless Communications: Performance Results*”, IEEE Journal on Selected Areas in Communications, vol. 17, no. 3, pp. 451–460.
5. **Tarokh V., (1999)**, “*Space–Time Block Codes from Orthogonal Designs*”, IEEE Transactions on Information Theory, vol. 45, no. 5, pp. 1456–1467.
6. **Tarokh V., Seshadri N., Calderbank A. R., (1998)**, “*Space–Time Codes for High Data Rate Wireless Communication: Performance Criterion and Code Construction*”, IEEE Transactions on Information Theory, vol. 44, no. 2, pp. 744–765.
7. **Loyka S., Kouki A., (2002)**, “*On MIMO Channel Capacity, Correlations, and Keyholes: Analysis of Degenerate Channels*”, IEEE Transactions on Communications, vol. 50, no. 12, pp. 1886–1888.
8. **Shin H., Lee J. H., (2003)**, “*Capacity of Multiple-Antenna Fading Channels: Spatial Fading Correlation, Double Scattering, and Keyhole*”, IEEE Transactions on Information Theory, vol. 49, no. 10, pp. 2636–2647.

9. **Shiu D. S., Foschini G. J., Gans M. J., Kahn J. M., (2000)**, “*Fading Correlation and its Effect on The Capacity of Multi Element Antenna Systems*”, IEEE Transactions on Communications, vol. 48, no. 3, pp. 502–513.
10. **Chuah C. N., Tse D. N. C., Kahn J. M., Valenzuela R. A., (2002)**, “*Capacity Scaling in MIMO Wireless Systems Under Correlated Fading*”, IEEE Transactions on Information Theory, vol. 48, no. 3, pp. 637–650.
11. **Soldani D., Dixit S., (2008)**, “*Wireless Relays for Broadband Access*”, IEEE Communications Magazine, vol. 46, no. 3, pp. 58–66.
12. **Van der Meulen E. C., (1971)**, “*Three-Terminal Communication Channels*”, Advances in Applied Probability, vol. 3, pp. 120–154.
13. **Cover T. M., El Gamal A. A., (1979)**, “*Capacity Theorems for The Relay Channel*”, IEEE Transactions on Information Theory, vol. 25, no. 5, pp. 572–584.
14. **Schein B., Gallager R., (2000)**, “*The Gaussian Parallel Relay Network*”, IEEE International Symposium on Information Theory, Sorrento, pp. 22.
15. **Gupta P., Kumar P. R., (2000)**, “*The Capacity of Wireless Networks*”, IEEE Transactions on Information Theory, vol. 46, no. 2, pp. 388–404.
16. **Xie L. L., Kumar P. R., (2004)**, “*A Network Information Theory for Wireless Communication: Scaling Laws and Optimal Operation*”, IEEE Transactions on Information Theory, vol. 50, no. 5, pp. 748–767.
17. **Laneman J. N., Wornell G. W., (2003)**, “*Distributed Space–Time-Coded Protocols for Exploiting Cooperative Diversity in Wireless Networks*”, IEEE Transactions on Information Theory, vol. 49, no. 10, pp. 2415–2425.
18. **Laneman J. N., Tse D. N. C., Wornell G. W., (2004)**, “*Cooperative Diversity in Wireless Networks: Efficient Protocols and Outage Behavior*”, IEEE Transactions on Information Theory, vol. 50, no. 12, pp. 3062–3080.
19. **Sendonaris A., Erkip E., Aazhang B., (2003)**, “*User Cooperation Diversity—Part I: System Description*”, IEEE Transactions on Communications, vol. 51, no. 11, pp. 1927–1938.

20. **Sendonaris A., (2003)**, “*User Cooperation Diversity—Part II: Implementation Aspects and Performance Analysis*”, IEEE Transactions on Communications, vol. 51, no. 11, pp. 1939 – 1948.
21. **Nabar R. U., Bolcskei H., Kneubuhler F. W., (2004)**, “*Fading Relay Channels: Performance Limits and Space–Time Signal Design*”, IEEE Journal on Selected Areas in Communications, vol. 22, no. 6, pp. 1099–1109.
22. **Host-Madsen A., (2006)**, “*Capacity Bounds for Cooperative Diversity*”, IEEE Transactions on Information Theory, vol. 52, no. 4, pp. 1522–1544.
23. **Wang B., Zhang J., Host-Madsen A., (2005)**, “*On The Capacity of MIMO Relay Channels*”, IEEE Transactions on Information Theory, vol. 51, no. 1, pp. 29–43.
24. **Yang Y., Hu H., Xu J., (2009)**, “*Relay Technologies for WiMAX and LTE Advanced Mobile Systems*”, IEEE Communications Magazine, vol. 47, no. 10, pp. 100–105.
25. **Bletsas A., Khisti A., Reed D. P., Lippman A., (2006)**, “*A Simple Cooperative Diversity Method Based on Network Path Selection*”, IEEE Journal on Selected Areas in Communications, vol. 24, no. 3, pp. 659–672.
26. **Hu J., Beaulieu N. C., (2007)**, “*Performance Analysis of Decode-and-Forward Relaying with Selection Combining*”, IEEE Communication Letters, vol. 11, no. 6, pp. 489–491.
27. **Wang T., Cano A., Giannakis G. B., Laneman J. N., (2007)**, “*High Performance Cooperative Demodulation with Decode-and-Forward Relays*”, IEEE Transactions on Communications, vol. 55, no. 7, pp. 1427–1438.
28. **Yi Z., Kim I. M., (2008)**, “*Diversity Order Analysis of The Decode-and-Forward Cooperative Networks with Relay Selection*”, IEEE Transactions on Wireless Communication, vol. 7, no. 5, pp. 1792–1799.
29. **Duong T. Q., Bao V. N. Q., (2008)**, “*Performance Analysis of Selection Decode-and-Forward Relay Networks*”, IET Electronics Letters, vol. 44, no. 20, pp. 1206–1207.

30. **Duong T. Q., Bao V. N. Q., Zepernick H. J., (2009)**, “*On The Performance of Selection Decode and Forward Relay Networks Over Nakagami-m Fading Channels*”, IEEE Communications Letters, vol. 13, no. 3, pp. 172–174.
31. **Azarian K., El Gamal H., Schniter P., (2005)**, “*On The Achievable Diversity–Multiplexing Tradeoff in Half-Duplex Cooperative Channels*”, IEEE Transactions on Information Theory, vol. 51, no. 12, pp. 4152–4172.
32. **Murugan A., Azarian K., El Gamal H., (2007)**, “*Cooperative Lattice Coding and Decoding in Half-Duplex Channels*”, IEEE Journal on Selected Areas in Communications, vol. 25, no. 2, pp. 268–279.
33. **Bolcskei H., Nabar R. U., Oyman O., Paulraj A. J., (2006)**, “*Capacity Scaling Laws in MIMO Relay Networks*”, IEEE Transactions on Wireless Communications, vol. 5, no. 6, pp. 1433–1444.
34. **Duong T. Q., Zepernick H. J., (2009)**, “*On The Performance Gain of Hybrid Decode-Amplify-Forward Cooperative Communications*”, EURASIP Journal on Wireless Communications and Networking, vol. 2009, article ID 479463, pp.1-10.
35. **Kramer G., Gastpar M., P. Gupta, (2005)**, “*Cooperative Strategies and Capacity Theorems for Relay Networks*”, IEEE Transactions on Information Theory, vol. 51, no. 9, pp. 3037–3063.
36. **Chakrabarti A., de Baynast A., Sabharwal A., Aazhang B., (2006)**, “*Halfduplex Estimate-and-Forward Relaying: Bounds and Code Design*”, IEEE International Symposium on Information Theory, Seattle, Washington, pp. 1239–1241.
37. **Gomadam K. S., Jafar S. A., (2006)**, “*On The Capacity of Memoryless Relay Networks*”, IEEE International Communications, pp. 1580–1585.
38. **Hunter T. E., Nosratinia A., (2006)**, “*Diversity Through Coded Cooperation*”, IEEE Transactions Wireless Communications, vol. 5, no. 2, pp. 283–289.
39. **Hunter T. E., Sanayei S., Nosratinia A., (2006)**, “*Outage Analysis of Coded Cooperation*”, IEEE Transactions on Information Theory, vol. 52, no. 2, pp. 375–391.

40. **Nosratinia A., Hunter T. E., Hedayat A., (2004)**, “*Cooperative Communication in Wireless Networks*”, IEEE Communications Magazine, pp. 74–80.
41. **Michalopoulos D. S., Karagiannidis G. K., (2007)**, “*Distributed Switch and Stay Combining (DSSC) with a Single Decode and Forward Relay*”, IEEE Communications Letters, vol. 11, no. 5, pp. 408–410.
42. **Michalopoulos D. S., Karagiannidis G. K., (2008)**, “*Two-Relay Distributed Switch and Stay Combining (DSSC)*”, IEEE Transactions on Communications, vol. 56, no. 11, pp. 1790–1794.
43. **Bao V. N. Q., Kong H. Y., (2009)**, “*Distributed Switch and Stay Combining for Selection Relay Networks*”, IEEE Communications Letters, vol. 13, no. 12, pp. 914–916.
44. **Zhao Y., Adve R., Lim T. J., (2006)**, “*Symbol Error Rate of Selection Amplify-and-Forward Relay Systems*”, IEEE Communications Letters, vol. 10, no. 11, pp. 757–759.
45. **Tsiftsis T. A., Karagiannidis G. K., Mathiopoulos P. T., Kotsopoulos S. A., (2006)**, “*Nonregenerative Dual-Hop Cooperative Links with Selection Diversity*”, EURASIP Journal on Wireless Communications and Networking, vol. 2006, article ID 17862, pp. 1-8.
46. **Krikidis I., Thompson J., McLaughlin S., Goertz N., (2008)**, “*Amplify-and-Forward with Partial Relay Selection*”, IEEE Communications Letters, vol. 12, no. 4, pp. 235–237.
47. **Da Costa D. B., Aissa S., (2009)**, “*Capacity Analysis of Cooperative Systems with Relay Selection in Nakagami-m Fading*”, IEEE Communications Letters, vol. 13, no. 9, pp. 637–639.
48. **Ding H., Ge J., Jiang Z., (2010)**, “*Asymptotic Performance Analysis of Amplify-and-Forward with Partial Relay Selection in Rician Fading*”, IET Electronics Letters, vol. 46, no. 3, pp. 248–250.
49. **Suraweera H. A., Michalopoulos D. S., Karagiannidis G. K., (2009)**, “*Semiblind Amplify-and-Forward with Partial Relay Selection*”, IET Electronics Letters, vol. 45, no. 6, pp. 317–319.

50. **Rui X., (2010)**, “*Performance of Selective Decode-and-Forward Relay Networks with Partial Channel Information*”, ETRI Journal, vol. 32, no. 1, pp. 139–141.
51. **Suraweera H. A., Soysa M., Tellambura C., Garg H. K., (2010)**, “*Performance Analysis of Partial Relay Selection with Feedback Delay*”, IEEE Signal Processor Letters.
52. **Da Costa D. B., Aissa S., (2009)**, “*End-to-End Performance of Dual-Hop Semiblind Relaying Systems with Partial Relay Selection*”, IEEE Transactions Wireless Communications, vol. 8, no. 8, pp. 4306–4315.
53. **Rui X., (2010)**, “*Decode-and-Forward with Partial Relay Selection*”, Willey International Journal of Communication Systems.
54. **Ribeiro A., Cai X., Giannakis G. B., (2005)**, “*Symbol Error Probability for General Cooperative Links*”, IEEE Transactions Wireless Communications, vol. 4, no. 3, pp. 1264–1273.
55. **Chen D., Laneman J. N., (2006)**, “*Modulation and Demodulation for Cooperative Diversity in Wireless Systems*”, IEEE Transactions Wireless Communication, vol. 5, no. 7, pp. 1785–1794, Jul. 2006.
56. **Rankov B., Wittneben A., (2007)**, “*Spectral Efficient Protocols for Half-Duplex Fading Relay Channels*”, IEEE Journal on Selected Areas in Communications, vol. 25, no. 2, pp. 379–389.
57. **Popovski P., Yomo H., (2007)**, “*Wireless Network Coding by Amplify-and-Forward for Bi-Directional Traffic Flows*”, IEEE Communications Letters, vol. 11, no. 1, pp. 16–18.
58. **Duong T. Q., Hoang L.-N., Bao V. N. Q., (2009)**, “*On The Performance of Two-Way Amplify-and-Forward Relay Networks*”, IEICE Transactions on Communications, vol. E92-B, no. 12, pp. 3957–3959.
59. **Oechtering T. J., Jorswieck E. A., Wyrembelski R. F., Boche H., (2009)**, “*On The Optimal Transmit Strategy for The MIMO Bidirectional Broadcast Channel*”, IEEE Transactions Communications, vol. 57, no. 12, pp. 3817–3826.

60. **Louie R. H. Y., Li Y., Vucetic B., (2010)**, “*Practical Physical Layer Network Coding for Two-Way Relay Channels: Performance Analysis and Comparison*”, IEEE Transactions Wireless Communications, vol. 9, no. 2, pp. 764–777.
61. **Boyer J., Falconer D. D., Yanikomeroglu H., (2004)**, “*Multihop Diversity in Wireless Relaying Channels*”, IEEE Transactions Communications, vol. 52, no. 10, pp. 1820–1830.
62. **Hasna M. O., Alouini M. S.,(2003)**, “*End-to-End Performance of Transmission Systems with Relays Over Rayleigh-Fading Channels*”, IEEE Transactions Wireless Communications, vol. 2, no. 6, pp. 1126–1131.
63. **Dohler M., Gkelias A., Aghvami H., (2004)**, “*A Resource Allocation Strategy for Distributed MIMO Multi-Hop Communication Systems*”, IEEE Communications Letters, vol. 8, no. 2, pp. 99–101.
64. **Hasna M. O., Alouini M. S., (2004)**, “*Harmonic Mean and End-to-End Performance of Transmission Systems with Relays*”, IEEE Transactions Communications, vol. 52, no. 1, pp. 130–135.
65. **Karagiannidis G. K., Tsiftsis T. A., Mallik R. K., (2006)**, “*Bounds for Multihop Relayed Communications in Nakagami-m Fading*”, IEEE Transactions Communications, vol. 54, no. 1, pp. 18–22.
66. **Karagiannidis G. K., Tsiftsis T. A., Mallik R. K., Sagias N. C., Kotsopoulos S. A., (2005)**, “*Closed-Form Bounds for Multihop Relayed Communications in Nakagami*”, IEEE International Communications, pp. 2362–2366.
67. **Oyman O., J. Laneman N., Sandhu S., (2007)**, “*Multihop Relaying for Broadband Wireless Mesh Networks: From Theory to Practice*”, IEEE Communications Magazine, vol. 45, no. 11, pp. 116–122.
68. **Burr A., (2001)**, “*The Ultimate Error Control Codes*”, Turbo-codes: Electronics & Communication Engineering Journal, 2001. 13(4): pp. 155-165.
69. **Valenti M.C., Sun J., (2004)**, “*Handbook of RF and Wireless Technologies*”, Turbo Codes, Edited by Dowla F., 2004: Newnes Press, Pp. 375 - 399.

70. **Sadjadpour H.R., Sloane N.J.A., Nebe G., (2001)**, “*Interleaver Design for Turbo Codes*”, IEEE Journal on Selected Areas in Communications, pp. 831-837.

71. **Sklar B., (2001)**, “*Fundamentals and Applications*”, Digital Communications: Second Edition Fundamentals of Turbo Codes: Prentice Hall.

72. **Heegard C., Wicker S.B., (1999)**, “*Turbo Coding*”, First Edition, Boston: Kluwer Academic Publisher.

73. **William E. R., (2011)**, “*Concatenated Convolutional Codes and Iterative Decoding*”, University Arizona.

APPENDICES A

CURRICULUM VITAE

PERSONAL INFORMATION

Surname, Name: HADI, Ali Sameer

Date and Place of Birth: 21 October 1989, Kut / Iraq

Country of Origin: Iraq

Marital Status: Engaged

Phone 1: +90 536 071 44 75

Phone 2: +964 770 250 51 20

Email 1: Ali.alsamraai@gmail.com

Email 2: Ali_Alsamraai@hotmail.com



EDUCATION

Degree	Institution and the location	Year of Graduation
<i>M.Sc.</i>	<i>Çankaya University, Electronic and Communication Engineering / Ankara, Turkey</i>	<i>2014</i>
<i>B.Sc.</i>	<i>Al-Mansour University College, Computer Communication Engineering / Baghdad, Iraq</i>	<i>2012</i>
<i>High School</i>	<i>Abd-El-Kader High School / Damascus, Syria</i>	<i>2008</i>

WORK EXPERIENCE

Year	Place	Enrolment
<i>2014 November - December</i>	The American institute for business & development (AIBD): Diploma in Business Administration	<i>Training</i>
<i>2014 November</i>	The American institute for business & development (AIBD): <i>Training of Trainers (TOT)</i>	<i>Training</i>
<i>2012 September - October - November- December</i>	<i>Orbital Telecommunication Company</i>	<i>Engineering</i>
<i>2012</i>	<i>CCNA Exploration: Routing Protocols and Concepts held by CiSCO</i>	<i>Training</i>
<i>2008 - 2012</i>	<i>EarthLink Company for Internet service</i>	<i>Technical</i>
<i>2011</i>	<i>CCNA Exploration: Network Fundamentals held by CiSCO</i>	<i>Training</i>
<i>2006 - 2008</i>	<i>Al-Samraai Company for computer maintenance</i>	<i>Technical</i>

LANGUAGES

Arabic: Native

English: Advanced

Turkish: Pre-Intermediate

PUBLICATIONS

- ❖ **Hadi A., Gazi O., 15-16 May (2014),** “*Convolution Product Code (CPC) in Cooperative Channel Coding*”, Progress in Communication Channel Code, Conf. 7. Mühendislik ve Teknoloji Sempozyumu (MTS7), *Çankaya Univ., Ankara, Turkey.*

HOBBIES

Running, Football, Tennis, Cycling, Chess, Puzzle